

## Off-Line Digital Power Controller for LED Driver with High Power Factor and Low-Ripple Current

### 1.0 Features

- All-in-one non-dimmable low-cost off-line LED driver (isolated and non-isolated applications)
- Supports universal input voltage range ( $90V_{AC}$  to  $277V_{AC}$ ) and output power up to 45W
- High power factor (PF) with low current-ripple control technology
- User-configurable power factor setting ( $> 0.7$  to  $> 0.95$ )
- Able to achieve low THD ( $< 20\%$ )
- User-configurable internal or external over-temperature protection (OTP) with temperature-current derating
- Tight LED current regulation ( $\pm 5\%$ ) across line and load, and within primary inductance tolerance ( $\pm 20\%$ )
- Isolated design without opto-coupler
- Stabilized LED current-ripple control without visible shimmer or flicker
- Active start-up scheme enables fastest possible start-up
- 72kHz nominal PWM switching frequency with quasi-resonant operation
- EZ-EMI<sup>®</sup> design enhances manufacturability
- Built-in single-point fault protection features: LED open-/short-circuit protection and over-current protection
- No audible noise over entire operating range



### 2.0 Description

The iW3622 is a high performance, single-stage AC/DC power controller for LED luminaires with power factor (PF) correction. The device uses digital control technology to build unique control in PWM flyback/buck-boost power supplies to achieve high power factor while minimizing the LED current ripple. This distinctive control approach enables the capability for users to make trade-offs between the PF and LED current ripple in a single-stage design. It can achieve excellent LED current regulation over line and load variation, without the need for secondary feedback circuit. The built-in temperature sensor along with control logic can automatically adjust output current in real-time without visible flicker during the process. Alternatively, the external NTC thermistor is placed close to the hot spots in a design to provide thermal protection in the similar pattern by derating LED current. The iW3622 operates in quasi-resonant mode to provide high efficiency along with a number of key built-in protection features while minimizing the external component count, simplifying EMI design, and lowering the total bill of material cost. It also eliminates the need for loop compensation components while maintaining stability over all operating conditions.

Dialog's innovative proprietary technology maximizes the iW3622 performance in a tiny SOT-23 package. The iW3622 offers two multi-function pins allowing users to configure PF and LED current derating as required with no cost or size impact, thereby providing design flexibility. In addition to providing the temperature sensing via an NTC resistor, the MULTI pin also enables active start-up scheme to achieve the shortest possible start-up time without sacrificing active efficiency.

### 3.0 Applications

- Solid-state LED lighting
- LED lighting ballast

## Off-Line Digital Power Controller for LED Driver with High Power Factor and Low-Ripple Current

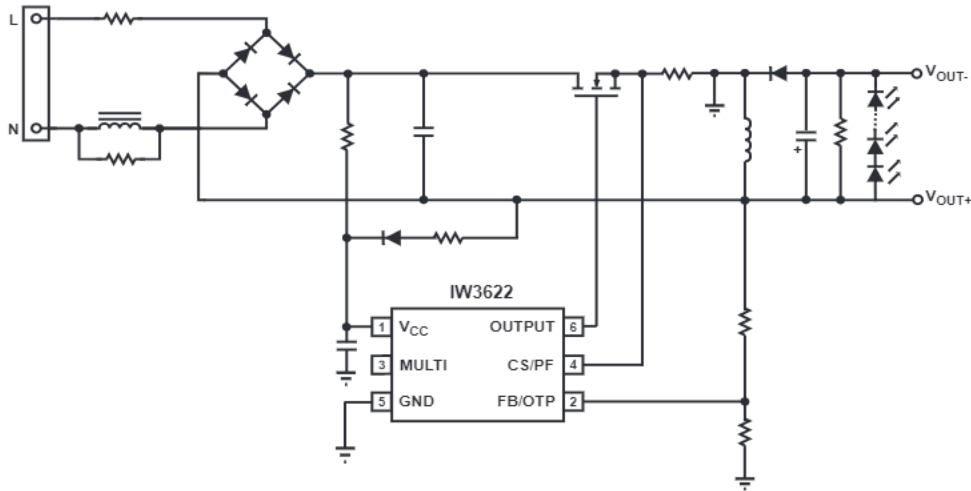

Figure 3.1: iW3622 Typical Application Circuit (Non-Isolated Buck-Boost Application)

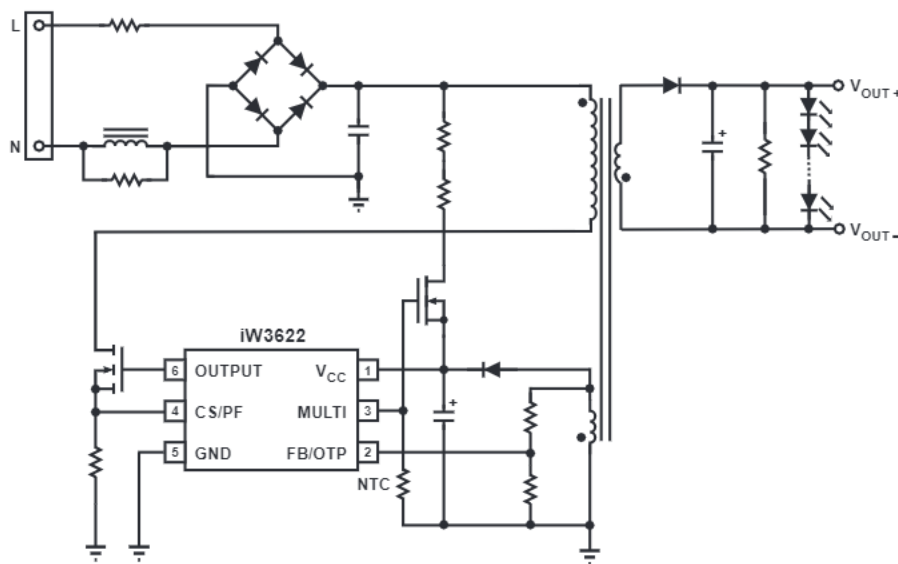

Figure 3.2: iW3622 Typical Application Circuit (Isolated Flyback Application Using Active Start-up Device)

## Off-Line Digital Power Controller for LED Driver with High Power Factor and Low-Ripple Current

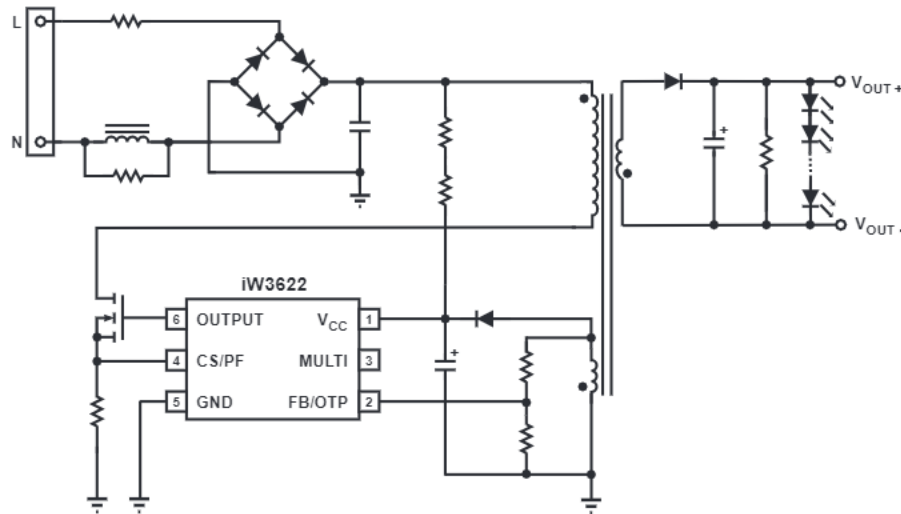

Figure 3.3: iW3622 Typical Application Circuit (Isolated Flyback Application without Using Active Start-up Device)

## Off-Line Digital Power Controller for LED Driver with High Power Factor and Low-Ripple Current

### 4.0 Pinout Description

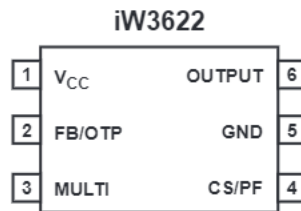

Figure 4.1: 6-Lead SOT-23 Package

Pin #	Name	Type	Pin Description
1	V <sub>CC</sub>	Power Input	Power supply for control logic and MOSFET drive.
2	FB/OTP	Analog Input	Multi-function pin. Used for internal or external OTP current derating configuration at the beginning of start-up and to provide output voltage sense for primary regulation during normal operation.
3	MULTI	Output	Multi-function pin. Used to control active start-up device and for external temperature sensing via an NTC resistor.
4	CS/PF	Analog Input	Multi-function pin. Used for PF configuration at the beginning of start-up and to provide primary current sense for cycle-by-cycle peak current control and limit during normal operation.
5	GND	Ground	Ground.
6	OUTPUT	Output	Gate drive for external MOSFET switch.

### 5.0 Absolute Maximum Ratings

Absolute maximum ratings are the parameter values or ranges which can cause permanent damage if exceeded.

Parameter	Symbol	Value	Units
DC supply voltage range (pin 1, I <sub>CC</sub> = 20mA max)	V <sub>CC</sub>	-0.3 to 18.0	V
Continuous DC supply current at V <sub>CC</sub> pin (V <sub>CC</sub> = 15V)	I <sub>CC</sub>	20	mA
MULTI (pin 3)		-0.3 to 18.0	V
OUTPUT (pin 6)		-0.3 to 18.0	V
FB/OTP input (pin 2, I <sub>FB/OTP</sub> ≤ 10mA)		-0.7 to 4.0	V
CS/PF input (pin 4)		-0.3 to 4.0	V
Maximum junction temperature	T <sub>JMAX</sub>	150	°C
Operating junction temperature	T <sub>JOPT</sub>	-40 to 150	°C
Storage temperature	T <sub>STG</sub>	-65 to 150	°C
Thermal resistance junction-to-ambient	θ <sub>JA</sub>	190	°C/W
ESD rating per JEDEC JESD22-A114		±2,000	V
Latch-up test per JESD78A		±100	mA

## Off-Line Digital Power Controller for LED Driver with High Power Factor and Low-Ripple Current

### 6.0 Physical Dimensions

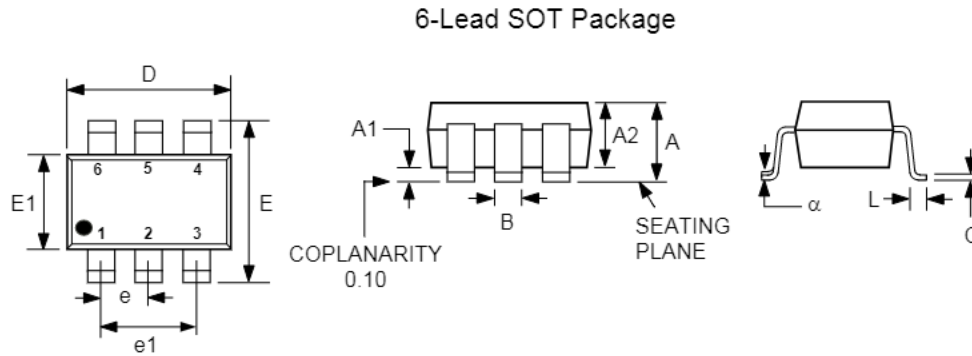

Symbol	Millimeters	
	MIN	MAX
A	-	1.45
A1	0.00	0.15
A2	0.90	1.30
B	0.30	0.50
C	0.08	0.22
D	2.90 BSC	
E	2.80 BSC	
E1	1.60 BSC	
e	0.95 BSC	
e1	1.90 BSC	
L	0.30	0.60
$\alpha$	0°	8°

SOT23-6 devices are marked with a 4-digit code. Orientation of Pin 1 is shown below:

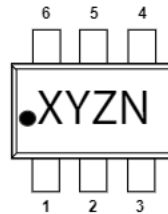

Compliant to JEDEC Standard MO-178AB

Controlling dimensions are in millimeters

This package is RoHS compliant and Halide free.

Soldering Temperature Resistance:

- [a] Package is IPC/JEDEC Std 020D Moisture Sensitivity Level 1
- [b] Package exceeds JEDEC Std No. 22-A111 for Solder Immersion Resistance; packages can withstand 10 s immersion < 260°C

Dimension D does not include mold flash, protrusions or gate burrs. Mold flash, protrusions or gate burrs shall not exceed 0.25 mm per side.

The package top may be smaller than the package bottom. Dimensions D and E1 are determined at the outermost extremes of the plastic body exclusive of mold flash, tie bar burrs and interlead flash, but including any mismatch between top and bottom of the plastic body.

### 7.0 Ordering Information

Part Number	Options	Package	Description
iW3622-00	Internal OTP derating, 72kHz switching frequency	SOT-23	Tape & Reel <sup>1</sup>
iW3622-01	NTC OTP derating, 72kHz switching frequency	SOT-23	Tape & Reel <sup>1</sup>

Note 1: Tape & Reel packing quantity is 3,000/reel. Minimum ordering quantity is 3,000.

## Off-Line Digital Power Controller for LED Driver with High Power Factor and Low-Ripple Current

### Disclaimer

Information in this document is believed to be accurate and reliable. However, Dialog Semiconductor does not give any representations or warranties, expressed or implied, as to the accuracy or completeness of such information. Dialog Semiconductor furthermore takes no responsibility whatsoever for the content in this document if provided by any information source outside of Dialog Semiconductor.

Dialog Semiconductor reserves the right to change without notice the information published in this document, including without limitation the specification and the design of the related semiconductor products, software and applications.

Applications, software, and semiconductor products described in this document are for illustrative purposes only. Dialog Semiconductor makes no representation or warranty that such applications, software and semiconductor products will be suitable for the specified use without further testing or modification. Unless otherwise agreed in writing, such testing or modification is the sole responsibility of the customer and Dialog Semiconductor excludes all liability in this respect.

Customer notes that nothing in this document may be construed as a license for customer to use the Dialog Semiconductor products, software and applications referred to in this document. Such license must be separately sought by customer with Dialog Semiconductor.

All use of Dialog Semiconductor products, software and applications referred to in this document are subject to Dialog Semiconductor's [Standard Terms and Conditions of Sale](#), unless otherwise stated.

© Dialog Semiconductor (UK) Ltd. All rights reserved.

### RoHS compliance

Dialog Semiconductor complies to European Directive 2001/95/EC and from 2 January 2013 onwards to European Directive 2011/65/EU concerning Restriction of Hazardous Substances (RoHS/RoHS2).

Dialog Semiconductor's statement on RoHS can be found on the customer portal <https://support.diasemi.com/>. RoHS certificates from our suppliers are available on request.

## Contacting Dialog Semiconductor

### United Kingdom

Dialog Semiconductor (UK) Ltd  
Phone: +44 1793 757700

### Germany

Dialog Semiconductor GmbH  
Phone: +49 7021 805-0

### The Netherlands

Dialog Semiconductor B.V.  
Phone: +31 73 640 88 22

### Email

[info\\_pcbg@diasemi.com](mailto:info_pcbg@diasemi.com)

### North America

Dialog Semiconductor Inc.  
Phone: +1 408 845 8500

### Japan

Dialog Semiconductor K. K.  
Phone: +81 3 5425 4567

### Taiwan

Dialog Semiconductor Taiwan  
Phone: +886 8178 6222

### Web site:

[www.dialog-semiconductor.com](http://www.dialog-semiconductor.com)

### Singapore

Dialog Semiconductor Singapore  
Phone: +65 64849929

### Hong Kong

Dialog Semiconductor Hong Kong  
Phone: +852 2607 4271

### Korea

Dialog Semiconductor Korea  
Phone: +82 2 3469 8200

### China

Dialog Semiconductor  
(Shenzhen)  
Phone: +86 755 2981 3669

Dialog Semiconductor  
(Shanghai)  
Phone: +86 21 5178 2561