

IFO2225-830-FL

22" TFT Fanless Touch Panel Computer with Intel® Atom™ Processor N270

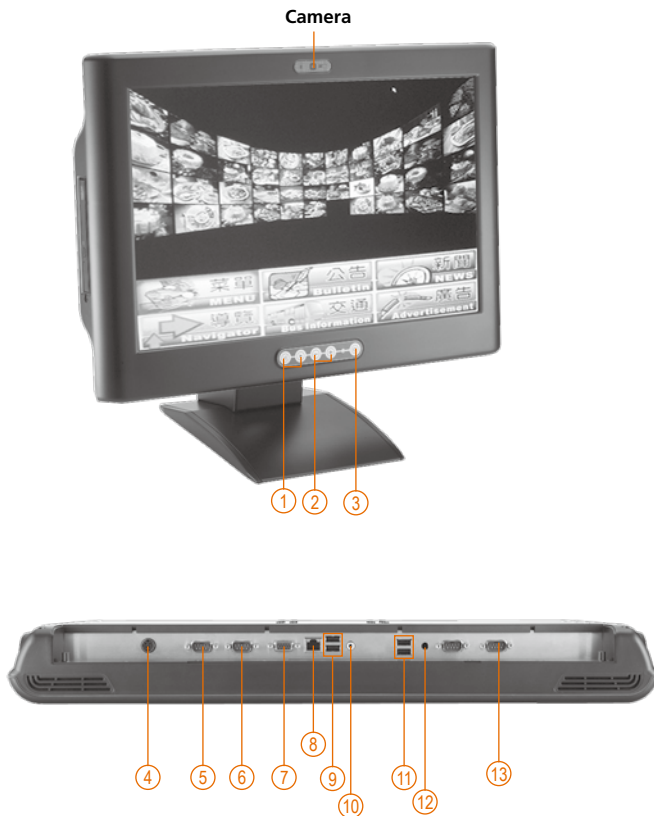

- | | | |
|------------------------------|----------------------|--------------------|
| 1. Brightness adjust buttons | 6. COM 2 (RS-232) | 11. USB 2.0 x2 |
| 2. Volume adjust buttons | 7. VGA | 12. COM 3 (RS-232) |
| 3. Power switch | 8. Ethernet | 13. COM 4 (RS-232) |
| 4. DC-in power connector | 9. USB 2.0 x 2 | |
| 5. COM 1 (RS-232/422/485) | 10. Audio (Line-out) | |

Features



Fanless Low Power DualView

- 22" (300 nits) WSXGA+ TFT LCD
- Intel® Atom™ processor N270 1.6 GHz
- Water/dust-proof design (front bezel: IP65, full enclosure: IPX1)
- Fanless and noiseless operation
- Optional 1.3 mega pixels camera
- Optional wireless (802.11 b/g) antenna

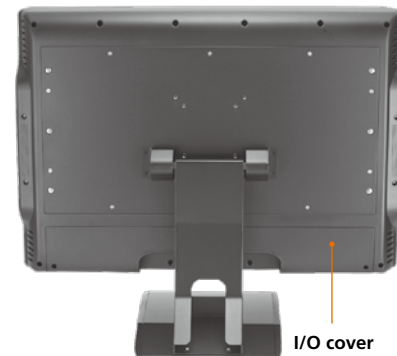

I/O cover

Introduction

The IFO2225-830-FL is a slim panel computer equipped with a 22-inch 300 nits WSXGA+ LCD display that supports a superior Intel® Atom™ processor N270. Powered by an Intel® 945GSE+ICH7M core logic chipset with maximum 256MB sharing graphics memory, this panel computer has enhanced graphics performance. The panel also supports DualView and multiple I/O options including 4 USB 2.0 and 4 RS-232 ports. The IFO2225-830-FL supports an antenna for 802.11b/g wireless connection. The Gigabit Ethernet ports provide an extremely high speed of Ethernet connectivity. It features low noise, low power consumption, high reliability and high performance. Its excellent industrial

design (ID) and user friendly interface design makes the IFO2225-830-FL a safe, reliable & user-friendly panel computer. Best suited for infotainment, media content display and DSA solutions.

Water/dust-proof design for entire system: IPX1

The IPX1-rated water/dust-proof housing protects the entire system from outside damage of water drip in a public place. Its unique design improves system stability and saves maintenance/re-installation time.

Specifications

Front Bezel	Plastic ABS (Black)	BIOS	AMI BIOS with SmartView and Customer CMOS Backup	
LCD Panel	Display Type	22" WSXGA+ TFT	Storage	Supports 1 x 2.5" SATA HDD
	Brightness (cd/m ²)	300 nits		1 x CompactFlash™
	Resolution	1680 x 1050	Optical Drive	1 x combo drive (optional)
	Viewing Angle (H/V)	178° / 178°	Watchdog	255 levels, 1-255 sec.
Main System	CPU	Intel® Atom™ processor N270 1.6 GHz	Timer	
	Chipset	Intel® 945GSE + ICH7M	Onboard	Integrated in Intel® 945GSE; max. memory shared 256 MB
	System Memory	1 x DDR2 SO-DIMM max. up to 2 GB	Graphics	

I/O Connectors	3 x RS-232 (COM 2/3/4) 1 x RS-232/422/485 (COM 1) 4 x USB 2.0 1 x Audio (Line-out) 1 x VGA 1 x 10/100/1000Mbps Ethernet
Expansion Interface	1 x Mini card slot
Camera	1 x 1.3 mega pixels camera
Touchscreen	Resistive type
Power Supply	24V _{oc} with AC-DC power adaptor
Dimensions	573.5 mm (22.58") (W) x 68.5 mm (2.69") (D) x 399 mm (15.71") (H)
Weight (net/gross)	8.22 kg (18.12 lb)/9.87 kg (21.76 lb)
Environment	Operating temperature: 0°C ~ +40°C (32°F ~ 104°F) Relative humidity: 10% ~ 95%, non-condensing Shock: 10G peak acceleration (11 sec. duration)
Certification	CE

Ordering Information

IF02225-830-FL-AC-CO	22" TFT high brightness fanless panel computer with Intel® Atom™ N270, resistive T/S, combo and camera
IF02225-830-FL-AC	22" TFT high brightness fanless panel computer with Intel® Atom™ N270, resistive T/S (w/o combo and camera)

* Specification and certifications are based on options and may vary.

Dimensions

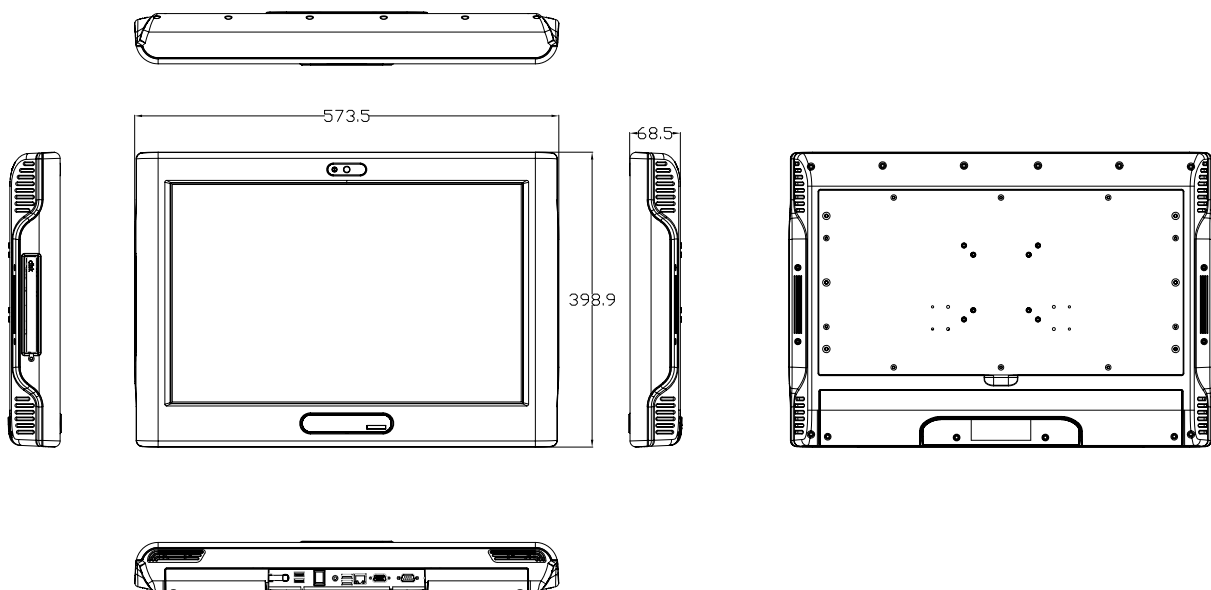

Optional Accessories

E202003330	VM-101 VESA ARM (clamp type)
E202003329	VM-105 VESA ARM (wall mount type)
E222175103	22" stand kit

Optional EOS Installation

Windows® XP Embedded

Optional OS Installation

Windows® XP
Windows® 7

Overview

Digital Signage Solutions

Healthcare & Medical Solutions
Medical Panel Computers

Healthcare & Medical Solutions
Medical Grade Monitors

Fanless & Heavy-duty Touch Panel Computers

Touch Panel Computers for Infotainment

Industrial Touch Panel Computers & Monitors
Industrial Touch Panel Computers

Industrial Touch Panel Computers & Monitors
Industrial Touch Panel Monitors

Open Frame Panel Computers

Accessories