

DETAILS

Product Number	FA10660_LXP-M
Family	Leila
Type	Assembly
Color	black
Diameter	21,6 mm
Height	14,7 mm
Style	round
Optic Material	PMMA
Holder Material	
Fastening	tape
Status	production ready
ROHS Compliant	Yes
Date Updated	10/04/2014



OPTICAL PROPERTIES

LED	Viewing	Light	Effi-	cd/lm	Connector
	Angle	Beam	ciency		
XP-E	22 deg	Medium	90 %	4.800	-
XP-G	26 deg	Medium	91 %	-	-
XP-E-HEW	21 deg	Medium	90 %	-	-
XT-E	24 deg	Medium	87 %	4.000	-
XP-G2	24 deg	Medium	87 %	4.300	-
XP-L HI	22 deg	Medium	86 %	4.400	-
LH351A(3535)	24 deg	Medium	90 %	4.700	-
Z5	18 deg	Medium	-	-	-

H G F E D C B A

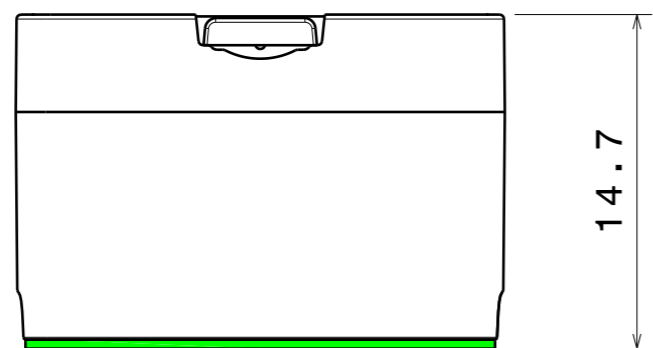

Front view
Scale: 3:1

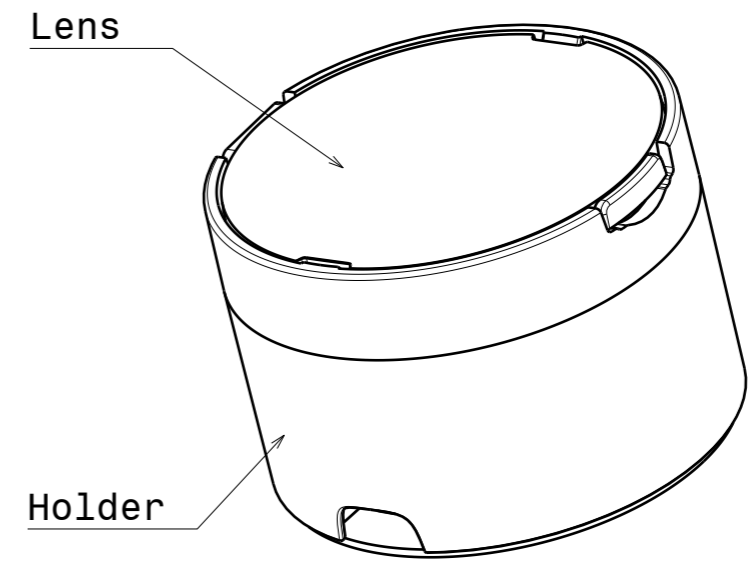

Isometric view
Scale: 3:1

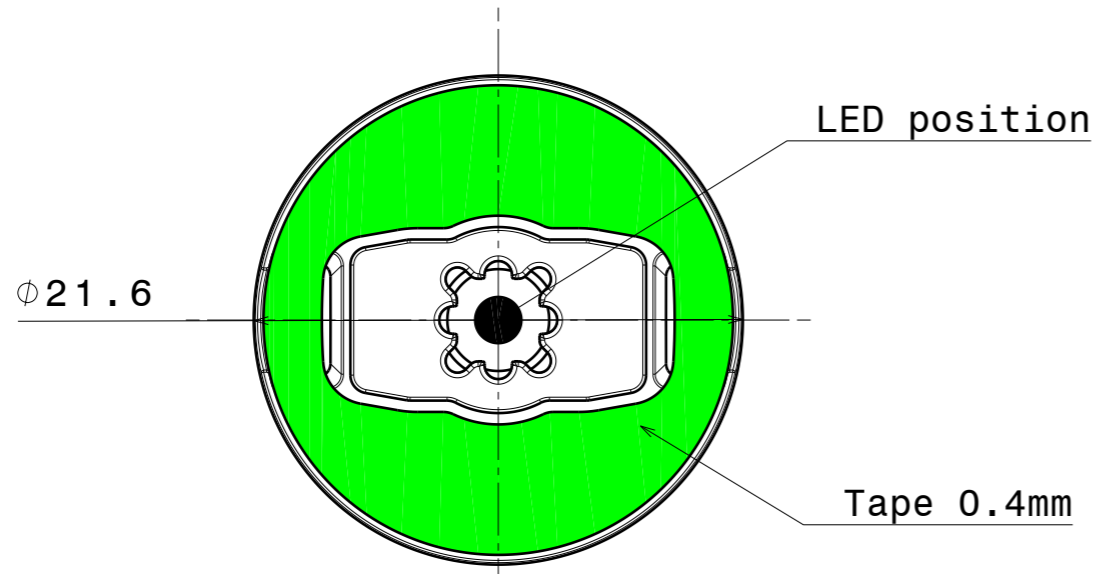

Bottom view
Scale: 3:1

INDEX	DESCRIPTION	MATERIAL	COLOUR
1	Lens	PMMA	
2	Holder	PC	black
3	Tape	PU 2-sided foam tape	adhesive

Tolerances if not otherwise shown
According to DIN ISO 2768-1
Linear measures:
Up to 30mm class M, otherwise class C.
According to DIN ISO 2768-2
Form and position: class L

LEDiL LediL Oy
Salorankatu 10
FIN 24240 SALO
Finland

THIRD ANGLE PROJECTION:

DRAWING TITLE
Datasheet_LXP-Series

This drawing is the property of LEDiL Oy. It may not be reproduced, copied or communicated without a written agreement with LEDiL Oy.

SIZE PART NUMBER
A3 -

SCALE 3:1 WEIGHT - SHEET 1/1

H G B A

Ledil Oy FA10660_LXP-M FA10660_LXP-M / LDC (Linear)

Luminaire: Ledil Oy FA10660_LXP-M FA10660_LXP-M
Lamps: 1 x Cree XP-E (White)

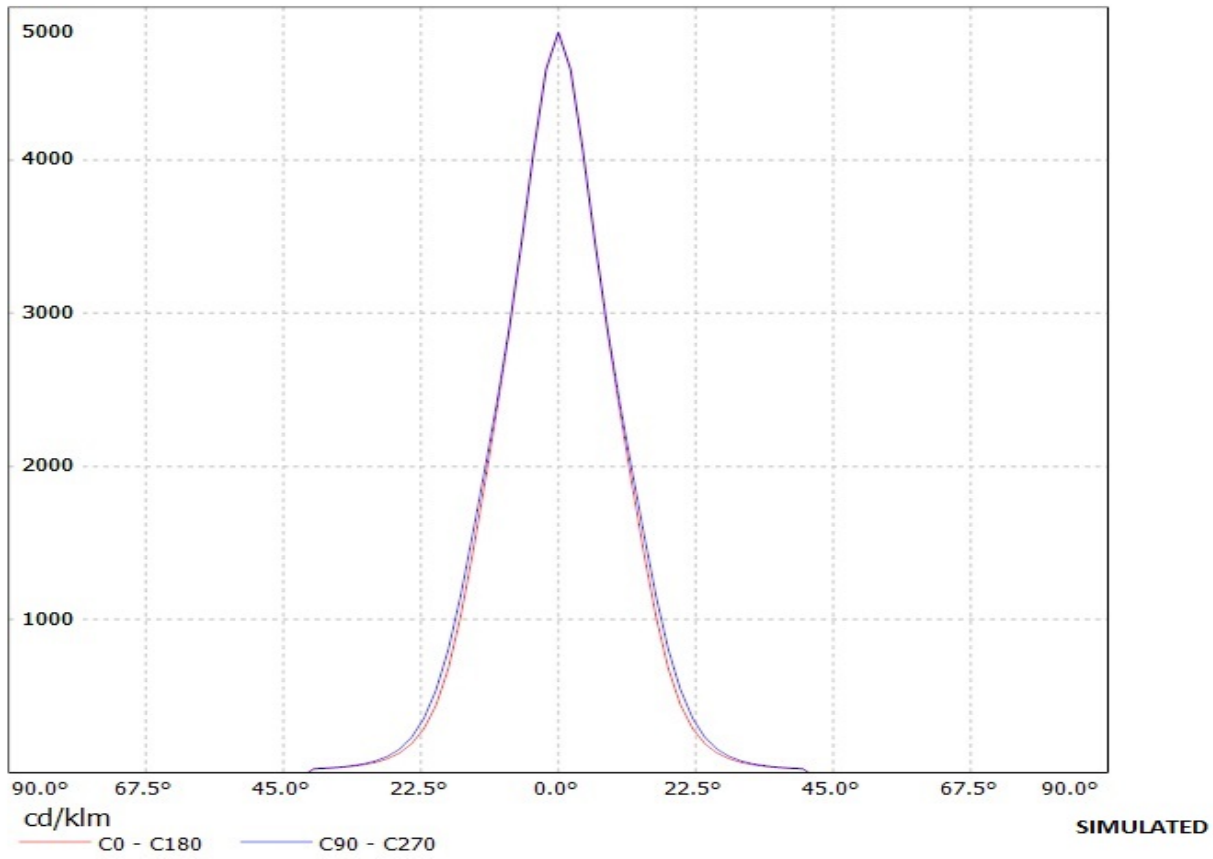

Luminaire: Ledil Oy FA10060_LXP-M (Cree XT-E 100lm @ 250mA) Efficiency=87%
Lamps: 1 x Cree XT-E 100lm @ 250mA

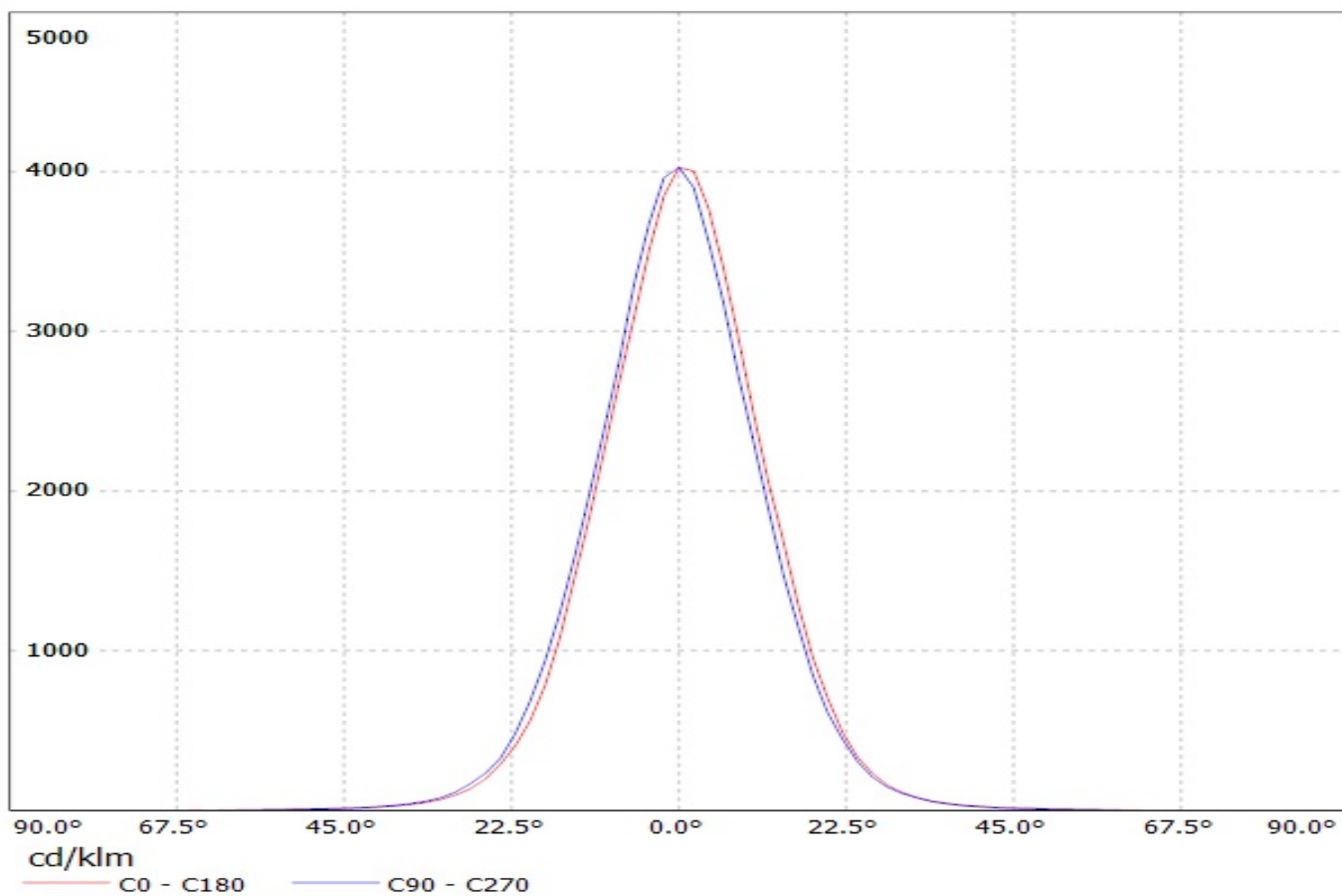

Luminaire: Ledil Oy FA10660_LxP-M_(XP-G2) Efficiency=87%
Lamps: 1 x Cree XP-G2 (104lm@250mA) CCT=6600K P=0.8W I=250mA

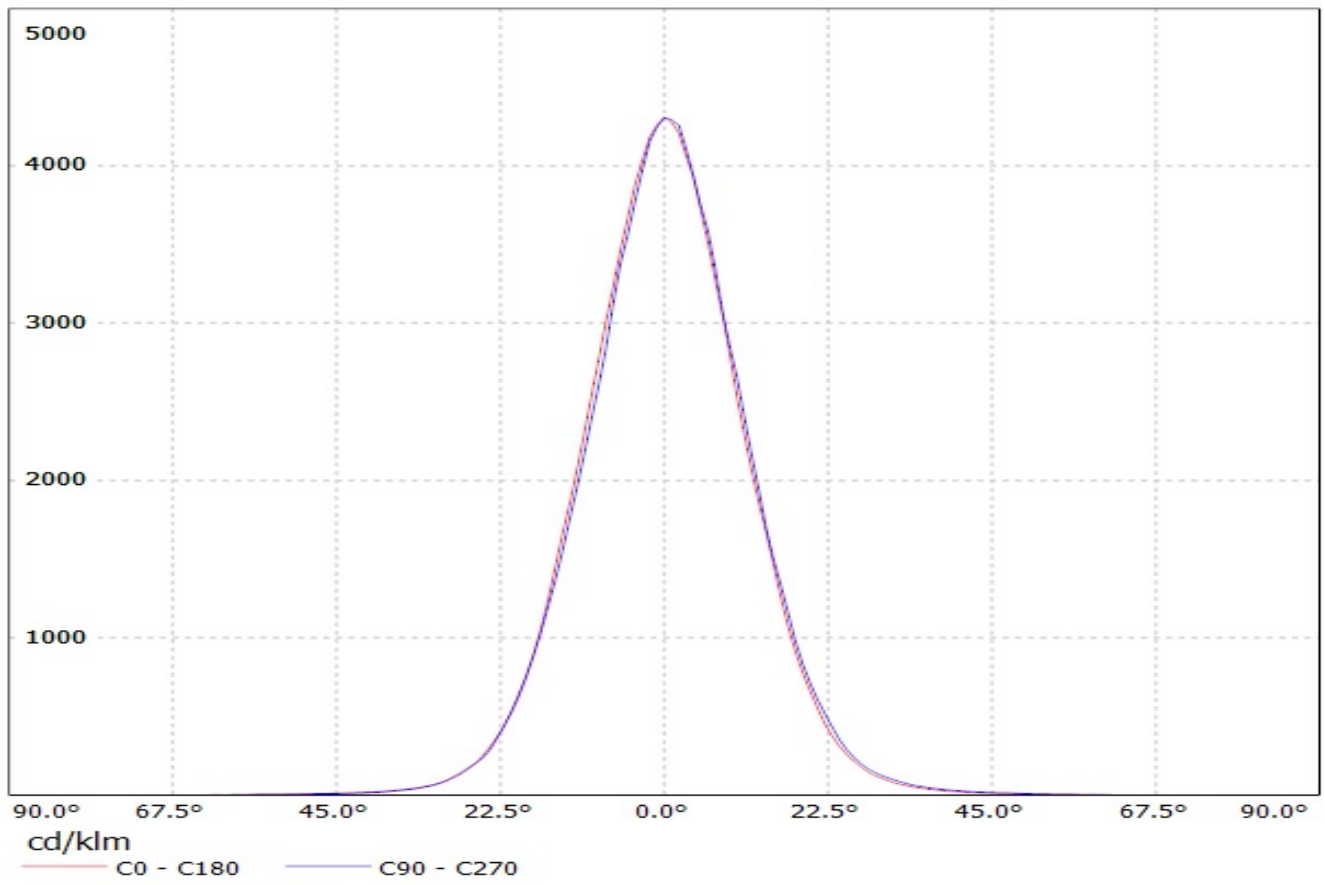

Ledil FA10660_LXP-M_(XP-L_HI) / LDC (Linear)

Luminaire: Ledil FA10660_LXP-M_(XP-L_HI)

Lamps: 1 x CREE_XP-L_HI_116.971lm@250mA_P=0.75W_I=0.25A

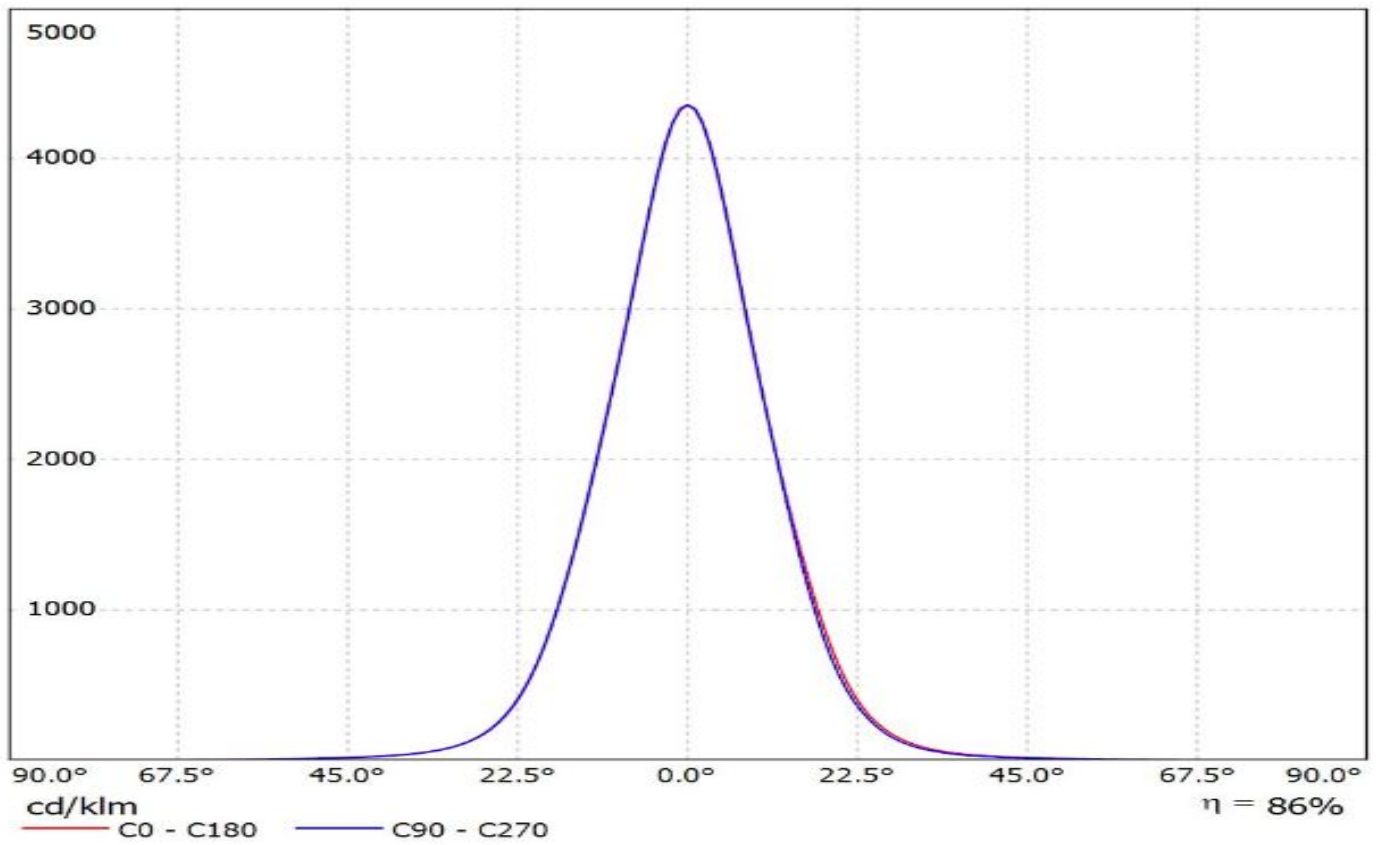

Luminaire: Ledil Oy FA10660_LXP-M (Samsung LH351A 86lm @ 250mA) Efficiency=90%
Lamps: 1 x Samsung LH351A 86lm @ 250mA

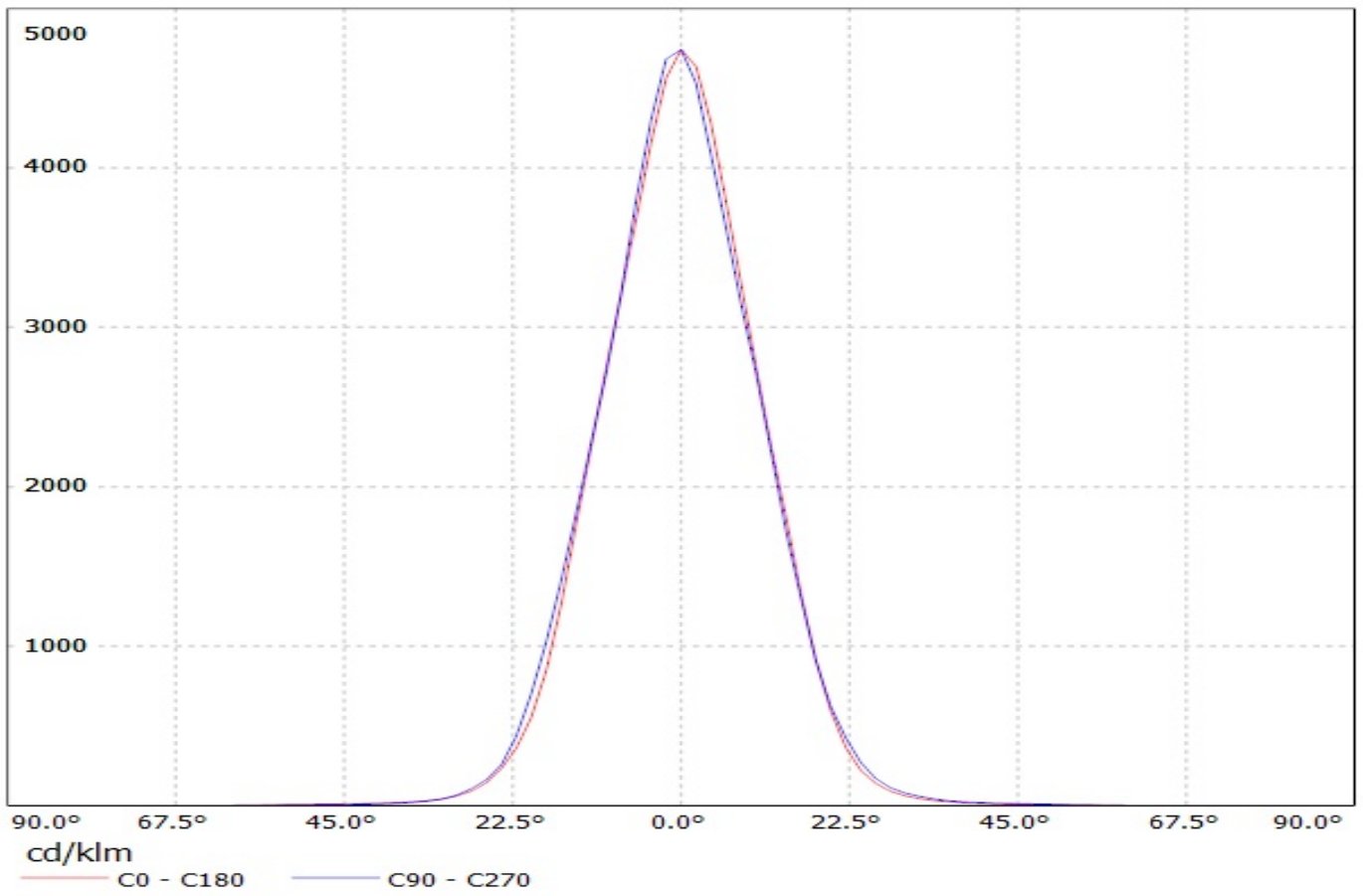

Ledil Oy FA10660_LXP-M FA10660_LXP-M / LDC (Polar)

Luminaire: Ledil Oy FA10660_LXP-M FA10660_LXP-M

Lamps: 1 x Cree XP-E (White)

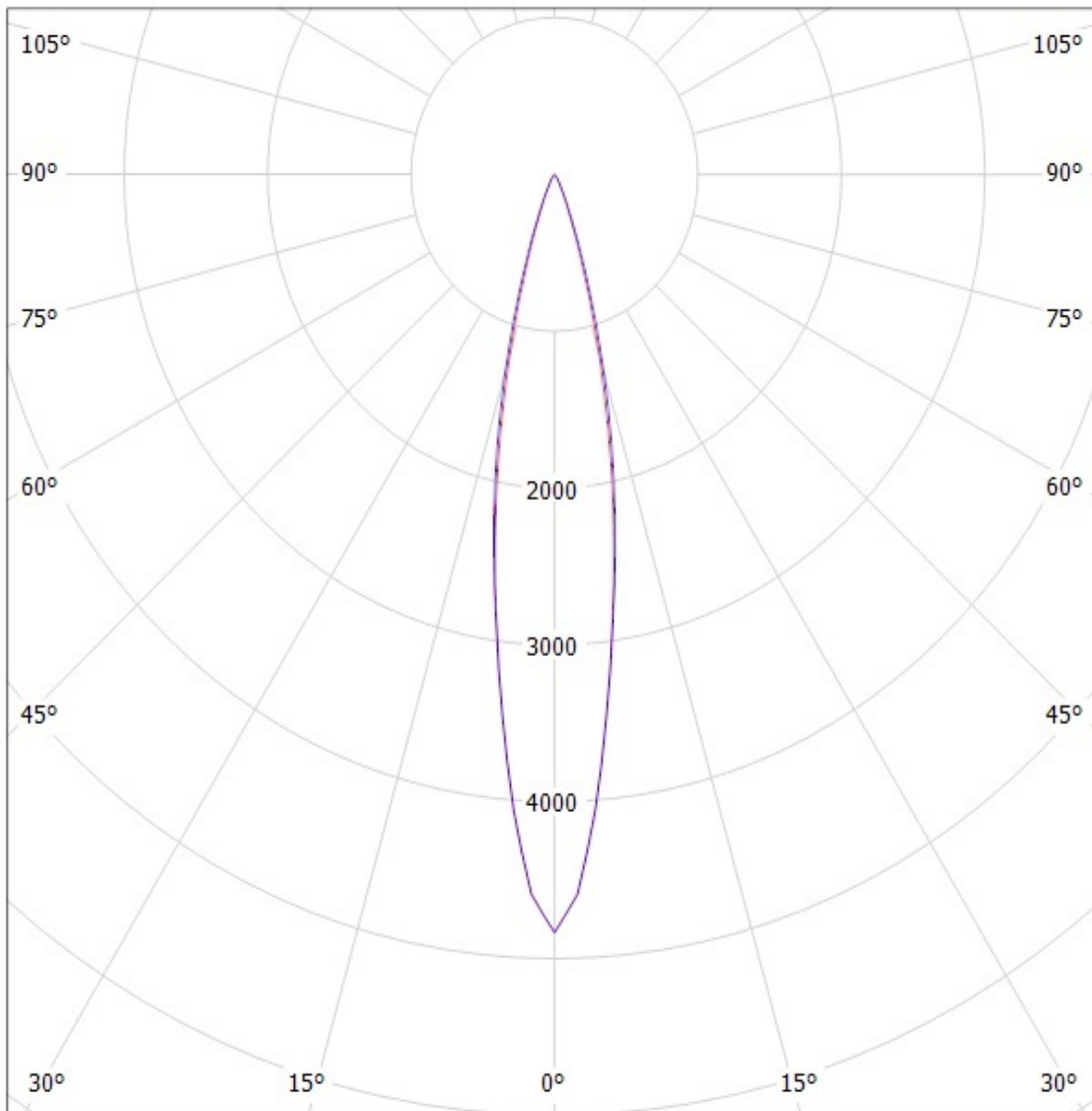

cd/klm

— C0 - C180

— C90 - C270

SIMULATED

Luminaire: Ledil Oy FA10060_LXP-M (Cree XT-E 100lm @ 250mA) Efficiency=87%
Lamps: 1 x Cree XT-E 100lm @ 250mA

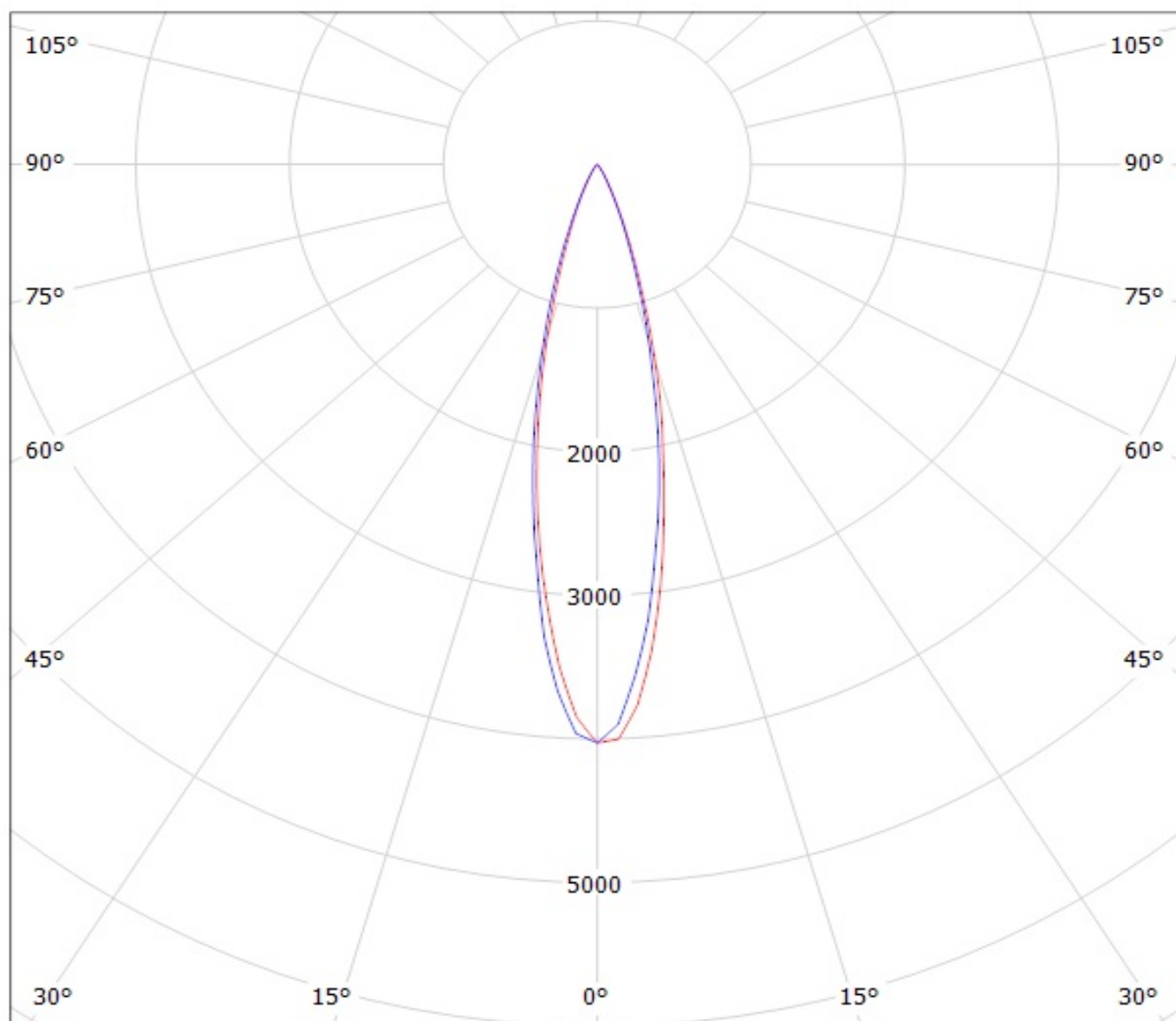

cd/klm

— C0 - C180

— C90 - C270

Luminaire: Ledil Oy FA10660_LxP-M_(XP-G2) Efficiency=87%
Lamps: 1 x Cree XP-G2 (104lm@250mA) CCT=6600K P=0.8W I=250mA

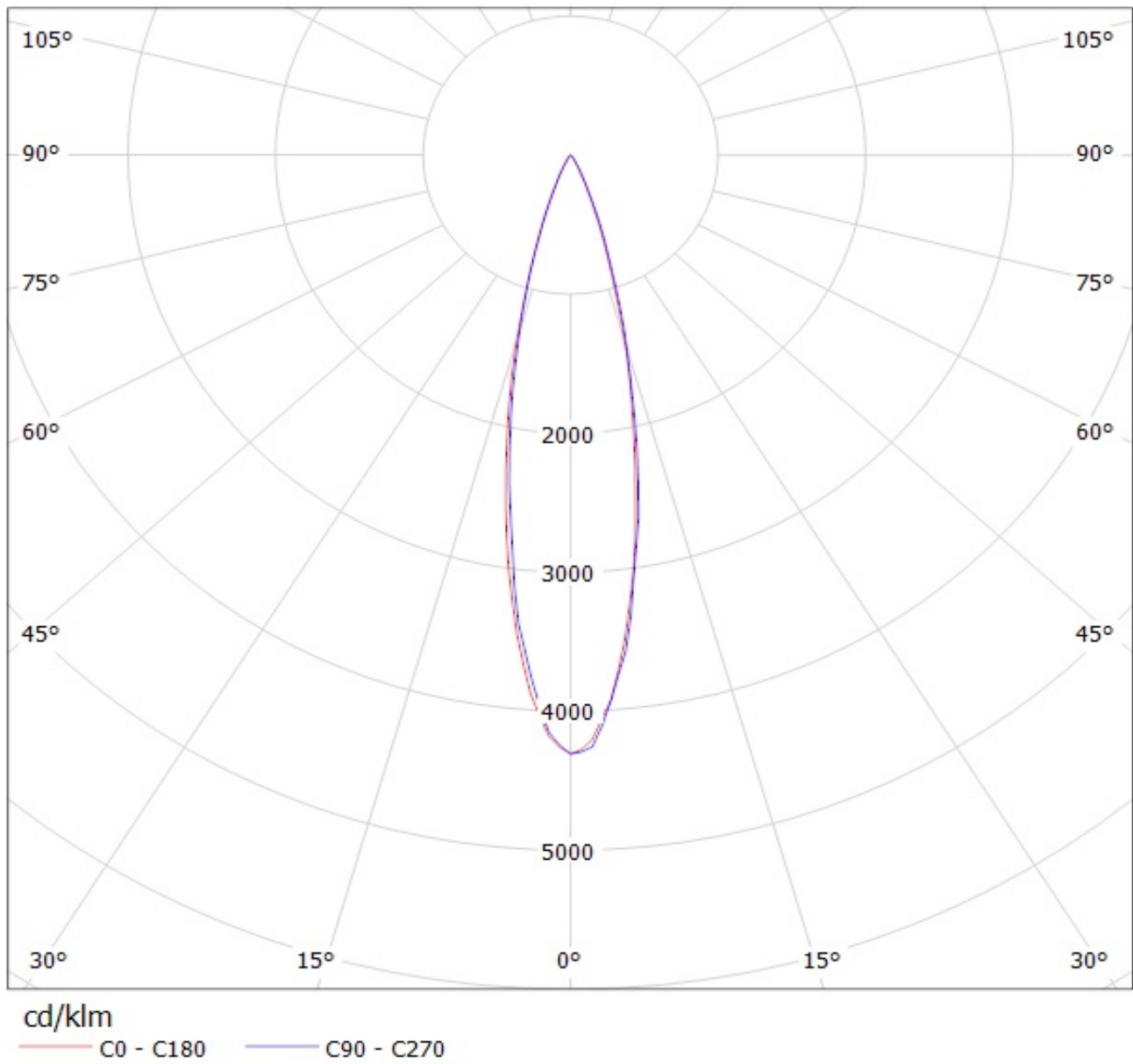

Ledil FA10660_LXP-M_(XP-L_HI) / LDC (Polar)

Luminaire: Ledil FA10660_LXP-M_(XP-L_HI)

Lamps: 1 x CREE_XP-L_HI_116.971lm@250mA_P=0.75W_I=0.25A

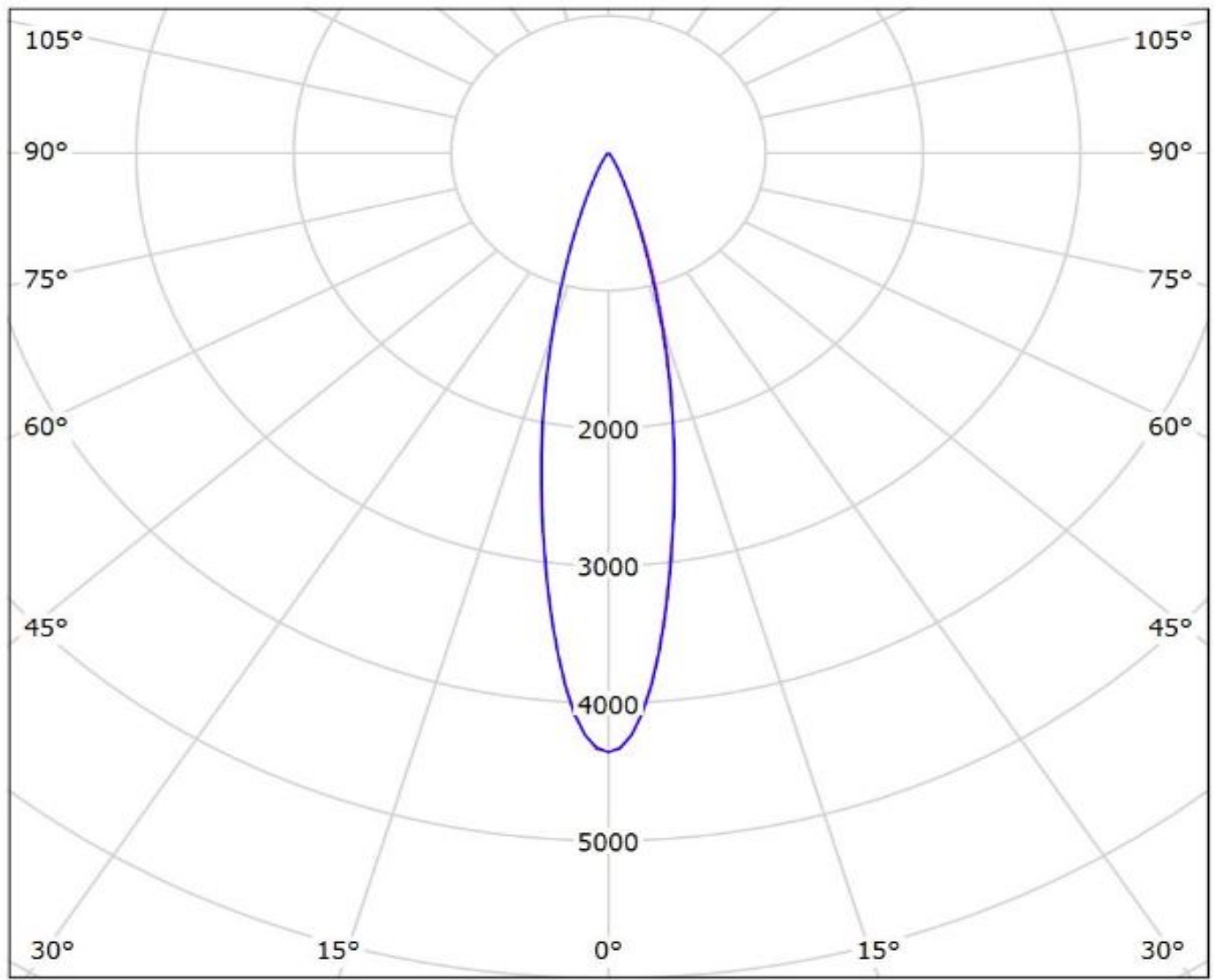

cd/klm

— C0 - C180

— C90 - C270

$\eta = 86\%$

Luminaire: Ledil Oy FA10660_LXP-M (Samsung LH351A 86lm @ 250mA) Efficiency=90%
Lamps: 1 x Samsung LH351A 86lm @ 250mA

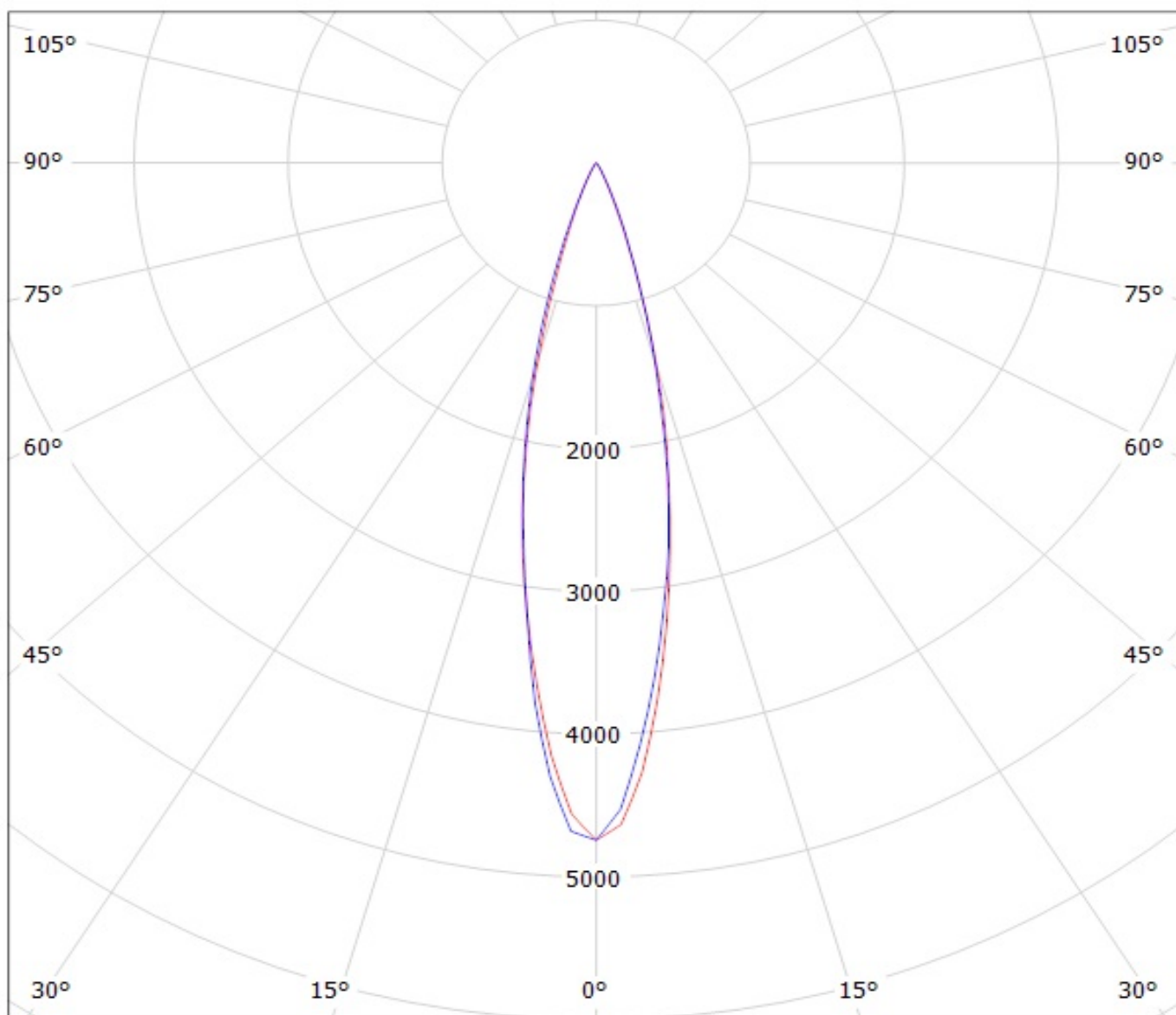

cd/klm

— C0 - C180 — C90 - C270

NOTE: The typical divergence will be changed by different color, chip size and chip position tolerance. The typical total divergence is the full angle measured where the luminous intensity is half of the peak value.