

## Outline Dimension

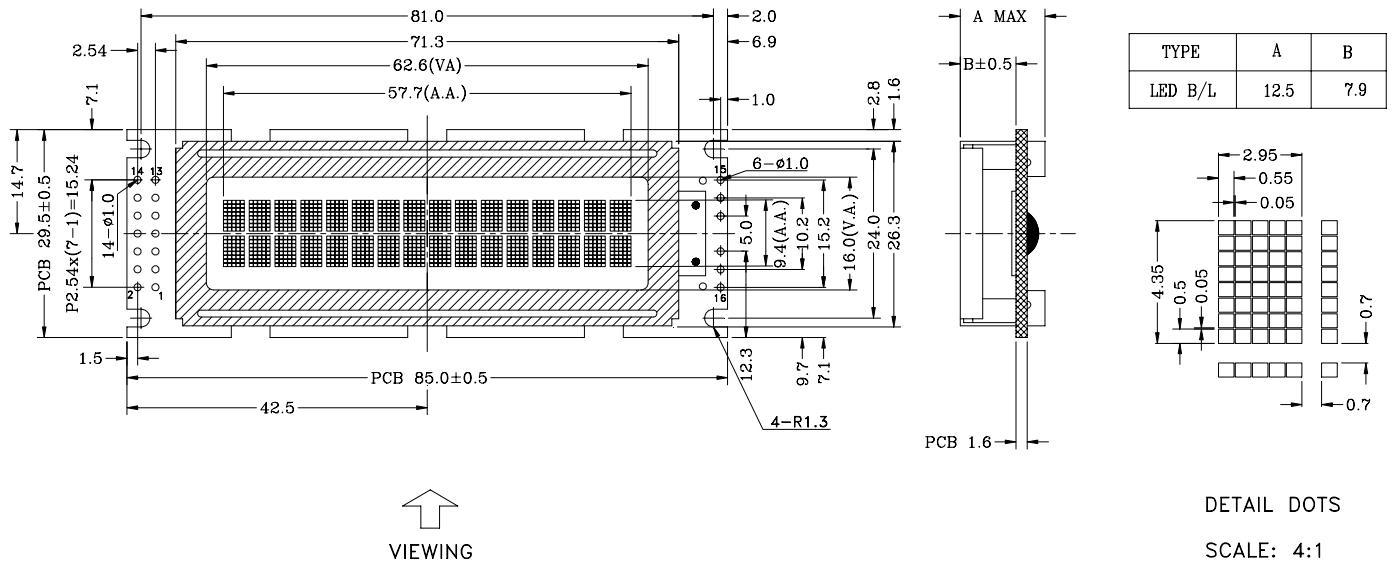

## Character Type

### Feature :

- 16X2 Characters
- STN/TRANSFLECTIVE/POSITIVE/Y-G
- Yellow green/bottome-light (LED)
- Operating Temp.: -10°C ~ +60°C
- 1/16 duty cycle, 1/5 Bias
- Built-in Controller (SPLC780D1 or equivalent)
- Viewing angle: 6 o'clock

### Absolute Maximum Rating :

Item	Symbol	Standard value			Unit
		M <sub>IN</sub>	T <sub>YP</sub>	M <sub>AX</sub>	
Power supply for logic	V <sub>DD</sub> -V <sub>SS</sub>	-0.3	--	7.0	V
Input voltage	V <sub>I</sub>	-0.3	--	V <sub>DD</sub> +0.3	V

### Adjusting Display Contrast :

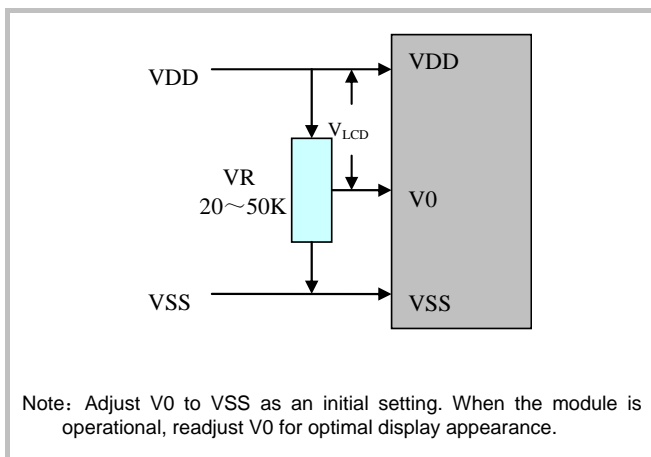

### Electrical Characteristic :

(V<sub>SS</sub>=0V, T<sub>a</sub> = 25°C)

Parameter	Symbol	Condition	M <sub>I</sub>	T <sub>YP</sub>	M <sub>AX</sub>	Unit
Supply voltage for logic	V <sub>DD</sub>	--	4.8	5.0	5.2	V
Supply current for logic	I <sub>DD</sub>	--	--	1.5	--	mA
Operating voltage for LCD	V <sub>LCD</sub>	-10°C	--	--	--	V
		+25°C	--	5.0	--	V
		+60°C	--	--	--	V
Supply voltage for Backlight	V <sub>BL</sub>	--	4.2	--	V	
Supply current for Backlight	I <sub>BL</sub>	--	100	--	mA	

### Interface Pin Connections :

Pin No.	Symbol	Level	Description
1	VSS	0V	Ground.
2	VDD	+5.0V	Supply voltage for logic operating.
3	V0	--	Adjusting voltage for LCD driving (variable).
4	RS	H/L	A signal for selecting registers: 1: Data Register (for read and write) 0: Instruction Register (for write), Busy flag-Address Counter (for read).
5	R/W	H/L	R/W = "H": Read mode. R/W = "L": Write mode.
6	E	H/L	An enable signal for writing or reading data.
7~14	DB0-DB7	H/L	8-bit bi-directional data bus.
15	LED+	5.0V	Power supply for backlight
16	LED-	--	The backlight ground