

SPECIFICATION OF CERAMIC FILTER

LT5.5MB

1. SCOPE

THIS SPECIFICATION SHALL COVER THE CHARACTERISTICS OF THE CERAMIC FILTER WITH LT5.5MB

2. SPECIFICATION NO. : SL011

3. PART NO. : LT5.5MB

4. ELECTRICAL SPECIFICATIONS

4.1 CENTRE FREQUENCY (F_o) : 5.5+/-0.55kHz

4.2 BAND WIDTH AT (3 dB) : +/-75KHZ

4.3 20db Band Width[KHZ]Max : 550kHz[Max]

4.4 Spurious Response [min] : 25dB

4.5 INSERTION LOSS : 6.0dB max

4.6 INPUT/OUTPUT IMPEDANCE : 600Ω

NOTE : CENTER FREQUENCY SHALL BE DEFIED AS THE CENTRAL VALUE OF THE BAND WITH AT 3dB

5 MEASUREMENT

5.1 ENVIRONMENTAL CONDITION

MEASUREMENT SHALL BE CARRIED OUT AT THE REFERENCE TEMPERATURE OF 25°C ±2°C. IT SHALL BE POSSIBLY DONE AT 5°C TO 35°C UNLESS IT IS QUESTIONABLE.

5.2 MEASUREMENT CIRCUIT

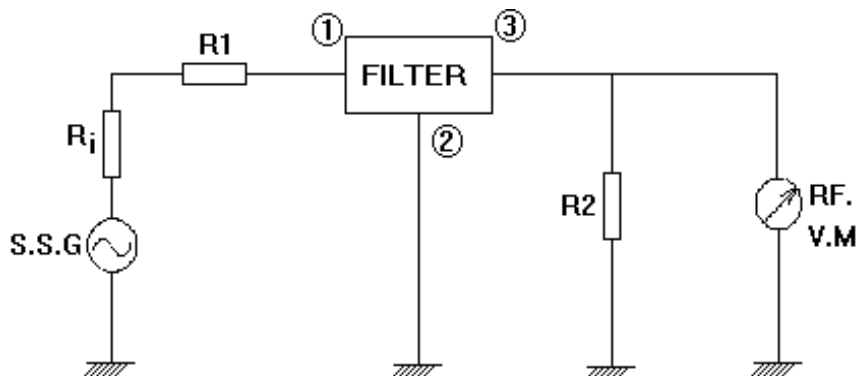

$$(R_i + R_1) = R_2 = 600\Omega$$

① Input ② Ground ③ Output

6. ENVIRONMENTAL CHARACTERISTICS

6-1 MOISURE

KEEP THE FILTER AT $40^{\circ}\text{C} \pm 2^{\circ}\text{C}$ AND 90 ~ 95% RH FOR 96 ± 4 HOURS. THEN, RELEASE THE FILTER INTO THE ROOM CONDITIONS FOR 1 HOUR PRIOR TO THE MEASUREMENT. IT SHALL FULFILL THE SPECIFICATIONS IN TABLE 1.

6-2 VIBRATION

SUBJECT THE FILTER TO THE VIBRATION FOR 1 HOUR EACH IN THE X, Y AND Z AXES WITH THE AMPLITUDE OF 1.5 mm AT 10 ~ 55 Hz. IT SHALL FULFILL THE SPECIFICATIONS IN TABLE 1.

6-3 MECHANICAL SHOCK

DROP THE FILTER RANDOMLY ONTO A CONCRETE FLOOR FROM THE HEIGHT OF 30cm 3 TIMES. IT SHALL FULFILL THE SPECIFICATIONS IN TABLE 1.

6-4 RESISTANCE TO SOLDER HEAT

DIP THE FILTER TERMINALS NO CLOSER THAN 1.5mm INTO THE SOLDER BATH AT $270^{\circ}\text{C} \pm 10^{\circ}\text{C}$ FOR 10 ± 1 SEC. THE FILTER SHALL MEET THE SPECIFICATIONS IN TABLE 1.

6-5 SOLDERABILITY

DIP THE FILTER TERMINALS NO CLOSER THAN 1.5mm INTO THE SOLDER BATH AT $230^{\circ}\text{C} \pm 5^{\circ}\text{C}$ FOR 5 ± 1 SEC. MORE THAN 95% OF THE TERMINAL SURFACE OF THE FILTER SHALL BE COVERD WITH FRESH SOLDER.

6-6 HIGH TEMPERATURE EXPOSURE

SUBJECT THE FILTER TO $-30 \pm 5^{\circ}\text{C}$ FOR 96 ± 4 HOURS. THEN, RELEASE THE FILTER INTO THE ROOM CONDITIONS FOR 1 HOUR PRIOR TO THE MEASUREMENT. IT SHALL MEET THE SPECIFICATIONS IN TABLE 1.

6-7 LOW TEMPERATURE EXPOSURE

SUBJECT THE FILTER TO $-30 \pm 5^{\circ}\text{C}$ FOR 96 ± 4 HOURS. THEN, RELEASE THE FILTER INTO THE ROOM CONDITIONS FOR 1 HOUR PRIOR TO THE MEASUREMENT. IT SHALL MEET THE SPECIFICATIONS IN TABLE 1.

6-8 TEMPERATURE CYCLING

SUBJECT THE FILTER TO A LOW TEMPERATURE OF -30°C FOR 30 MINUTES. FOLLOWED BY A HIGH TEMPERATURE OF $+80^{\circ}\text{C}$ FOR 30 MINUTES. CYCKING SHALL BE REPEATED 5 TIMES WITH A TRANSFER TIME 15 MINUTES. AT THE ROOM CONDITIONS. THEN, RELEASE THE FILTER INTO THE ROOM TEMCONDITIONS FOR 1 HOUR PRIOR TO THE MESUREMENT. IT SHALL MEET THE SPECIFICATIONS IN TABLE 1.

6-9-1PULLING TEST

WEIGHT ALONG WITH THE DIRECTION OF LEAD WITHOUT AN SHOCK 3 KG. THE FILTER SHALL SHOW NO EVIDENCE OF DAMAGE AND SHALL SATISFY ALL THE INITIALL ELECTRIC CHARACTERISTICS

6-9-2 BENDING TEST

LEAD SHALL BE SUBJECTED TO WITHSTAND AGAINST 90 BENDING IN THE DIRECTION OF THICKNESS. THIS OPERATION SHALL BE DONE TOWARD BOTH DIRECTION. THE FILTER SHALL SHOW NO EVIDENCE OF DAMAGE AND SHALL SATISFY ALL THE INITIAL ELECTRICAL

7. DIMENSIONS(mm)