

## SPECIFICATION FOR CERAMIC CHIP TYPE RESONATOR

TYPE: ZTTCC6.00MHZ

### 1 Scope

This specification shall cover the characteristics of the ceramic resonator (Chip type) 6.00MHZ for clock oscillation circuit of such as microprocessors.

### 2.Model Name

- 2-1 Model Name : ZTTCC6.00MG
- 2-2 Specification No :
- 2-3 Customer's Part Number :
- 2-4 Customer's drawing Number:

### 3 Outline Drawing and Dimensions

- 3-1 Appearance : No visible damage and dirt
- 3-2 Dimensions :

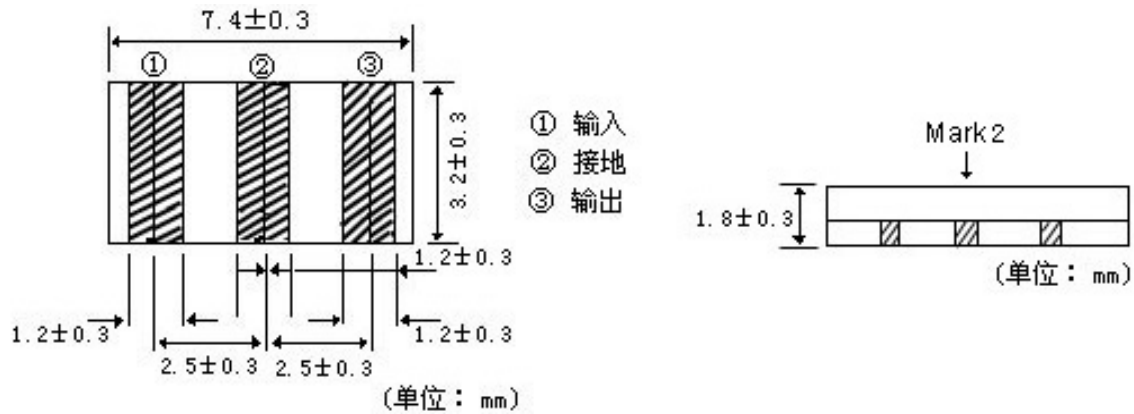

### 4 Ratings and Characteristics

	Item	Requirements
4-1	Nominal Oscillating Frequency	6.00MHZ
4-2	Initial Tolerance	±0.50%max
4-3	Resonant Resistance	30 Ω max
4-4	Insulation Resistance	5×10 <sup>8</sup> Ω min(Applied D.C.10V)
4-5	Withstanding Voltage	D.C.100V 5 seconds max.
4-6	Rating Voltage (1). D.C. Voltage (2). A.C. Voltage	D.C.6V 15 Vp-p.
4-7	Temperature Stability (-20℃ to +80℃) Operating Temperature Storage Temperature	±0.30%max. (from initial value) -20℃ to +80℃ -30℃ to +85℃
4-8	Aging (for 10 years)	±0.30%max. (from initial value)

## 5. Physical Characteristics

	Test Item	Condition of Test	Performance Requirements
5-1	Random Drop	Resonator shall be measured after 3 times random drops from the height of 1.0m on concrete floor.	No visible damage and the measured values shall meet Table 1.
5-2	Vibration	Resonator shall be measured after being applied vibration of amplitude of 1.5mm with 10 to 55HZ band of vibration frequency to each of 3 perpendicular directions for 1 hours.	The measured values shall meet Table 1.
5-3	Resistance to soldering Heat	Lead terminals are immersed up to 1.5mm from resonator's body in solder bath of $260 \pm 5^{\circ}\text{C}$ for $10 \pm 1$ seconds, and then resonator shall be measured after being placed in natural condition for 1 hour.	The measured values shall meet Table 1.
5-4	Solderability	Lead terminals are immersed in resin for 5 seconds and then immersed in soldering bath of $230 \pm 5^{\circ}\text{C}$ for $3 \pm 0.5$ seconds.	95% min. lead terminals shall be wet with solder.
5-5	Terminal Strength	After force 10 seconds of 1.0Kg is applied to each terminal in axial direction, resonator shall be measured.	No visible damage and the measured values shall meet Table 1. No cutting off.

## 6 Environmental Characteristics

	Test Item	Condition of Test	Performance Requirements
6-1	High Temperature	After being placed in a chamber with $85 \pm 2^{\circ}\text{C}$ for $96 \pm 4$ hours and then being placed in natural condition for 1 hour. Resonator shall be measured.	The measured values shall meet Table 1.
6-2	Low Temperature	After being placed in a chamber with $-30 \pm 2^{\circ}\text{C}$ for $96 \pm 4$ hours and then being placed in natural condition for 1 hour. Resonator shall be measured..	The measured values shall meet Table 1.
6-3	Humidity	After being placed in a chamber with 90 to 95% R.H. at $+60 \pm 2^{\circ}\text{C}$ for $96 \pm 4$ hours and then being placed in natural condition for 1 hour. Resonator shall be measured..	The measured values shall meet Table 1.
6-4	Heat Shock	After being kept at room temperature, resonator shall be placed at temperature of $-30^{\circ}\text{C}$ , After 30 minutes at this temperature, resonator shall be immediately placed at temperature of $+85^{\circ}\text{C}$ . After 30 minutes at this temperature, resonator shall be returned to $-30^{\circ}\text{C}$ again, after 5 above cycles, resonator shall be returned to room temperature. And resonator shall be measured after being placed in natural condition for 1 hour.	The measured values shall meet Table 1.

**Table 1**

Measurements	Requirements
Oscillating Frequency	$\pm 0.3\%$ max. (from initial value)
Resonant Resistance	$\Delta R1 < 5 \Omega$

**7 Test Circuit**

7-1 Oscillating Frequency: Please note that the T series oscillates stably even if terminal (1) and (3) is connected reversibly, but it may cause a little frequency lag.

7-2 Equivalent Circuit Constants: Network Analyzer Hp87510A or Equivalent.

7-3 measuring condition: Temperature  $+25 \pm 3^\circ\text{C}$

Humidity 60 to 10% R.H

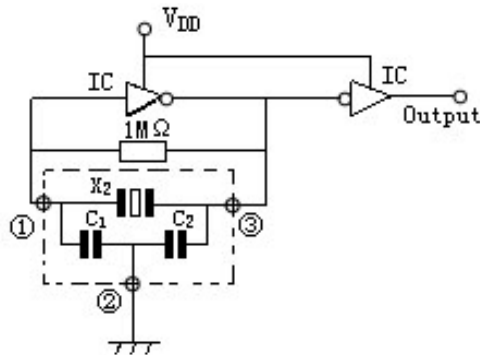

VDD=+5V

C1=C2=30PF

IC: 1/6CD4069UBE(RCA) X 2

**8 Recommended re-flow soldering standard conditions**

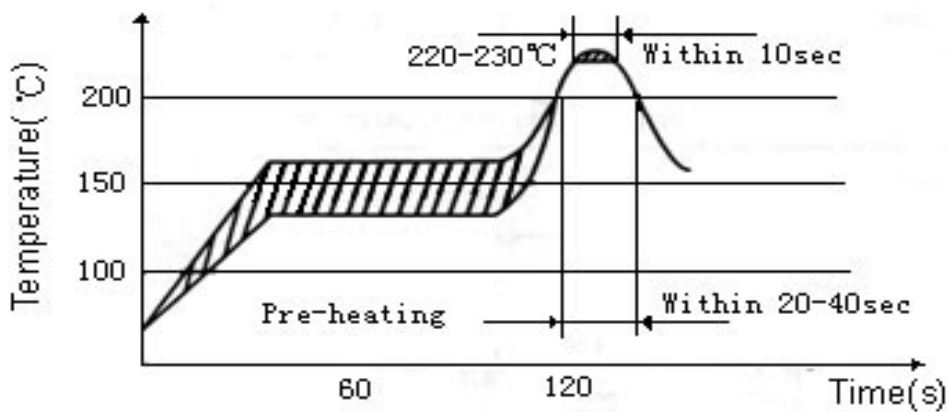

Notice:

1. In case of immersing in cleaning solvent, the temperature of component must be returned to room temperature after soldering
2. Please insure the component is thoroughly evaluated in your application circuit