

# SPECIFICATION

Product : Topview 3528 White SMD LED

Part No : IWS-351-UW-A2

Customer :

Date : 2006. 5. 12 Ver.1.0

**Customer :**

Checked By	Checked By	Checked By	Checked By	Approval

**Manufacturer : ITSWELL Co., LTD**

Proposed By	Checked By	Checked By	Checked By	Approval
				

**Comment**



Suwon Company :

442-190, 802 Uman Industrial Complex, 300-5 Uman-dong, Paldal-gu, Gyeonggi-do, Korea  
Tel:+82-31-244-0002, FAX:+82+31-244-1806

Ochang Company :

363-880, 9-4Block, Ochang Scientific Industrial Complex, Ochang, Cheongwon, Chungbuk, Korea  
URL : www.itswell.com, TEL : int) 82-43-218-1800, FAX.: int) 82-43-218-1805

# Topview 3528 SMD LED

## IWS-351-UW-A2



### 1. Features

- 1 chip high-luminous intensity Chip LED
- 3.5 mm x 2.8 mm x 1.8 mm (L x W x H) small size surface mount type
- Wide Viewing angle
- Long operating life

### 2. Applications

- Automotive: Backlight in dashboard and switch
- Lighting device: Indicator, lighting
- Camera flash, Hand Carrier Flash
- General use

### 3. Outline Drawing and Dimension

Unit : mm  
Tolerance :  $\pm 0.1\text{mm}$

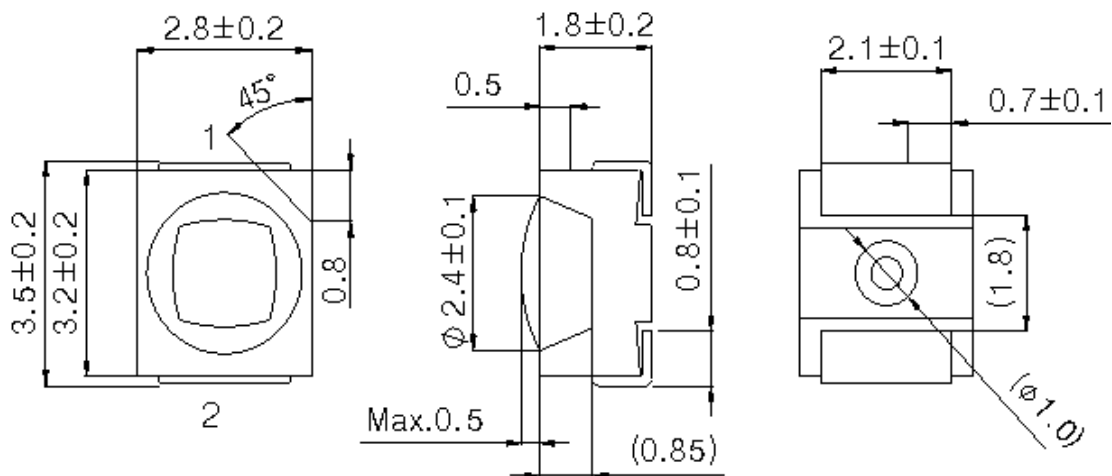

BLOCK DIAGRAM

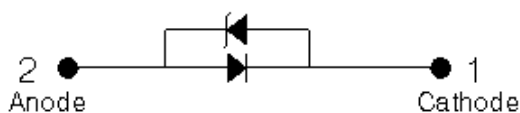

#### Note

1. All dimensions are in millimeters
2. All dimensions without tolerances are for reference only

### 4. Absolute Maximum Ratings( Ta = 25 □ )

Parameter	Symbol	Value	Unit
Power Dissipation	$P_d$	120	mW
Continuous Forward Current	$I_F$	30	mA
Peak Forward Current □ <sup>1</sup>	$I_{FP}$	100	mA
Reverse Current	$I_{RZ}$	100	mA
Operating Temperature	$T_{opr}$	-30 ~ 85	□
Storage Temperature	$T_{stg}$	-40 ~ 100	□
Soldering Temperature	$T_{sol}$	260 (5sec)	□

□<sup>1</sup> Duty ratio = 1/10, Pulse width = 0.1ms

### 5. Electro-optical Characteristics( Ta = 25 □ )

Parameter	Symbol	Conditions	Min.	Typ.	Max.	Unit.
Forward Voltage	$V_F$	$I_F = 20 \text{ mA}$	-	3.4	4.0	V
Reverse Voltage	$V_{RZ}$	$I_R = 5 \text{ mA}$	0.7	0.9	1.5	V
Luminous Intensity □ <sup>2</sup>	$I_v$	$I_F = 20 \text{ mA}$	820	1000	2200	mcd
Color Coordinates □ <sup>3</sup>	CIE x CIE y	$I_F = 20 \text{ mA}$	-	CIE x=0.30 CIE y=0.29	-	
View angle □ <sup>4</sup>	$2\theta_{1/2}$	$I_F = 20 \text{ mA}$	-	120	-	°

<sup>2</sup> Luminous Intensity is tested by a tester calibrated by CAS 140B(CIE LED\_B) and has an accuracy of 10%

<sup>3</sup> Color Coordinates has an accuracy of  $\pm 0.01$ .

<sup>4</sup> Viewing angle is the angle until 50% of brightness measured from the front part of LED.

#### 5.1 Luminous Intensity Rank

Rank	Luminous Intensity (mcd)
O	
P	820 - 1150
Q	1150 - 1600
R	1600 - 2200

#### 5.3 Forward Voltage

Rank	Forward Voltage (V)
a	3.0 - 3.2
b	3.2 - 3.4
c	3.4 - 3.6
d	3.6 - 3.8

#### 5.2 Color coordinates

Rank	CIE x, CIE y
A	Refer to 4 page
B	
C	

# Topview 3528 SMD LED

## IWS-351-UW-A2



### 5.2 Color coordinates Rank ( IF = 20 mA, Ta = 25 )

Rank A		Rank B		Rank C	
CIE x	CIE y	CIE x	CIE y	CIE x	CIE y
0.268	0.262	0.286	0.298	0.307	0.330
0.286	0.298	0.307	0.330	0.335	0.370
0.303	0.265	0.319	0.289	0.333	0.312
0.287	0.232	0.303	0.265	0.319	0.289

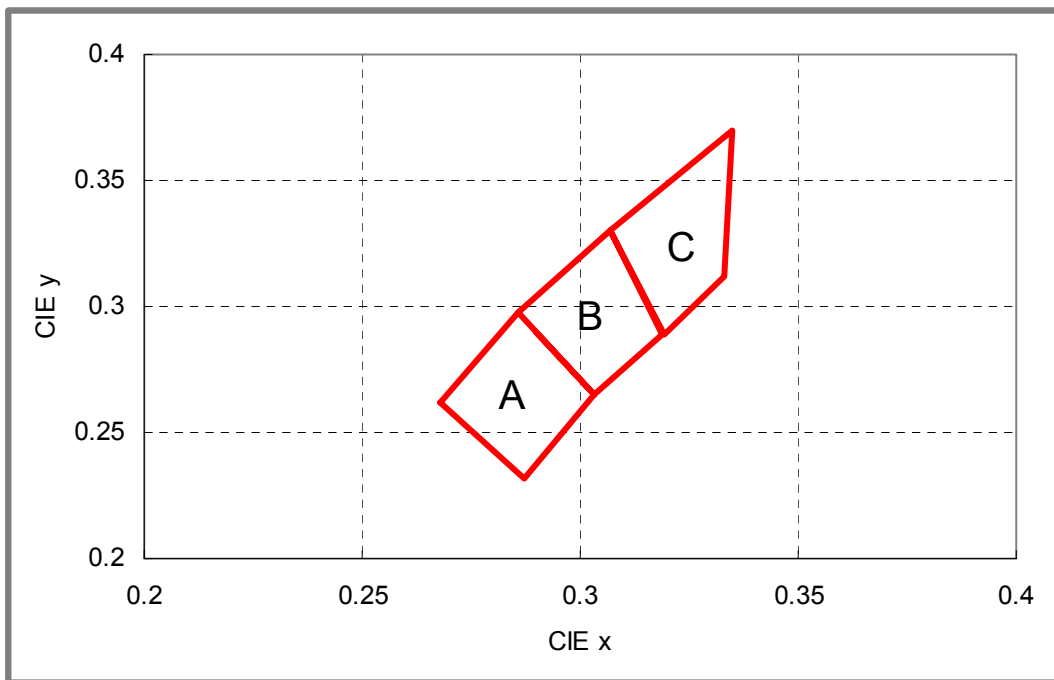

- \* The CIE(1931) standard colorimetric system
- \* Chromaticity coordinates Measured : 0.01sr(CIE. LED\_B)
- \* Measurement Uncertainty of the Color Coordinates :  $\pm 0.01$

### 6. Typical Characteristic Curves

**Forward Current vs. Forward Voltage**

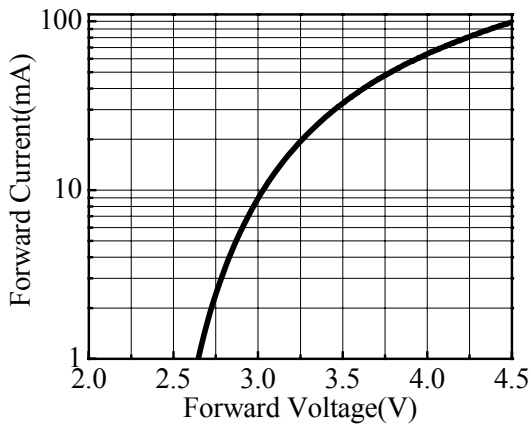

**Forward Current vs. Ambient Temperature**

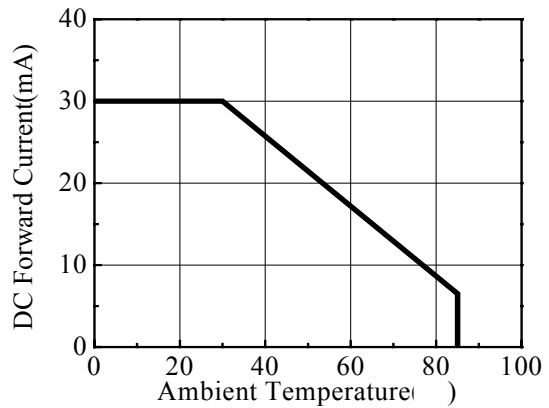

**Relative Luminous Intensity vs. Ambient Temperature**

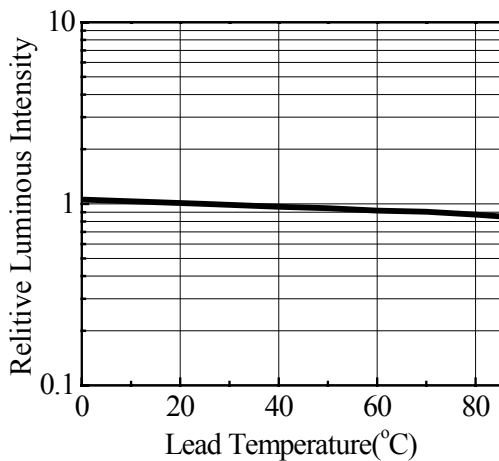

**Relative Luminous Intensity vs. Forward Current**

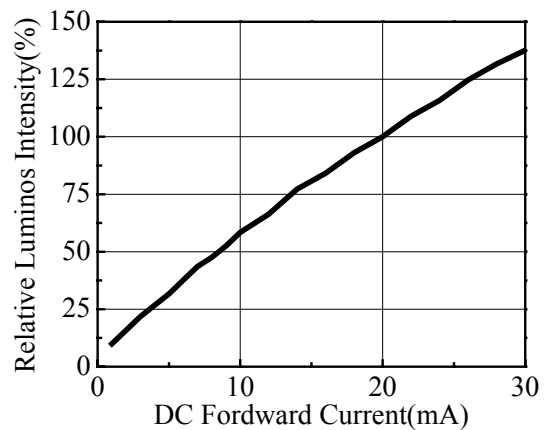

**Relative Intensity vs. Wavelength**

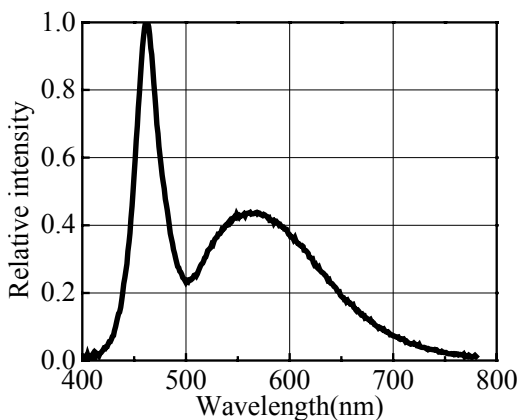

**Radiation Diagram**

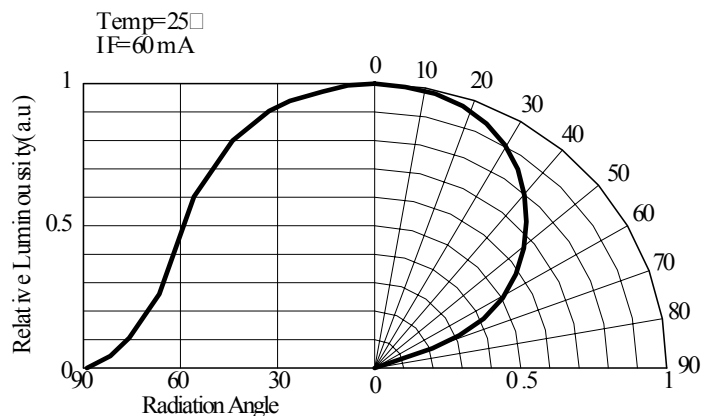

## 7. Dimension of Tape / Reel

### 7.1 Tape Dimension

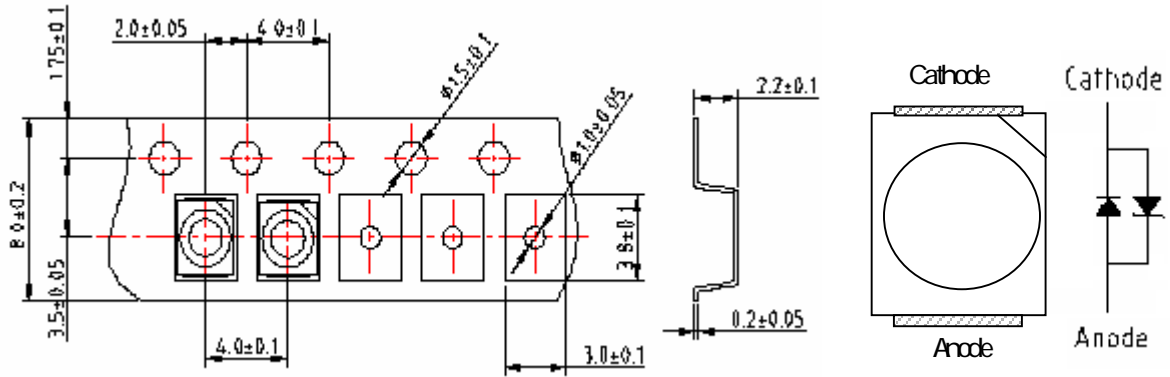

### 7.2 Reel Dimension

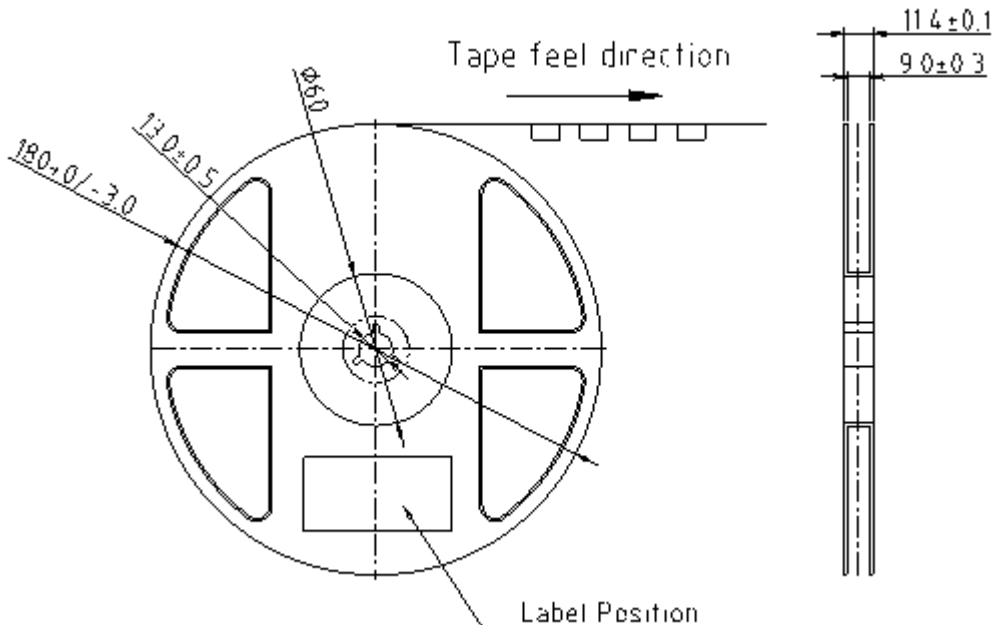

- Quantity : Product are packed in one taping reel of max. 2,000 pcs.
- Cumulative Tolerance : Cumulative Tolerance/10 pitches to be  $\pm 0.2\text{mm}$
- Adhesion Strength of Cover Tape : Adhesion strength to be 0.1-0.7N when the over tape is turned off from the carrier tape at  $10^\circ$  angle to be the carrier tape.
- Packaging : P/N, Manufacturing data Code No. and quantity to be indicated on a damp proof Package.

# Topview 3528 SMD LED IWS-351-UW-A2



## 8. Packing Dimension

Unit :mm

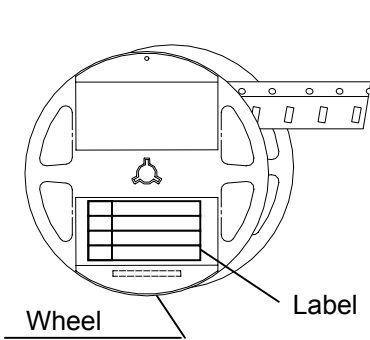

Diameter : 180 mm  
Width : 12 mm  
3528 2,000 pcs/Reel

Bake: 60°C, 4hrs

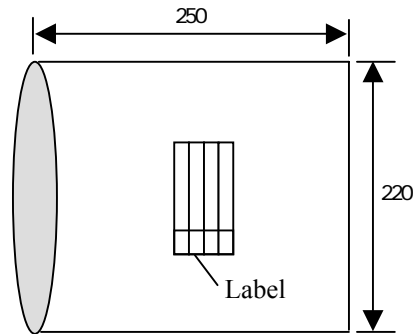

Shield Bag(Polyester/Al/LDPE)  
1 Reel/Bag ( T = 0.1 mm ) with Silica gel



### Al Pack & Reel Label, Box Label

(70 × 37)

		RANK #		
Lot :		MS-351-UW (A2)		
	MN	AG	MAX	SID
VF[volt]				
M[mcd]				
OE[x,y]				
Qty :		yyy/mm/dd		

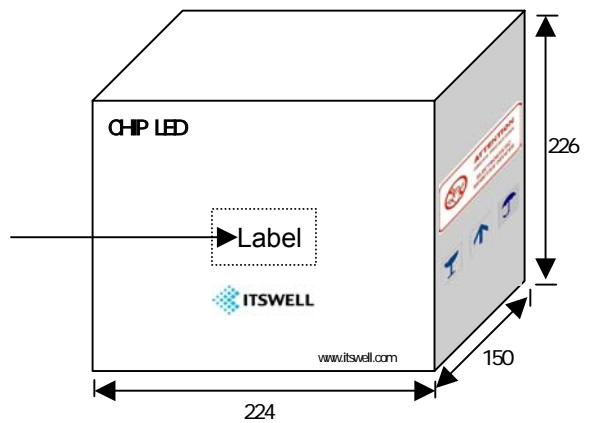

Maximum 10 Bags / 1 Inner Box  
3528 20,000 pcs / 1 Inner Box

## 9. Precaution in use

### 9.1 Soldering Conditions

- When soldering Power SMD, Heat may affect the electrical and optical characteristics of the LEDs.
- In soldering, do not stress the lead frame and the resin part under the high temperature.
- The silicone part should be protected from mechanical stress or vibration until the Power SMD return to room temperature after soldering.
- Preliminary heating to be at 150°C max. for 180 Seconds max.
- Soldering heat to be at 260°C max. for 5 sec. Max.
- For manual Soldering is Not more than 3 sec @MAX 350°C, under soldering iron

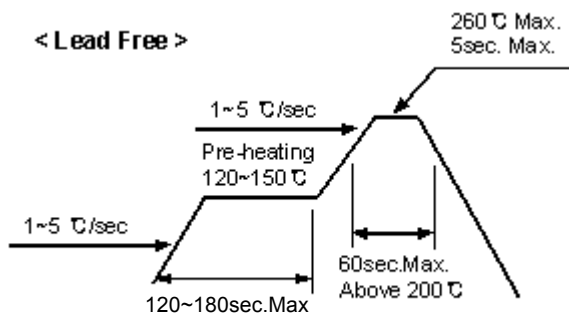

### <Recommendable soldering pattern>

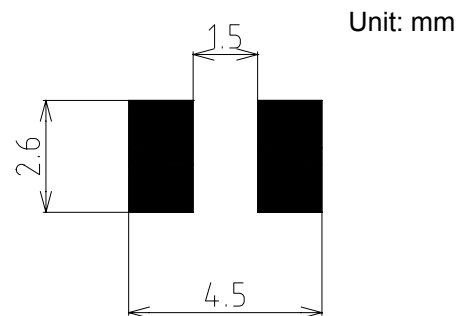

### 9.2 Storage

- Use within 7 days after opening packing. Store in 10 to 30°C. Power SMD lead frames are plated silver. The silver surface may be affected by environment which contains corrosive gases and so on. Please avoid conditions which may cause the Power SMD to corrode, tarnish or discolor.

### 9.3 Static Electricity

- Static electricity or surge voltage damages the Power SMD. It is recommended that a wrist band or an anti-electrostatic glove be used when handling the LEDs.
- A tip soldering iron is requested to be grounded. An ionizer should also be installed where there is a risk of static.
- All devices, equipment and machinery must be properly grounded (via 1MΩ). It is recommended that measures be taken against surge voltage to the equipment that mounts the Power SMD.

### 9.4 Cleaning

- Isopropyl Alcohol or Ethylene Alcohol is recommended in 5 minutes at room temperature. Don't use unspecified chemicals; they may cause cracks or haze on the surface of the epoxy resin.
- Before cleaning, a pre-test should be done to confirm whether any damage to the LED will occur.
- Freon solvents should not be used to clean the LEDs because of worldwide regulations.



### 10. Reliability

#### 10.1 Reliability Test Item

Test Items	Test Conditions	Notes
High Temperature Storage	100 500 hr.	0/32
Low Temperature Storage	-40 , 500 hr.	0/32
Temp. Humidity Storage	60 , 90 % RH, 500 hr.	0/32
Steady State Operating life	25 , 20 mA , 500 hr.	0/32
High Temperature Operating Life	85 , 20 mA, 500 hr	0/32
Low Temperature Operating Life	-30 , 20 mA, 500 hr.	0/32
Steady State Operating life Of High Humidity Heat	60 , 90 % RH, 20 mA, 300 hr.	0/32
Temperature Cycle	-40 (30min)→ 80 (30min) ; 100 cycle	0/22
ESD	HBM, 100 pF, 1.5 kohm, 3 times	0/22

#### 10.2 Criteria for Judging the Damage

Parameters	Test Conditions	Criteria for judgment
Forward Voltage ( $V_F$ )	$I_F = 20 \text{ mA}$	Less than 110% of U
Luminous Intensity ( $I_V$ )	$I_F = 20 \text{ mA}$	> 70% of S
Reverse Voltage ( $V_{ZR}$ )	$I_{ZR} = 5 \text{ mA}$	Less than 110% of U

\* U means the upper limit of specified characteristics, S means initial value.

### 11. Part Name Description

I W S - 351 - UW - A2

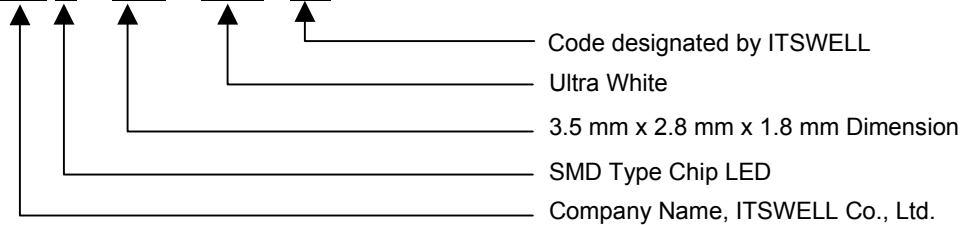

### 12. Rank Description

**P** **A** **b**

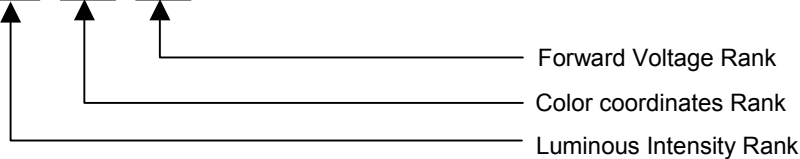

### 13. Attention : Electric Static Discharge (ESD) Protection



The symbol shown on the page herein to introduce 'Electro-Optical Characteristics'. ESD protection for GaP and AlGaAs based chips is still Necessary even though they are safe in low static-electric discharge. Material in AlInGaP, GaP, or/and InGaN based chips are STATIC SENSITIVE devices. ESD protection has to considered and taken in the initial design stage. If manual work/process is needed, please ensure the device is well protective From ESD during all the process. LED's ESD Level is 'Class II' and The range of Forward Voltage is 2000V ~ 3999V.

After opening the package, the LED's should be kept at 30%, 70%RH or less. The LEDs must be dip soldered within seven days(168 hours) after opening the moisture-proof packing. It is better not to use different rank LEDs. If use mixed rank, could not attain your object for highest quality of products.

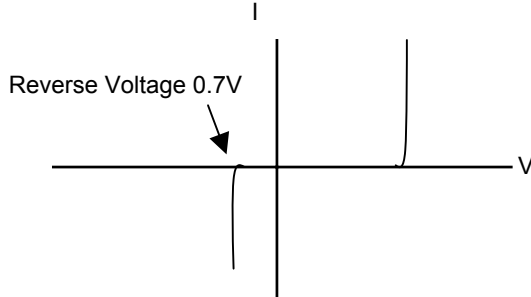

LED+Zener Diode

- Do not apply reverse voltage more than 0.7V.
- Product with Zener Diode is needed to discriminate the characteristics of product by fixing current and measuring voltage.

■ **Spec. Review History**

<b>Review Ver.</b>	<b>Date</b>	<b>Correction List</b>	<b>Etc.</b>
Ver 1.0	2006.05.12	Establish	