



# NB-EVB User Guide Manual

LPWA Module

## **SIMCom Wireless Solutions Limited**

SIMCom Headquarters Building, Building 3, No. 289 Linhong  
Road, Changning District, Shanghai P.R. China

Tel: 86-21-31575100

[support@simcom.com](mailto:support@simcom.com)

[www.simcom.com](http://www.simcom.com)

<b>Document Title:</b>	NB-EVB User Guide Manual
<b>Version:</b>	V1.00
<b>Date:</b>	2023-02-17
<b>Status:</b>	Released

## GENERAL NOTES

SIMCOM OFFERS THIS INFORMATION AS A SERVICE TO ITS CUSTOMERS, TO SUPPORT APPLICATION AND ENGINEERING EFFORTS THAT USE THE PRODUCTS DESIGNED BY SIMCOM. THE INFORMATION PROVIDED IS BASED UPON REQUIREMENTS SPECIFICALLY PROVIDED TO SIMCOM BY THE CUSTOMERS. SIMCOM HAS NOT UNDERTAKEN ANY INDEPENDENT SEARCH FOR ADDITIONAL RELEVANT INFORMATION, INCLUDING ANY INFORMATION THAT MAY BE IN THE CUSTOMER'S POSSESSION. FURTHERMORE, SYSTEM VALIDATION OF THIS PRODUCT DESIGNED BY SIMCOM WITHIN A LARGER ELECTRONIC SYSTEM REMAINS THE RESPONSIBILITY OF THE CUSTOMER OR THE CUSTOMER'S SYSTEM INTEGRATOR. ALL SPECIFICATIONS SUPPLIED HEREIN ARE SUBJECT TO CHANGE.

## COPYRIGHT

THIS DOCUMENT CONTAINS PROPRIETARY TECHNICAL INFORMATION WHICH IS THE PROPERTY OF SIMCOM WIRELESS SOLUTIONS LIMITED. COPYING, TO OTHERS AND USING THIS DOCUMENT, ARE FORBIDDEN WITHOUT EXPRESS AUTHORITY BY SIMCOM. OFFENDERS ARE LIABLE TO THE PAYMENT OF INDEMNIFICATIONS. ALL RIGHTS RESERVED BY SIMCOM IN THE PROPRIETARY TECHNICAL INFORMATION, INCLUDING BUT NOT LIMITED TO REGISTRATION GRANTING OF A PATENT, A UTILITY MODEL OR DESIGN. ALL SPECIFICATION SUPPLIED HEREIN ARE SUBJECT TO CHANGE WITHOUT NOTICE AT ANY TIME.

### **SIMCom Wireless Solutions Limited**

SIMCom Headquarters Building, Building 3, No. 289 Linhong Road, Changning District, Shanghai P.R. China

Tel: +86 21 31575100

Email: [simcom@simcom.com](mailto:simcom@simcom.com)

### **For more information, please visit:**

<https://www.simcom.com/download/list-863-en.html>

### **For technical support, or to report documentation errors, please visit:**

<https://www.simcom.com/ask/> or email to: [support@simcom.com](mailto:support@simcom.com)

Copyright © 2023 SIMCom Wireless Solutions Limited All Rights Reserved.

## Version History

Date	Version	Description of change	Author
2023-02-17	1.00	Original	Xin Zhou

SIMCom  
Confidential

# Contents

<b>1. Introduction</b> .....	<b>10</b>
<b>2. General Overview</b> .....	<b>11</b>
2.1 Key Features .....	11
2.2 Top and Bottom Views of NB-EVB .....	13
2.3 NB-EVB Assessment kit .....	15
<b>3. Interface Applications</b> .....	<b>17</b>
3.1 Power supply Interface .....	17
3.1.1 Power supply .....	17
3.1.2 Power Supply Test Points .....	18
3.2 (U)SIM Interface .....	21
3.3 UART Interface .....	22
3.4 Status Indication LEDs .....	23
3.5 Switch and Button .....	25
3.6 Arduino Interface .....	26
3.6 Jumper Interface .....	28
3.7 Test point .....	32
<b>4. Operation Procedures Illustration</b> .....	<b>38</b>
4.1 Power on/off the Module .....	38
4.2 Driver Installation .....	38
4.2.1 USB-to-UART Driver Installation .....	38
4.3 Firmware Update .....	39
4.3.1 SIM7022 and E7025 software upgrades process .....	40
4.3.2 Y70XX series software upgrades process .....	43
4.3.3 H7035C software upgrades process .....	46
4.4 AT Command Communication .....	50
4.4.1 UART Serial Port Communication .....	50
<b>5. Current Consumption Test</b> .....	<b>52</b>
5.1 Preparation for Test .....	52
5.2 Current consumption test .....	52
<b>6. Appendix</b> .....	<b>54</b>
6.1 Related Documents .....	54
6.2 Terms and Abbreviations .....	55
6.3 Safety Caution .....	56

SIMCom  
Confidential

## Table Index

Table 1: Key Features .....	11
Table 2: The modules supported by NB-EVB .....	11
Table 3: The test point on the EVB .....	15
Table 4: EVB Assessment Kits .....	16
Table 5: Interface applications .....	17
Table 6: The power supply of the modules .....	20
Table 7: The pin definition of the (U)SIM card holder .....	22
Table 8: The definition of the Type-C USB interface (J103) .....	23
Table 9: The status indication LED lights .....	24
Table 10: Status indicated by LEDs .....	24
Table 11: Switch and Buttons .....	25
Table 12: The description of the Arduino interface .....	27
Table 13: Jumpers and toggle switches .....	28
Table 14: Jumpers J105 .....	30
Table 15: Jumpers J105 .....	32
Table 16: The description of the test point J106 .....	34
Table 17: The description of the test point J401 .....	34
Table 18: The description of the test point J402 .....	35
Table 19: The description of the test point FAST_TXD and FAST_RXD .....	37
Table 20: The CP2105 chip port .....	39
Table 21: The CH342F chip port .....	39
Table 22: UART data frame format .....	50
Table 23: The default baud rate of each module .....	50
Table 24: UART baud rate support .....	50
Table 25: UART baud rate operation .....	51
Table 26: Related Documents .....	54
Table 27: Terms and abbreviations .....	55
Table 28: Safety Caution .....	56

## Figure Index

Figure 1: The top view of NB-EVB .....	13
Figure 2: The bottom view of NB-EVB .....	14
Figure 3: NB-EVB Assessment Kits .....	16
Figure 4: The power supply block diagram .....	18
Figure 5: EVB power supply interface .....	18
Figure 6: Power supply reference design .....	19
Figure 7: Power supply test points (VBAT GND) .....	20
Figure 8: The (U)SIM reference design .....	21
Figure 9: The pin definition of the (U)SIM card holder (J301) .....	21
Figure 10: The reference design of USB to UART .....	22
Figure 11: The definition of the Type-C interface (J103) .....	23
Figure 12: The status indication LED lights (LED101, LED401, and LED402) .....	24
Figure 13: Switch and Buttons .....	25
Figure 14: Arduino interface on the EVB .....	26
Figure 15: Jumpers and toggle switches on the EVB .....	28
Figure 16: Jumpers J101 J102 and J507 .....	29
Figure 17: Jumper J105 .....	30
Figure 18: Jumper J208 and J209 .....	30

Figure 19: Use UART-to-USB function .....	31
Figure 20: Use UART-to-USB function .....	31
Figure 21: Switch J205 .....	32
Figure 22: The test points on the NB-EVB .....	33
Figure 23: The test point of the J106 .....	33
Figure 24: The test point of the J401 .....	34
Figure 25: The test point of the J402 .....	35
Figure 26: The test point of the FAST_TXD and FAST_RXD .....	36
Figure 27: The CP2105 chip port .....	38
Figure 28: The CH342F chip port .....	39
Figure 29: Enter force download mode .....	40
Figure 30: The interface of download tool .....	41
Figure 31: The configuration file of download tool .....	41
Figure 32: Choose the software .....	42
Figure 33: Choose the 'Erase' function .....	42
Figure 34: Click the 'Download' .....	43
Figure 35: Enter force download mode .....	43
Figure 36: Y7028 download tool .....	44
Figure 37: Select the firmware .....	44
Figure 38: Module begins to download .....	45
Figure 39: The module download is successful .....	45
Figure 40: Y7028 download tool .....	46
Figure 41: Set download baud rate .....	47



Figure 42: Choose serial port and select firmware path ..... 47

Figure 43: 'CCC' character appears ..... 48

Figure 44: Start to download .....49

Figure 45: Download succeeded ..... 49

Figure 46: The method of test current consumption ..... 52

SIMCom  
Confidential

## 1. Introduction

This document describes the interface and usage of the NB-EVB kit. With the help of this document, customers can quickly use the NB-EVB Kit.

SIMCom  
Confidential

## 2. General Overview

### 2.1 Key Features

The key features of NB-EVB are listed in the following table.

**Table 1: Key Features**

Feature	Implementation
Power supply	USB_VBUS: 5V
(U)SIM interface	(U)SIM card: 1.8V or 3.0V dual-voltage operation
UART interface	USB to UART interface
Status indication LEDs	Three status indication LEDs
Switch and buttons	One switch and two buttons
Arduino interface	One Arduino interface

The modules supported by EVB are listed in the following table.

**Table 2: The modules supported by NB-EVB**

Part Number	Module model
S2-109DC	8EC000-SIM7022_V1.01
S2-109DJ	8EC000-Y7025_V1.01
S2-10CA1	8EC000-Y7025H_V1.01
S2-109DV	8EC000-Y7012_V1.01
S2-109DQ	8EC000-Y7026_V1.01
S2-10B24	8EC000-Y7026_V1.02
S2-109D4	8EC000-E7025_V1.02

---

S2-10B2J	8EC000-E7025-L_V1.02
S2-109D9	8EC000-E7025_V2.01
S2-10AB1	8HC000-H7035C_V1.01

---

SIMCom  
Confidential

## 2.2 Top and Bottom Views of NB-EVB

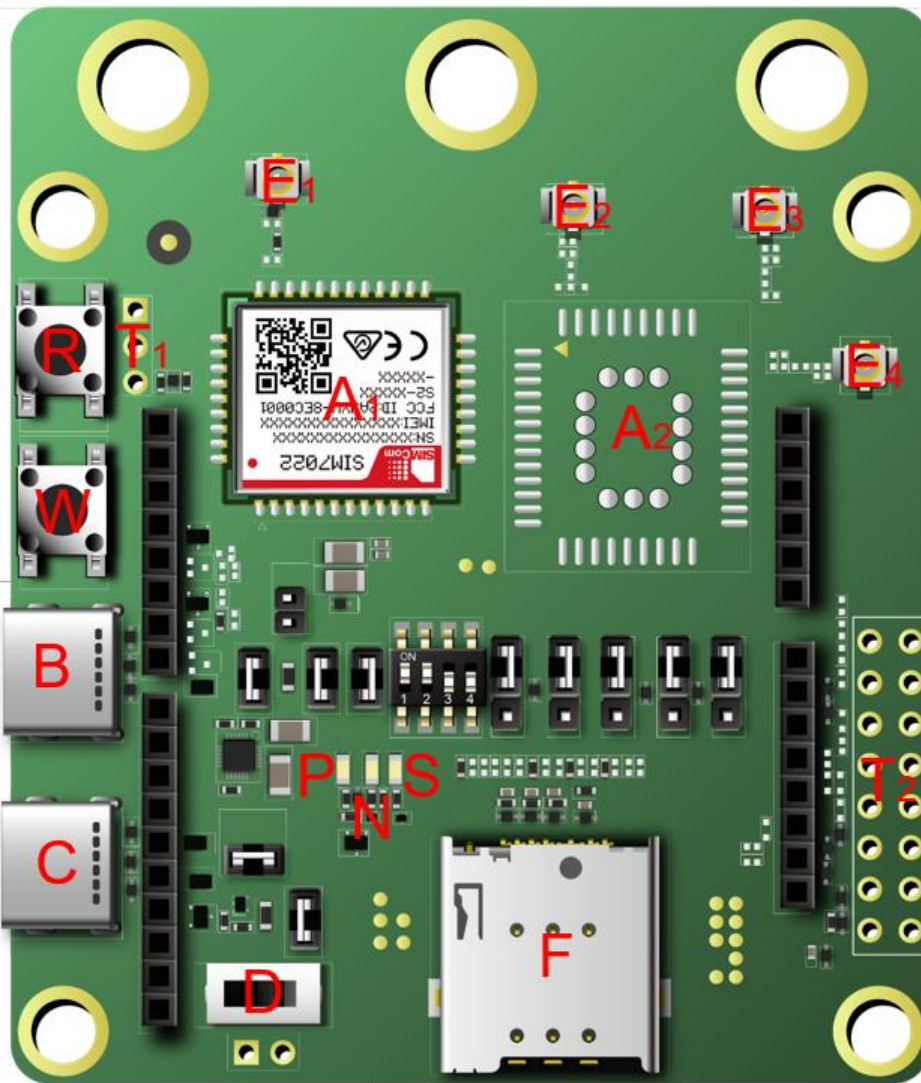

Figure 1: The top view of NB-EVB

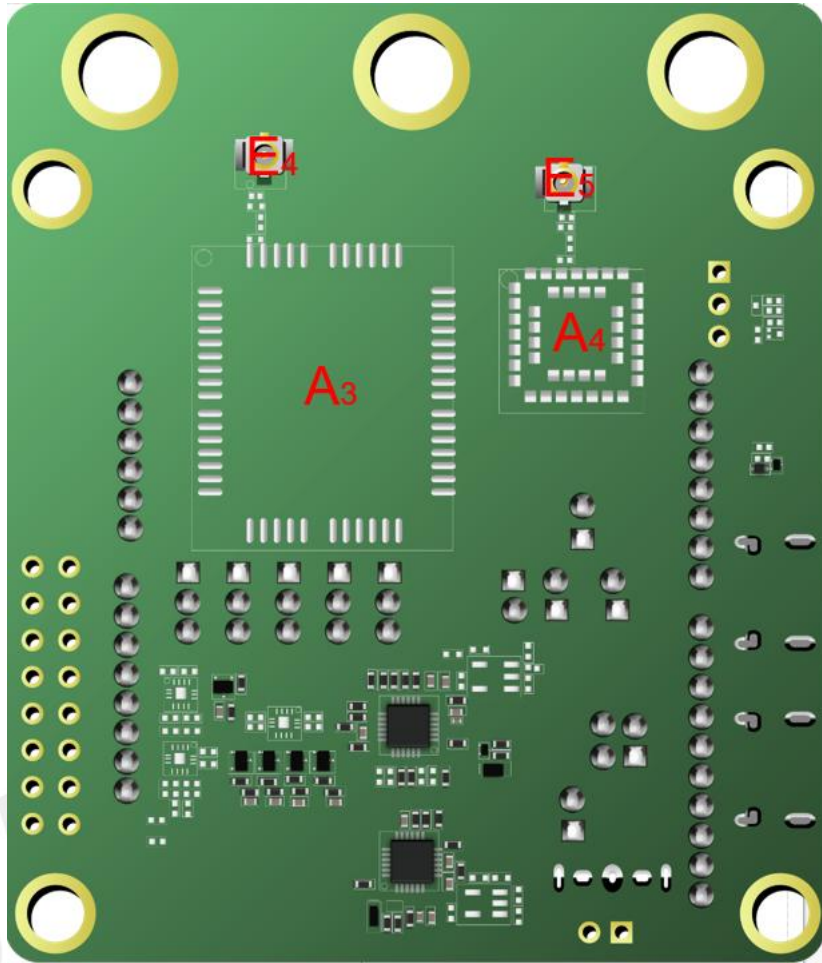

Figure 2: The bottom view of NB-EVB

**NOTE**

The figures above are the effect diagrams of the module, for reference only. Please refer to the actual product for appearance.

**Table 3: The test point on the EVB**

Attachment Label	Description
A <sub>1</sub> , A <sub>2</sub> , A <sub>3</sub> , A <sub>4</sub>	Module
B	Main UART, used for AT command
C	DBG UART, used for software debug and transmit log information
D	Power supply switch
E <sub>1</sub> , E <sub>2</sub> , E <sub>3</sub> , E <sub>4</sub> , E <sub>5</sub>	Main Antenna Connector
F	SIM card holder
P	Power supply indication LED
N	Network status indication LED
S	Operation status indication LED
R	RESET button
W	WAKEUP button
T <sub>1</sub> ,T <sub>2</sub>	Test points

**NOTE**

1. The modules supported by EVB do not support the hot swap function; please insert the SIM card into the “**F**” before the module is turned on, otherwise the SIM card will not be recognized successfully.

## 2.3 NB-EVB Assessment kit

NB-EVB assessment kits are listed as follows. Please confirm all accessories are complete.

- 1) NB-EVB board
- 2) Type-C USB cable
- 3) RF cable
- 4) GSM\WCDMA\LTE Antenna

NB-EVB assessment kits are shown in the following figure:

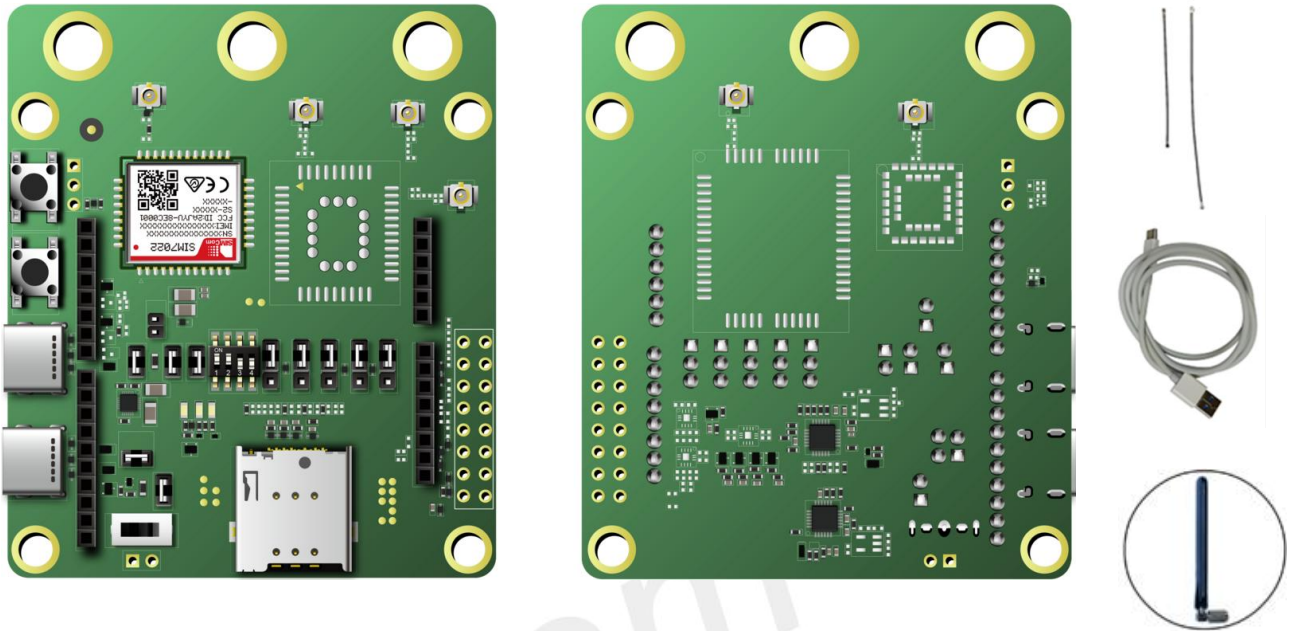

Figure 3: NB-EVB Assessment Kits

**NOTE**

1. The above EVB KIT only uses SIM7022 as an example, and the other modules use the same EVB kit, the only difference is the mounting of the modules on the EVB.

Table 4: EVB Assessment Kits

EVB Assessment kits	Description	Quantity
NB-EVB	EV board	1
GSM\WCDMA \LTE Antenna	GSM\WCDMA\LTE Antenna	1
RF cable	RF cable	1
Type-C USB cable	Type-C USB cable	1



## 3. Interface Applications

The interfaces of NB-EVB are listed as follows.

**Table 5: Interface applications**

Interface	Label	Description
(U)SIM	J301	(U)SIM card holder
UART	J103	J103 used for AT communication, data transmit.
	J104	J104 used for software debug and transmit log
LEDS	LED101	LED101: Power supply indication LED
	LED401	LED401: Network status indication LED
	LED402	LED402: Operation status indication LED
Switch	SW101	SW101: Power supply switch
Button	SW401	SW401: Reset button
	SW402	SW402: WAKEUP button
Arduino Interface	J405 J406 J407 J408	J405,J406,J407,J408 used for Arduino interface
Test point	J401 J402	J401 J402: test point

More details about the above functions are shown in the following chapter.

### 3.1 Power supply Interface

#### 3.1.1 Power supply

NB-EVB is powered by Type-C USB; power supply can be realized by inserting Type-C USB into J103 and J104.

The power supply block diagram of NB-EVB is shown in the following figure.

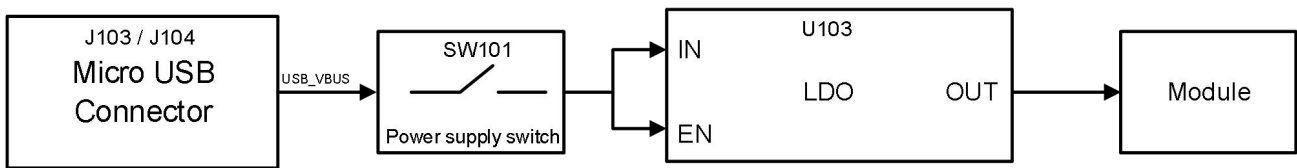

Figure 4: The power supply block diagram

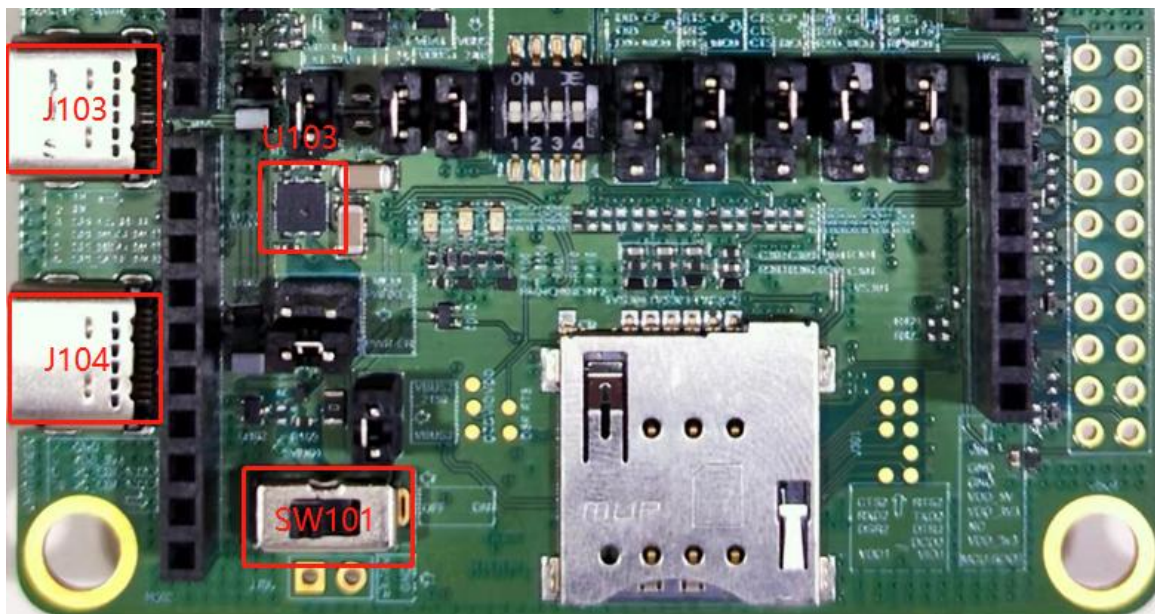
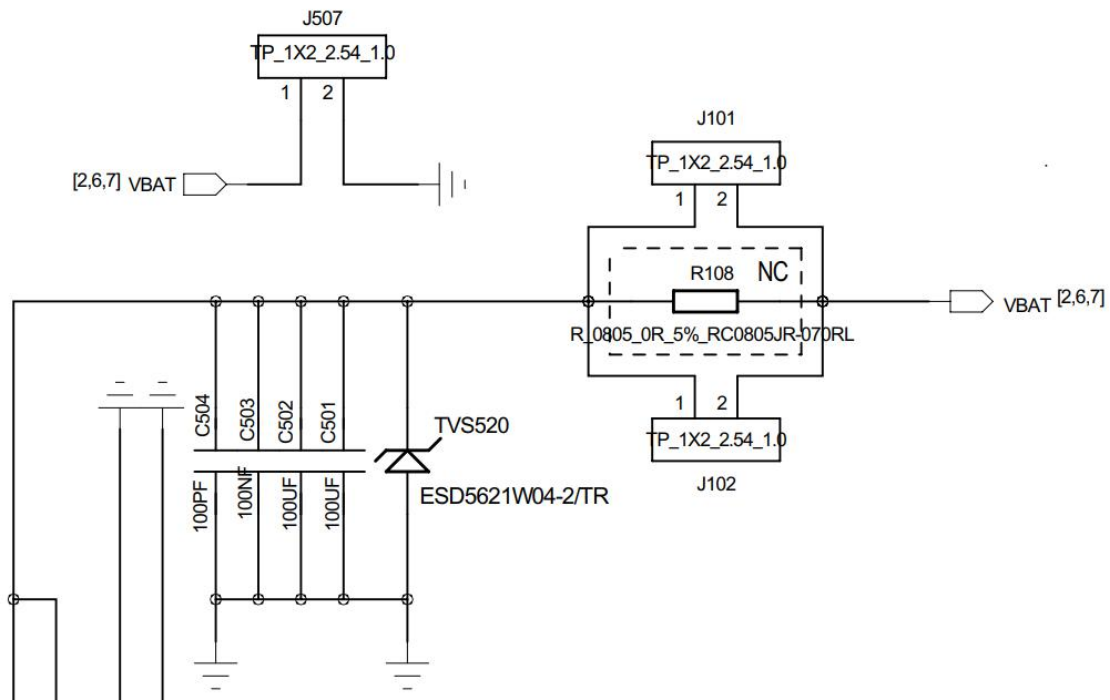

Figure 5: EVB power supply interface

### 3.1.2 Power Supply Test Points

The module power supply reference design is shown in the following figure.



**Figure 6: Power supply reference design**

The test points of VBAT and GND of the module are shown in the following figure. If the module needs separate power supply, J102 J101 jumper caps should be removed first, and then the external power supply should be applied from the test points of VBAT and GND, customer can connect dupont line from here to test current consumption.

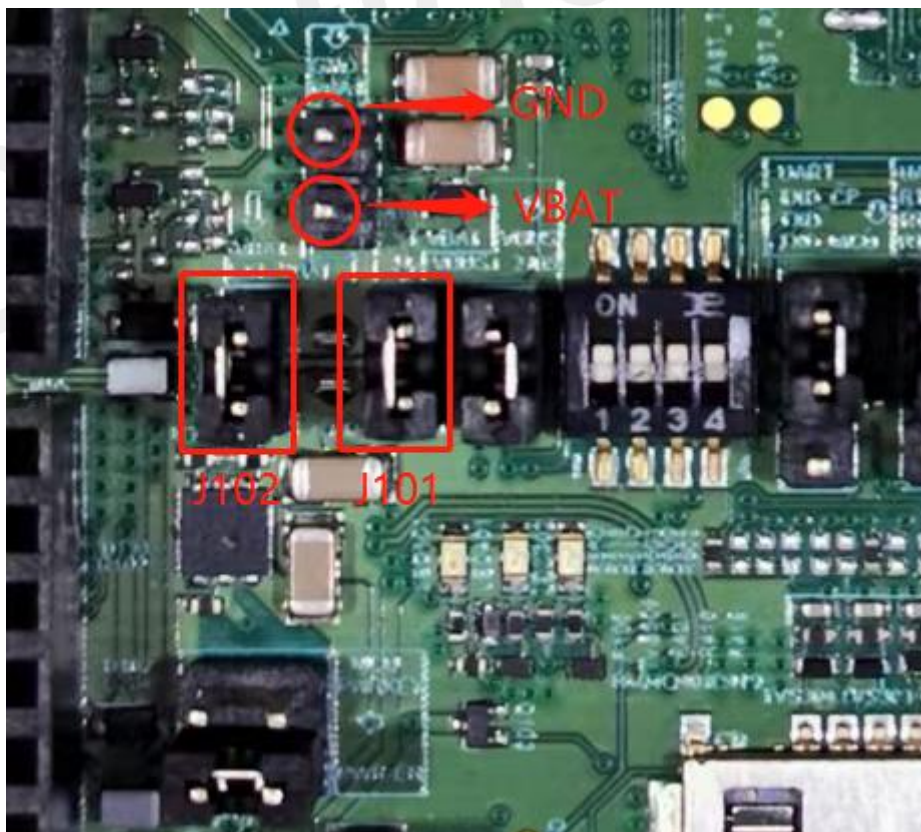

Figure 7: Power supply test points (VBAT GND)

Table 6: The power supply of the modules

Module	Power Supply Range	Recommend Voltage
SIM7022	2.2V~4.3V	3.3V
Y7025	2.2V~4.2V	3.3V
Y7025H	2.2V~4.2V	3.3V
Y7026	2.2V~4.2V	3.3V
Y7012	2.2V~4.2V	3.3V
E7025	2.2V~4.3V	3.3V
H7035C	2.1V~4.2V	3.6V

SIMCom  
Confidential

**NOTE**

1. Please ensure that the power supply voltage is within the power supply range when using different modules.

### 3.2 (U)SIM Interface

The modules supported by EVB do not support the hot swap function; please insert the SIM card before the module is turned on, otherwise the SIM card will not be recognized successfully.

The reference design of (U)SIM card interface is shown in the following figure.

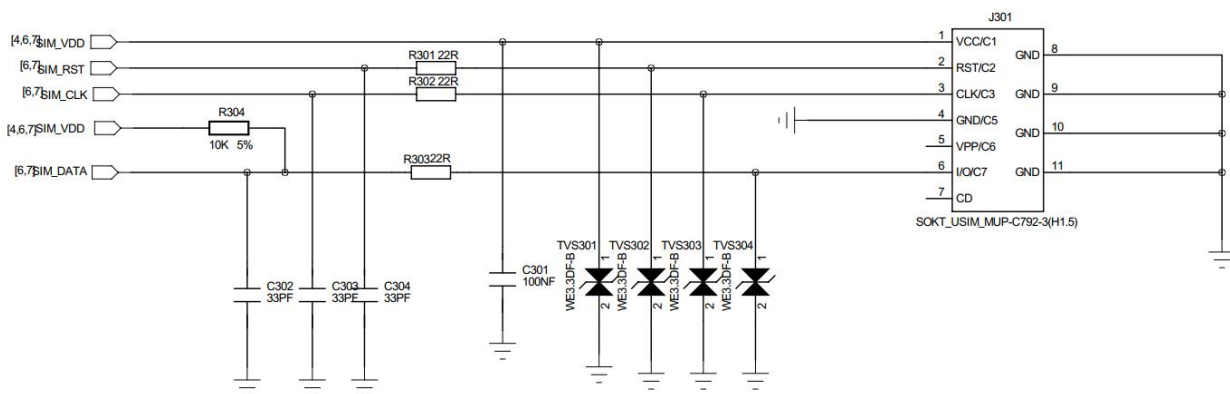

**Figure 8: The (U)SIM reference design**

The pin definition of the (U)SIM card holder is shown in the following figure.

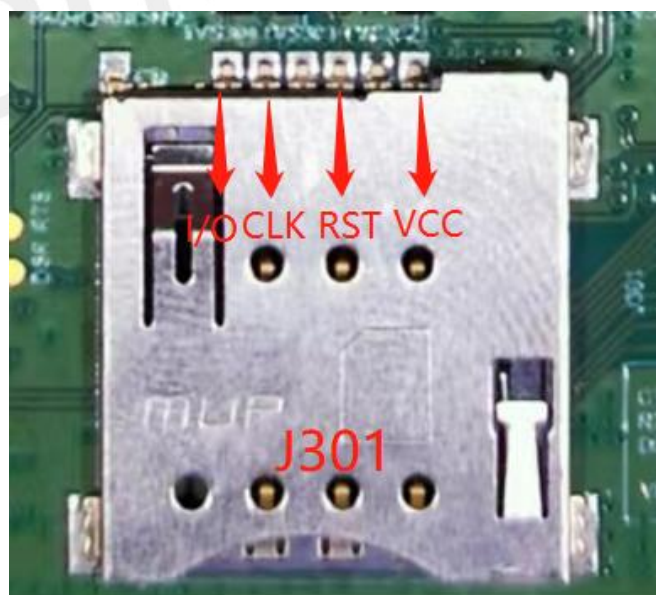

**Figure 9: The pin definition of the (U)SIM card holder (J301)**

Table 7: The pin definition of the (U)SIM card holder

PIN Num.	PIN Name	I/O	Description
1	VCC	O	(U)SIM card power supply
2	RST	O	(U)SIM card reset control
3	CLK	O	(U)SIM card clock
5	VPP	/	Float
6	I/O	IO	(U)SIM card data
7	CD	/	Float
4,8,9,10,11	GND		Ground

### 3.3 UART Interface

NB-EVB provides two USB to UART interfaces (J103 J104) including main UART port and debug UART port, J103 is used as main UART port for AT command and data transmission, J104 is used as debug UART port for software debug and log transmission.

The reference design of USB to UART is shown in the following figure.

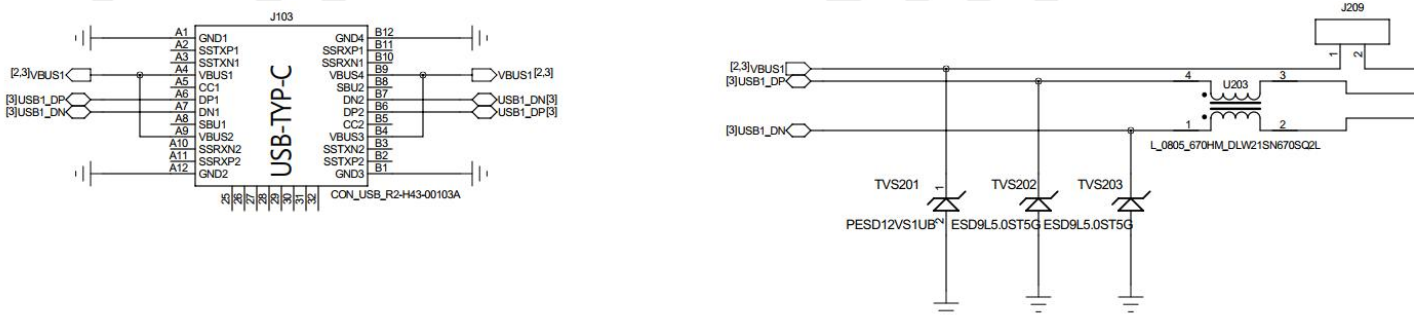

Figure 10: The reference design of USB to UART

The pin definition of the Type-C USB interface is shown in the following figure.



Figure 11: The definition of the Type-C interface (J103)

Table 8: The definition of the Type-C USB interface (J103)

PIN NUM.	PIN NAME	I/O	Description
1	GND	GND	Ground
2	SSRXP2	I	USB3.1 receive data positive
3	SSRXN2	I	USB3.1 receive data negative
4	VBUS	O	Power supply
5	SBU1	/	
6	DN1	I/O	Differential USB bi-directional data negative (USB to UART)
7	DP1	I/O	Differential USB bi-directional data positive (USB to UART)
8	CC1	O	CC detection
9	VBUS1	O	Power supply
10	SSTXN1	O	USB3.1 transmit data negative
11	SSTXP1	O	USB3.1 transmit data positive
12	GND		Ground

### 3.4 Status Indication LEDs

There are three status indication LED lights on the NB-EVB.

The three status indication LED lights are shown in the following figure.

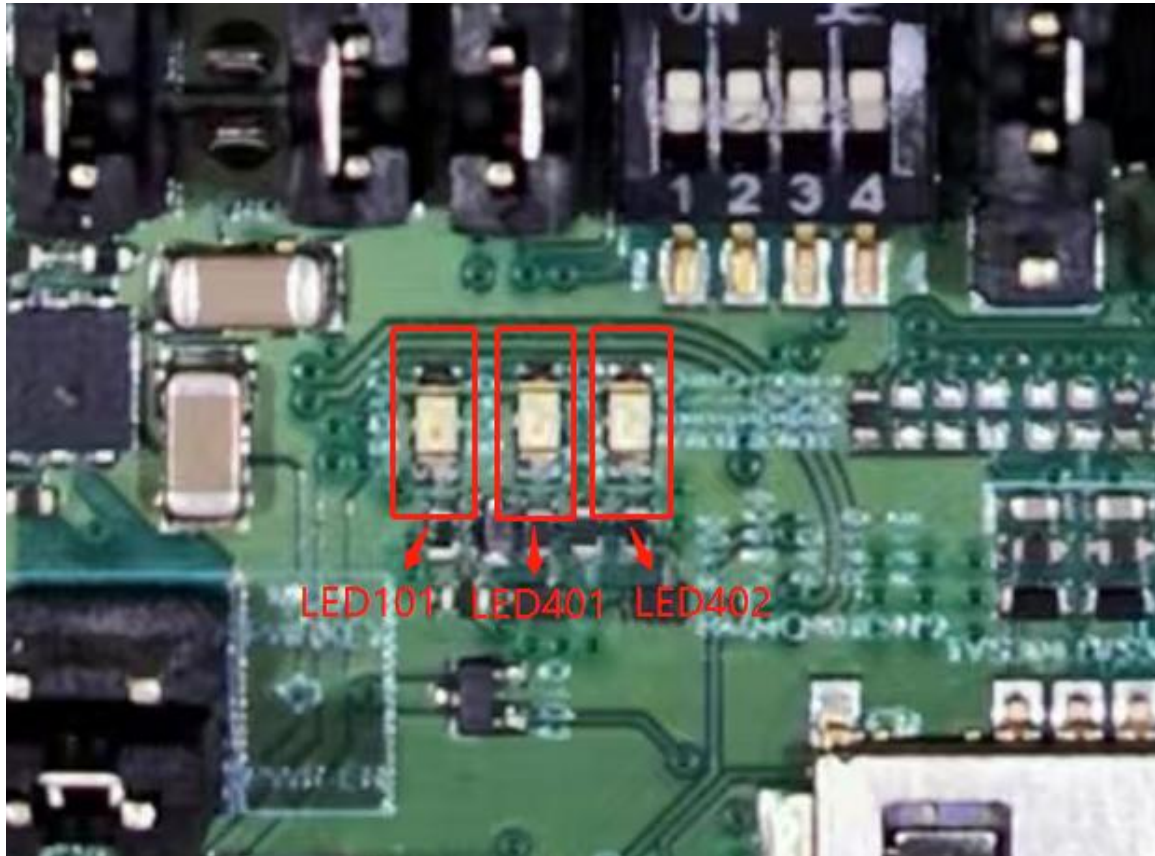

Figure 12: The status indication LED lights (LED101, LED401, and LED402)

Table 9: The status indication LED lights

LEDs name	LEDs color	Description
LED101	RED	VBAT power on indication LED
LED401	BLUE	Network status indication LED
LED402	BLUE	Operation status indication LED (Only SIM7022 support)

Table 10: Status indicated by LEDs

LEDs name	Status indicaton	Description
LED101	LED light on	EVB VABT power on
	LED light off	EVB VBAT power off
LED401	64ms ON, 800ms OFF	No registered network
	64ms ON, 2000ms OFF	Registered network (PS domain registration success)
	OFF	Power off or PSM mode
LED402	LED light on	Module power on and firmware ready
	LED light off	Module power off



### 3.5 Switch and Button

There are one switch (SW101) and two buttons (SW401 SW402) on the NB-EVB.



Figure 13: Switch and Buttons

Table 11: Switch and Buttons

Tag	NAME	Description
SW101	POWER_KEY	EVB power supply switch
SW401	RESET	Module reset button
SW402	WAKEUP	Module wakeup button

#### NOTE

1. The low level duration of the RESET or WAKEUP button determines whether the module performs the reset or wakeup function. For more details, please refer to the Hardware Design document of each

module.

### 3.6 Arduino Interface

There is an Arduino interface on the NB-EVB. Customers can use this interface to quickly and conveniently debug modules based on Arduino. The Arduino interface is shown in the following figure.

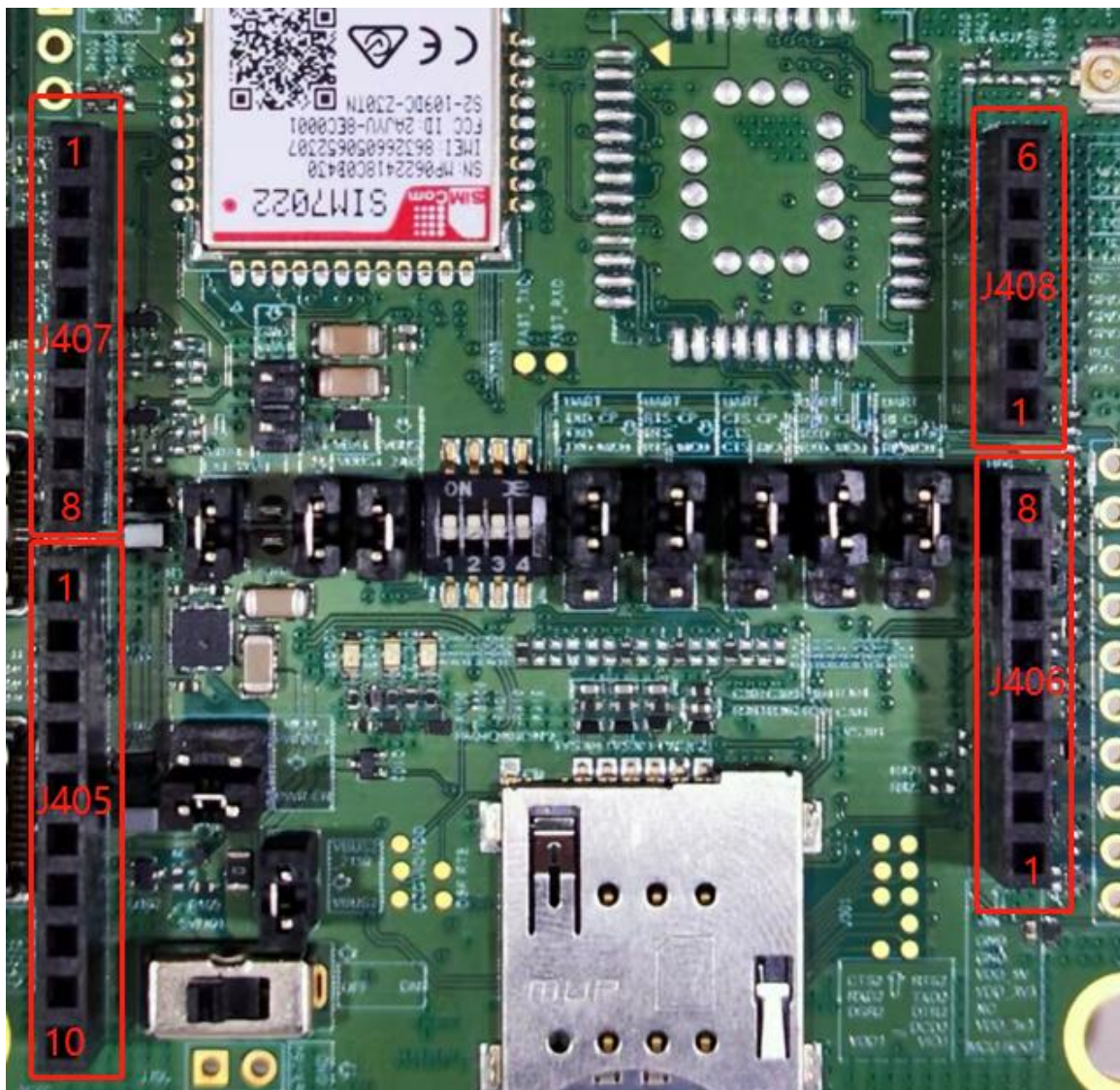

Figure 14: Arduino interface on the EVB

The detailed definition of the Arduino interface is shown in the following table.

**Table 12: The description of the Arduino interface**

Position	Test point	Signal	Description
J405	J405-1	NC	Not connect
	J405-2	NC	Not connect
	J405-3	MCU_SPI_CS	MCU SPI_CS signal
	J405-4	MCU_SPI_MOSI	MCU SPI_MOSI signal
	J405-5	MCU_SPI_MISO	MCU SPI_MISO signal
	J405-6	MCU_SPI_SCLK	MCU SPI_SCLK signal
	J405-7	GND	Ground
	J405-8	VDD_3V3	MCU external output voltage 3V3
	J405-9	MCU_I2C_SDA	MCU I2C_SDA signal
	J405-10	MCU_I2C_SCL	MCU I2C_SCL signal
J406	J406-1	MCU_BOOT	MCU boot control
	J406-2	MCU_IOREF	MCU GPIO reference voltage
	J406-3	NC	Not connect
	J406-4	VDD_3V3	MCU external output voltage 3V3
	J406-5	VDD_5V	MCU external output voltage 5V
	J406-6	GND	Ground
	J406-7	GND	Ground
	J406-8	NC	Not connect
J407	J407-1	MCU_RXD	MCU UART_RXD signal
	J407-2	MCU_TXD	MCU UART_TXD signal
	J407-3	MCU_RTS	MCU UART_RTS signal
	J407-4	MCU_CTS	MCU UART_CTS signal
	J407-5	WAKEUP	MCU wakeup the module signal
	J407-6	MCU_RI	MCU UART_RI signal
	J407-7	RESET	MCU reset the module signal
	J407-8	PWRKEY	MCU control the module power on/off
J408	J408-1	NC	Not connect
	J408-2	NC	Not connect
	J408-3	NC	Not connect
	J408-4	NC	Not connect
	J408-5	NC	Not connect
	J408-6	NC	Not connect

### 3.6 Jumper Interface

It mainly describes the interface with jumper selection or switch status. Please check the jumper selection and switch status according to the actual situation during usage.

There are eleven group jumpers and one toggle switch on the NB-EVB, the jumpers and toggle switches are shown in the following figure.

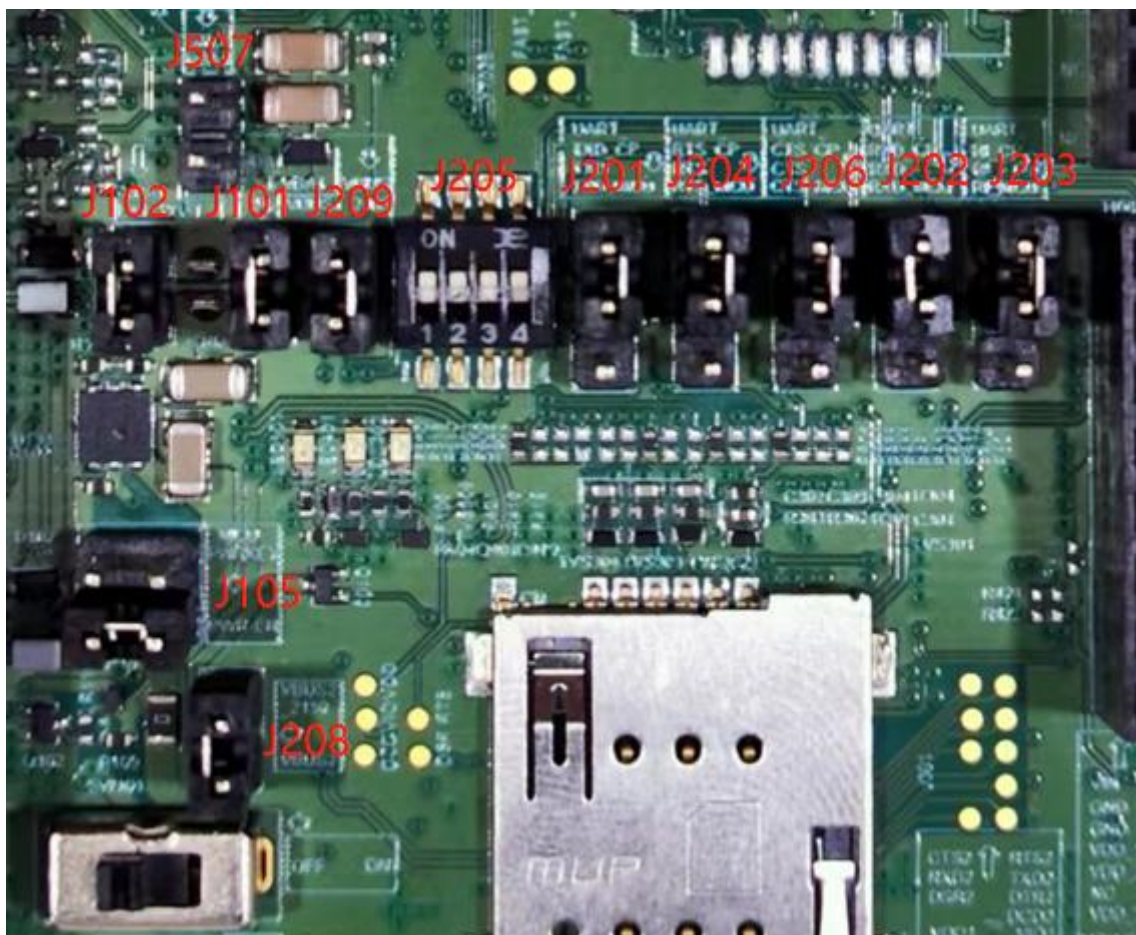

Figure 15: Jumpers and toggle switches on the EVB

Table 13: Jumpers and toggle switches

Position	Function Description
J101	VBAT power supply
J102	VBAT power supply
J105	Module power supply enable switch selection
J201	Module UART_TXD channel selection

J202	Module UART_RXD channel selection
J203	Module UART_RI channel selection
J204	Module UART_RTS channel selection
J205	Module DBG_UART, UART_DCD and UART_DTR channel selection
J206	Module UART_CTS channel selection
J208	The switch of CH342F VBUS
J209	The switch of CP2105 VBUS
J507	The test point of VBAT and GND

- 1) Position J101 and J102 is the main power supply jumper for EVB, and J507 is the test point of VBAT and GND. Customer can remove J101 and J102 and supply power from J105 for module current consumption test.

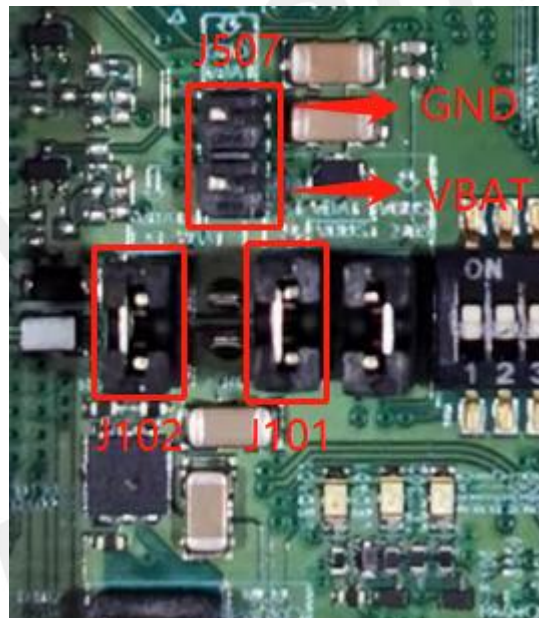

**Figure 16: Jumpers J101 J102 and J507**

- 2) Position J105 is the module power supply enable selection jumper, if choosing the J105-2, the power enable pin of EVB will be pulled up by default after power-on. If choosing the J501-1, the power on/off function of the module can be controlled by MCU through the Arduino interface.

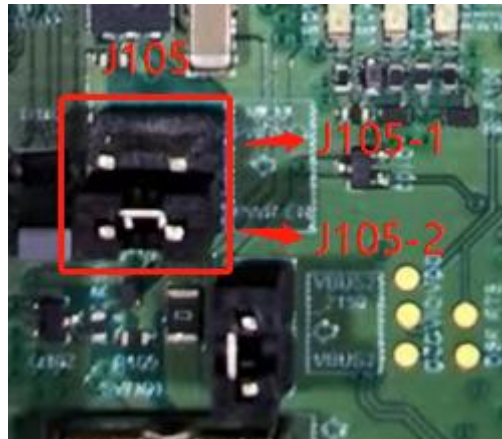

Figure 17: Jumper J105

Table 14: Jumpers J105

Position	Test Point	Function Description
J105	J105-1	Module can be controlled by MCU through the Arduino interface
	J105-2	Module power up directly

- 3) Position J208 and J209 are the power supply switches of USB-to-UART chip; jumper J208 can control the CH342F VBUS, if the jumper is removed, CH342F (DBG\_UART) will not work, jumper J209 also has the same function, if the J209 is removed, CP2105 (UART1) will not work. Customer can remove J208 and J209 for module current consumption test.

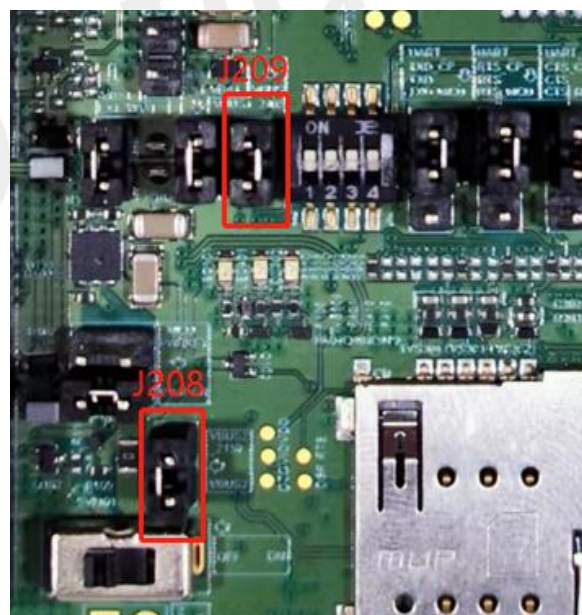
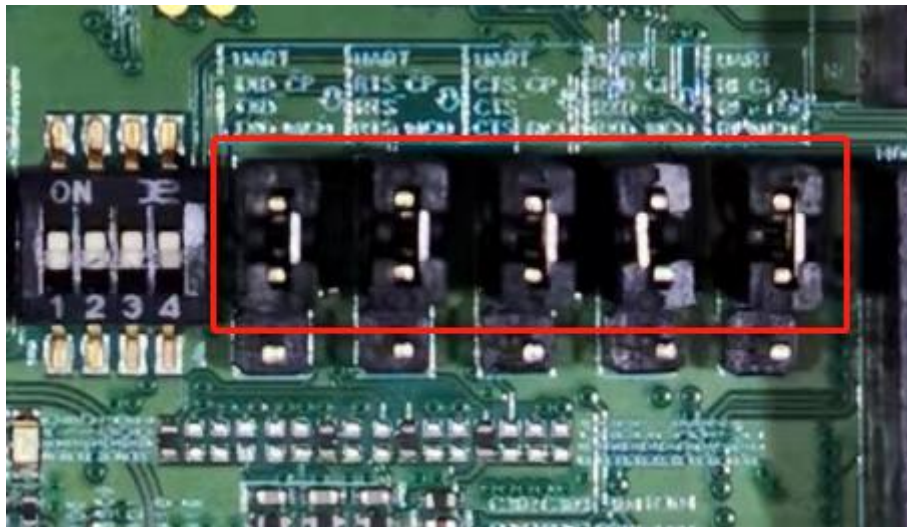

Figure 18: Jumper J208 and J209

- 4) Position J201 J202 J203 J204 and J206 are the UART function selection jumpers, customers can

change the communication mode of UART by selecting the connection mode.  
If customers want to use USB-to-UART function, please ensure the jumpers are connected as follows.



**Figure 19: Use UART-to-USB function**

And then, if customers want to verify the communication function between MCU and module through the Arduino interface, please ensure the jumpers are connected as follows.

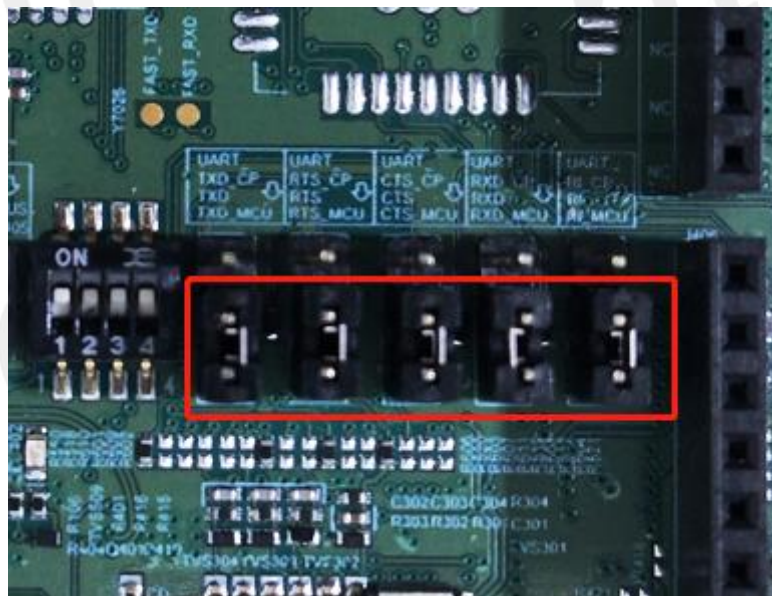

**Figure 20: Use UART-to-USB function**

- 5) Position J205 is the DBG\_UART, UART\_RI and UART\_DCD function selection switch; customers can choose whether to use these functions by pulling the J205 to on/off. It is strongly recommended that the customers turn the switch to OFF when testing current consumption.

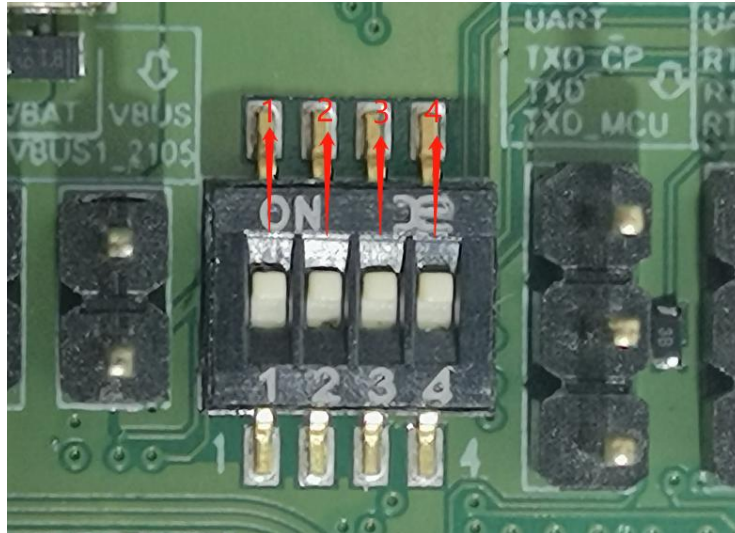

Figure 21: Switch J205

Table 15: Jumpers J105

Position	Switch Point	Signal	Description
J205	J205-1	UART_DCD	UART carrier detect
	J205-2	DBG_TXD	Customers can view the log information through the debug serial port for software debugging.
	J205-3	DBG_RXD	
	J205-4	UART_DTR	UART DTE get ready

### 3.7 Test point

There are four groups of test points on the NB-EVB. The test points are shown in the following figure.



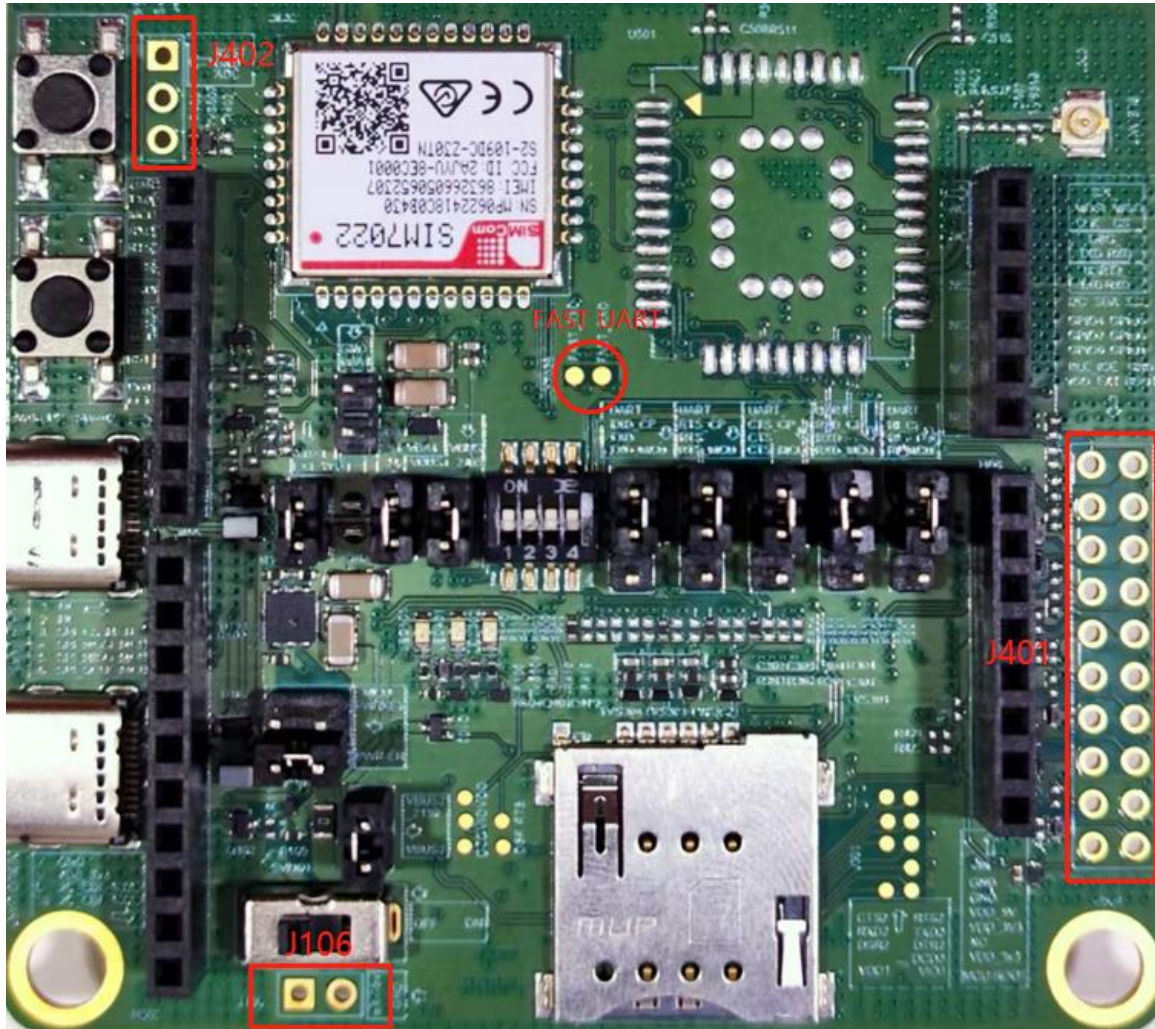

Figure 22: The test points on the NB-EVB

The pin definition of the J106 is shown in the following figure.

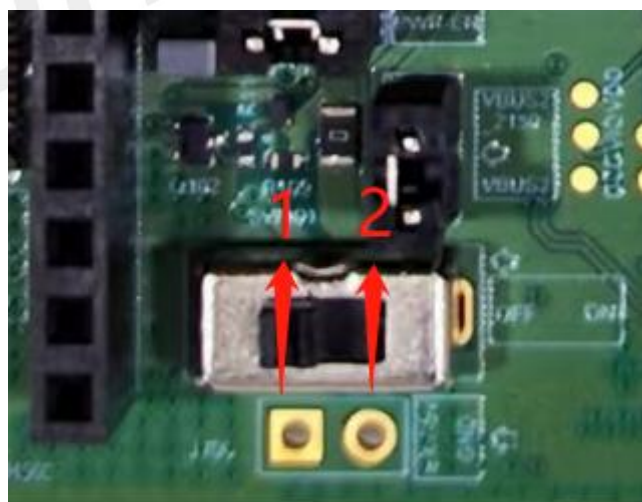

Figure 23: The test point of the J106

Table 16: The description of the test point J106

Position	Test point	Signal	Description
J106	J106_PIN1	EXT_5V	Test point of the 5V input voltage
	J106_PIN2	GND	Ground

The pin define of the J401 is shown as in the following figure.

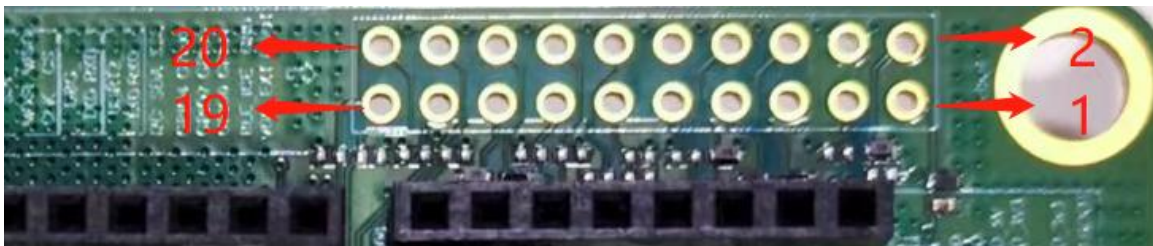

Figure 24: The test point of the J401

Table 17: The description of the test point J401

Position	Pin no.	Pin name	Module signal
J401	J401_PIN1	VDD_EXT	Module LDO power output
	J401_PIN2	BOOT	Download control pin
	J401_PIN3	BLE_ICE	Y7025H BLE firmware download
	J401_PIN4	GND	Ground
	J401_PIN5	GPIO0	General-purpose input/output
	J401_PIN6	GPIO1	General-purpose input/output
	J401_PIN7	GPIO2	General-purpose input/output
	J401_PIN8	GPIO3	General-purpose input/output
	J401_PIN9	GPIO4	General-purpose input/output
	J401_PIN10	GPIO5	General-purpose input/output
	J401_PIN11	I2C_SDA	I2C data input/output
	J401_PIN12	I2C_SCL	I2C clock output
	J401_PIN13	UART2_TXD	UART2 transmit Data
	J401_PIN14	UART2_RXD	UART2 receive Data
	J401_PIN15	DBG_TXD	DBG_UART transmit Data

J401_PIN16	DBG_RXD	DBG_UART receive Data
J401_PIN17	SPI_SCLK	Bus clock output
J401_PIN18	SPI_CS	Chip Select
J401_PIN19	SPI_MOSI	Main Controller DATA output
J401_PIN20	SPI_MISO	Main Controller DATA input

The pin define of the **J402** is shown as in the following figure.

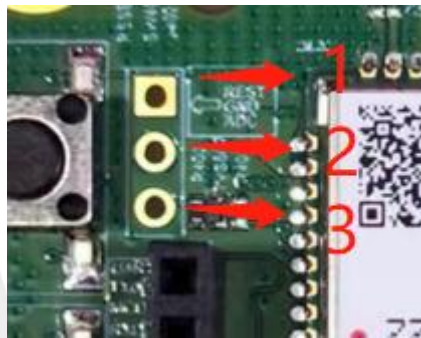

Figure 25: The test point of the **J402**

Table 18: The description of the test point **J402**

Position	Test point	Signal	Description
<b>J402</b>	J402_PIN1	RESET	The reset test point of module
	J402_PIN2	GND	Ground
	J402_PIN3	ADC	ADC interface

The pin define of the **FAST UART** is shown as in the following figure.



Figure 26: The test point of the **FAST\_TXD** and **FAST\_RXD**

SIMCom  
Confidential

**Table 19: The description of the test point **FAST\_TXD** and **FAST\_RXD****

Test point	Signal	Description
FAST_TXD	Y7026_FAST_TXD	These test points only be used for Y7026 download
FAST_RXD	Y7026_FAST_RXD	

**NOTE**

1. For more details of each pin of the module, please refer to each module's Hardware Design document.

SIMCom  
Confidential

## 4. Operation Procedures Illustration

### 4.1 Power on/off the Module

The module power on procedure is shown as following:

- (1) Insert Type-C USB into USB connectors J103 and J104.
- (2) Pull SW101 to power ON state, and the LED101, LED401 and LED402 will be lighted.
- (3) If the module is successfully registered in the network, the LED401 will flash slowly, otherwise, the LED401 will keep flashing all the time.

The module power off procedure is shown as following:

Power off the module by AT command, when the module is in power on status, by inputting AT command, after the module saving the data and the module will be powered off automatically and LED401 will be extinguished. Then pull the SW101 to off state. About the AT command, please refer to each module's AT command manual for more details.

### 4.2 Driver Installation

#### 4.2.1 USB-to-UART Driver Installation

NB-EVB board has two Type-USB interfaces. It is the USB to UART interfaces, one is CP2105 chip and the other is CH342F chip.

The customers can get CP2105 chip driver from the following link.

<https://www.silabs.com/products/development-tools/software/usb-to-uart-bridge-vcp-drivers>

After installing the driver correctly, you can see the following virtual USB port, COM30/COM29 (The example of port number).

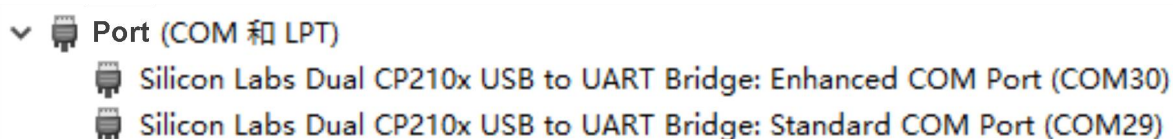

Figure 27: The CP2105 chip port

**Table 20: The CP2105 chip port**

Interface	Port num.	Module serial port	Remark
ECI	COM30	Enhance UART	Used for AT command, data transmission
SCI	COM29	Standard UART	/

The customers can get CH342F chip driver from the following link.

[https://www.wch.cn/downloads/CH343SER\\_EXE.html](https://www.wch.cn/downloads/CH343SER_EXE.html)

After installing the driver correctly, you can see the following virtual USB port, COM130/COM129 (The example of port number).

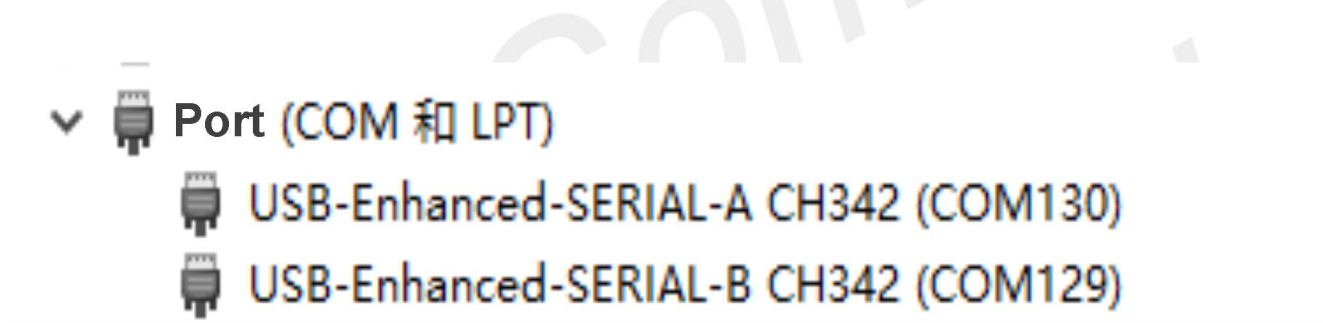

**Figure 28: The CH342F chip port**

**Table 21: The CH342F chip port**

Interface	Port num.	Module serial port	Remark
SERIAL-A	COM130	/	/
SERIAL-B	COM129	DEBUG_UART	Used for software debug and log transmission

## 4.3 Firmware Update

The firmware update process of the each module is as follows.

Before updating the firmware, please contact the SIMCom technical support team and the supplier to obtain the correct firmware upgrade file.

### 4.3.1 SIM7022 and E7025 software upgrades process

(1) Insert Type-C USB into the USB connector(J103), **pull down** the BOOT test point to the GND, then pull the SW101 to power ON state, the module will power on and enter force download mode.

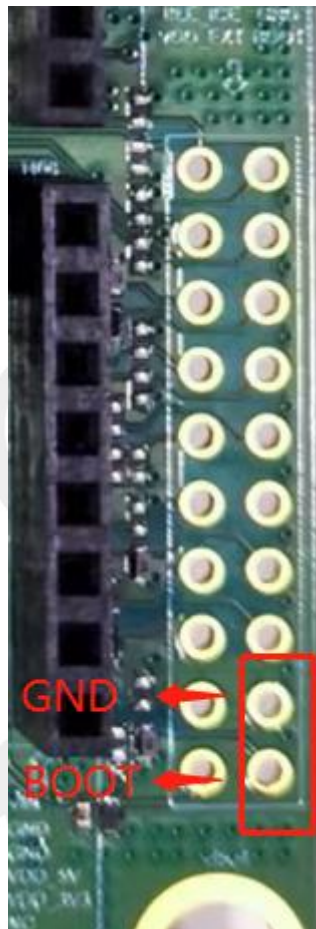

**Figure 29: Enter force download mode**

(2) Open the download tool, make sure the module connecting the download tool success, configure the tool parameters.



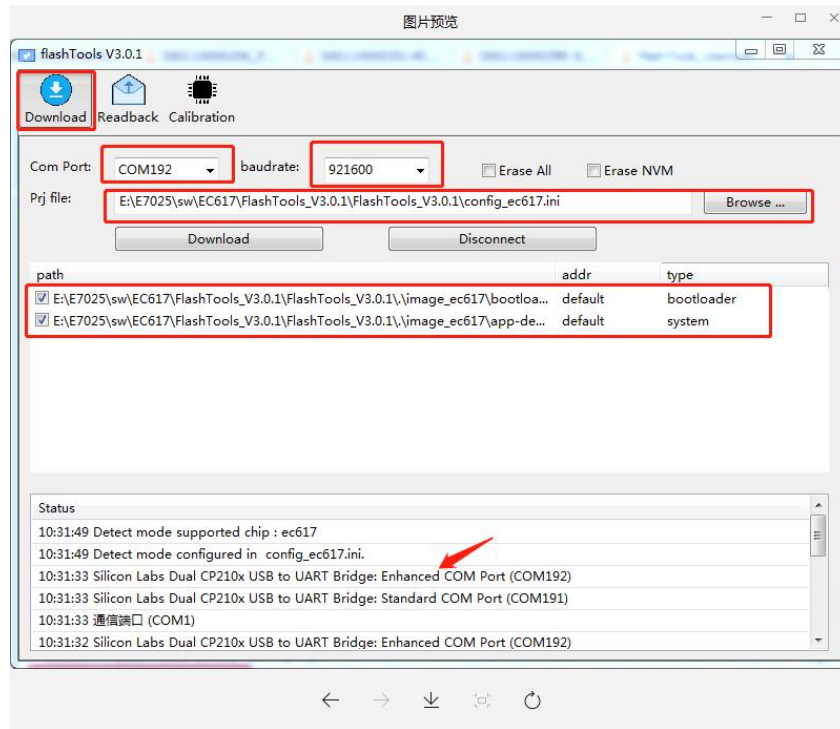

**Figure 30: The interface of download tool**

- (1) COM Port: Enhanced COM Port
- (2) Baud rate: 921600bps (default)
- (3) Project file: Select the configuration file 'config.ini' that comes with the download tool. Choose 'config\_ec616.ini' for the module SIM7022, and choose 'config\_ec617.ini' for the module E7025 .

名称	修改日期	类型	大小
image_ec616	2021/1/19 10:23	文件夹	
image_ec617	2021/1/19 10:23	文件夹	
agentboot.bin	2020/3/31 16:29	BIN 文件	27 KB
cfg.digest	2020/3/31 19:44	DIGEST 文件	1 KB
config_ec616	2020/3/31 16:29	配置设置	1 KB
config_ec617	2020/3/31 19:43	配置设置	1 KB
config_ec617.ini.bak	2020/3/31 18:58	BAK 文件	1 KB
FlashTools	2020/3/31 19:41	应用程序	13,436 KB
FlashTools_UserGuide_chs	2020/3/31 19:14	Foxit Reader PD...	2,330 KB
format.json	2020/3/31 16:29	JSON 文件	1 KB
littlefs_pc	2020/3/31 16:29	应用程序	25 KB
logging.conf	2020/3/31 16:29	CONF 文件	1 KB
logging_output	2020/3/31 19:44	文本文件	175 KB
Release_Note_FlashTools	2020/3/31 16:29	文本文件	1 KB
tmp.bin	2020/3/31 18:28	BIN 文件	40 KB
Tmp_config	2020/3/31 19:44	配置设置	1 KB
Tmptable.bin	2020/3/31 19:44	BIN 文件	1 KB

**Figure 31: The configuration file of download tool**

- (4) Path: In the 'bootloader' and 'system' files, select the software version provided by SIMCOM. Right-click and select "Edit item" to operate.

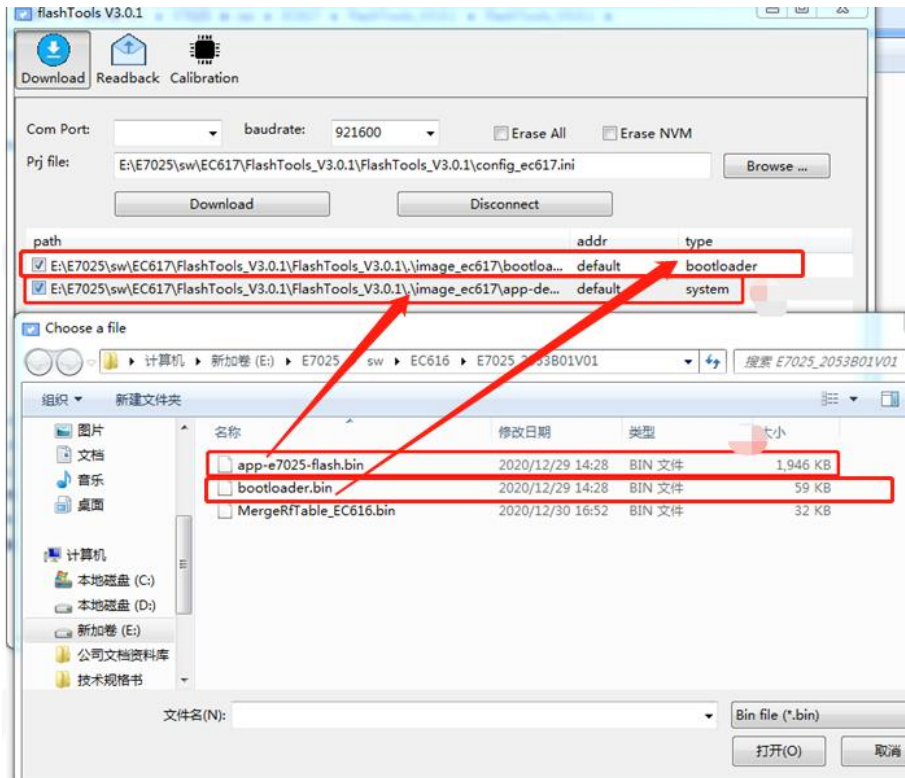

**Figure 32: Choose the software**

(5) If the users want to erase the entire flash, please check the 'Erase All' option box in the interface. If users only want to erase NVM files, please check the 'Erase NVM' option box in the interface. (It is strongly recommended that customers do not click "Erase all" and "Erase NVM")

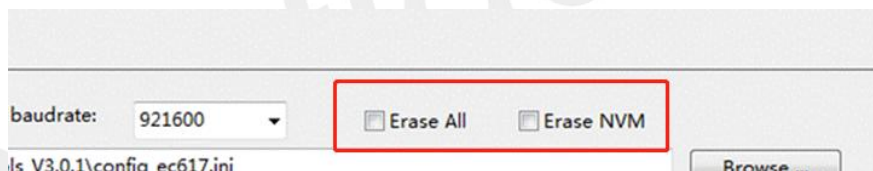

**Figure 33: Choose the 'Erase' function**

(6) Users can click the 'Download' button to start the download, and users can check the download status through the status area on the interface.

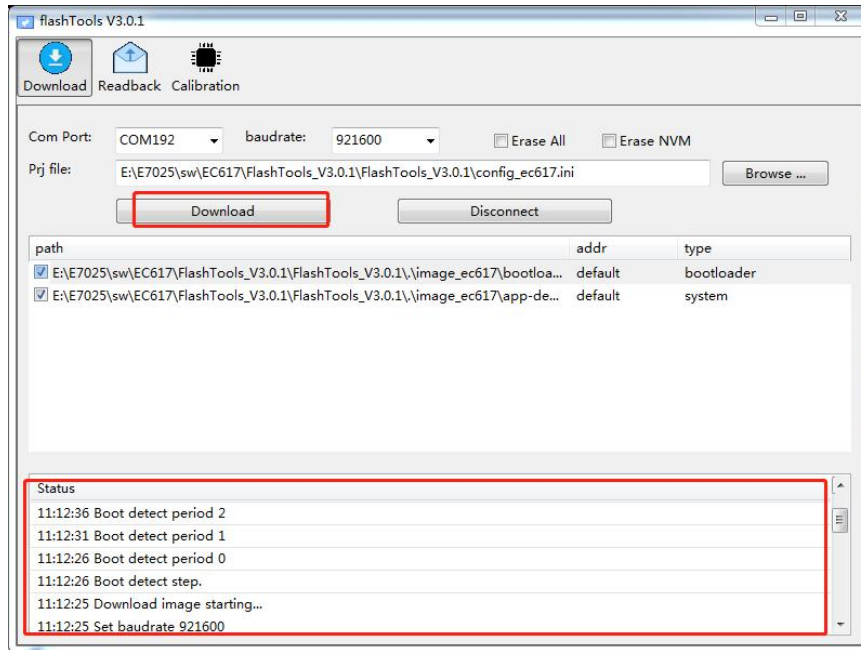

**Figure 34: Click the 'Download'**

After clicking the Download button on the download tool, the tool will perform 3 times Boot detect, and the module must be reset before the last Boot detect is over.

After resetting the module before the end of the tool monitoring, the tool will download the code.

#### 4.3.2 Y70XX series software upgrades process

- (1) Insert Type-C USB into the USB connector(J103), pull up the BOOT test point to the VEXT, then pull the SW101 to power ON state, the module will power on and enter force download mode.

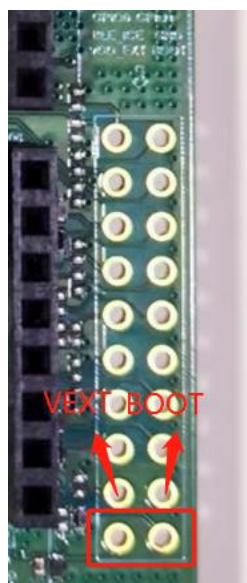

**Figure 35: Enter force download mode**

(2) Open the download tool, the interface is shown as follows.

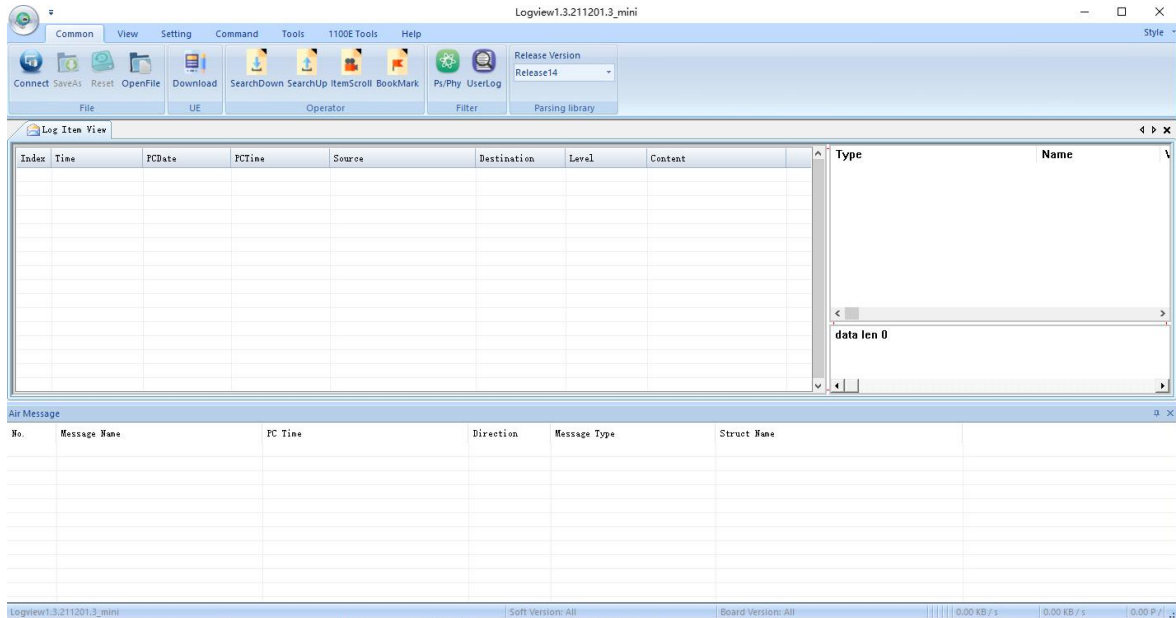

Figure 36: Y7028 download tool

(3) Make sure the module connecting the download tool successfully, click Download and choose Enhanced Port, then select the software document.

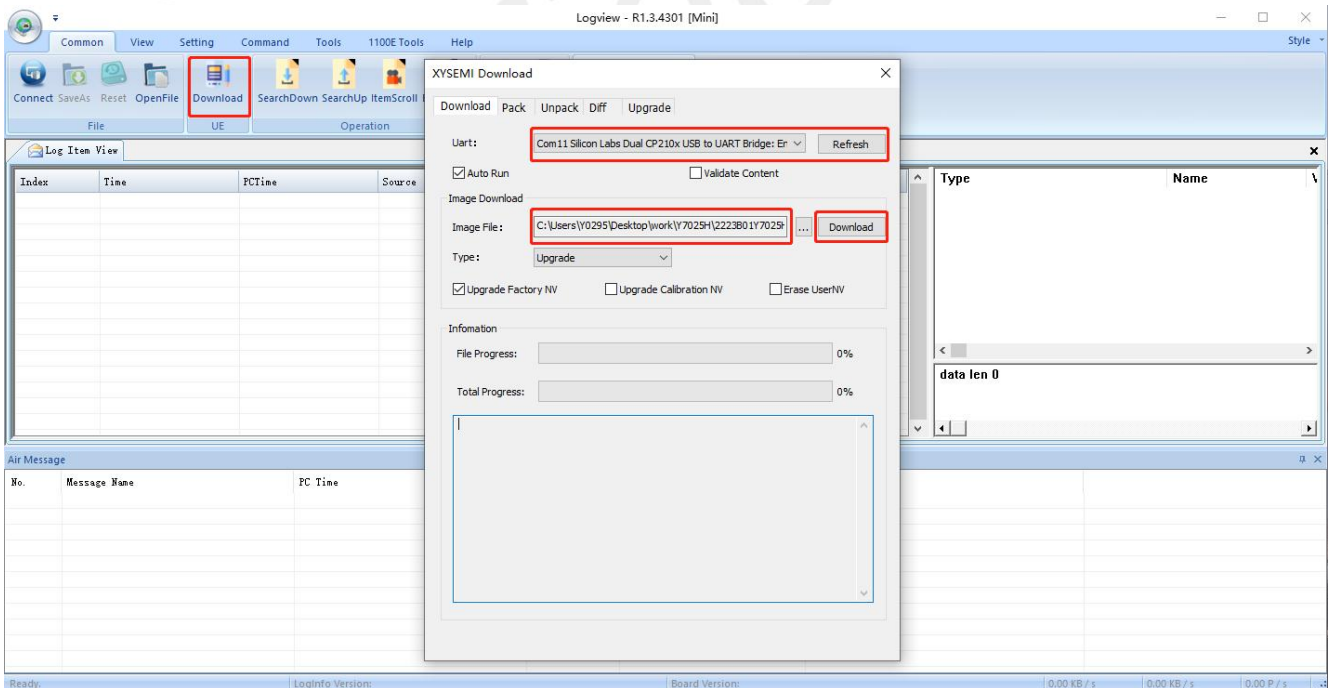

Figure 37: Select the firmware

(4) Click the 'Start' button, the module will start to download.

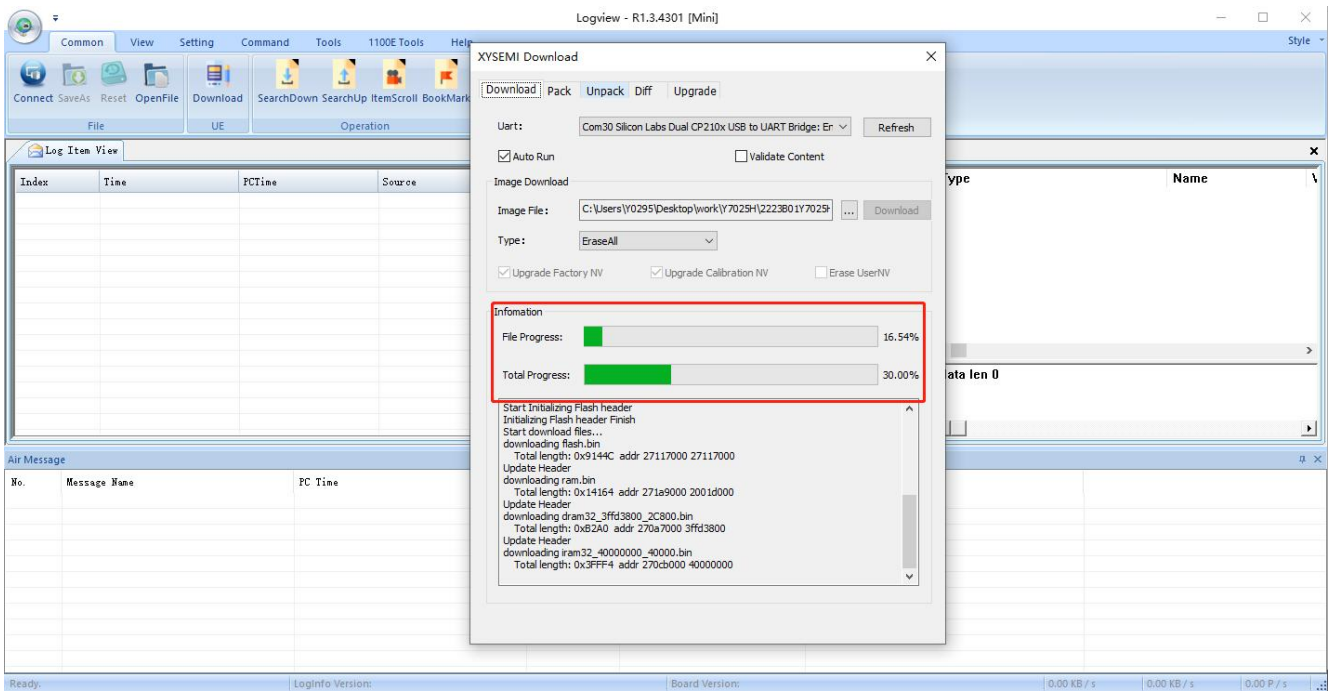

Figure 38: Module begins to download

(5) Download success.

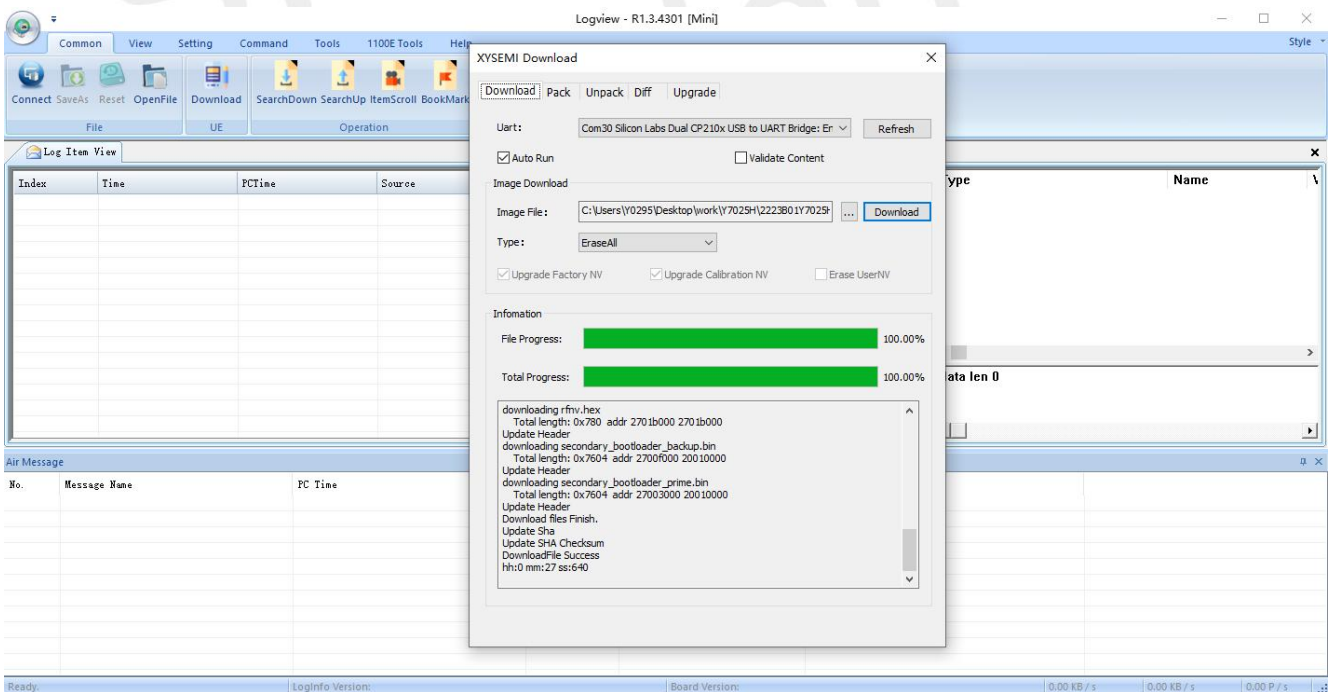
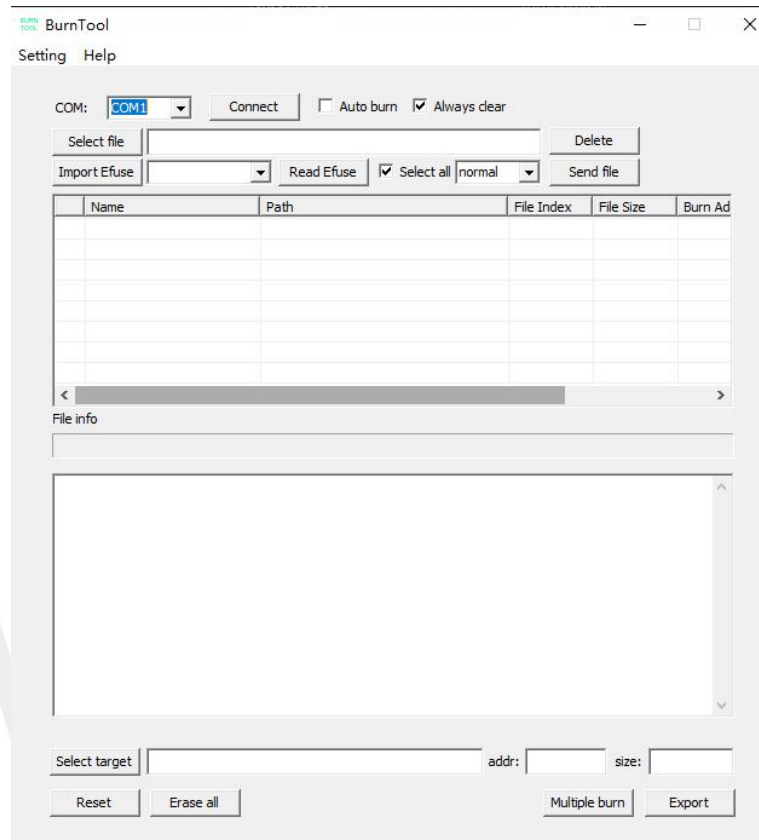

Figure 39: The module download is successful

(6) The module needs to be powered on again after the update is successful.

### 4.3.3 H7035C software upgrades process

(1) Insert Type-C USB into the USB connector (J104), and open the download tool, the interface is shown as follows.



**Figure 40: Y7028 download tool**

(2) Click the 'Setting' button, select Settings, and set the download baud rate in 'Baud'. At present, the highest EVB download rate can support 3Mbps.

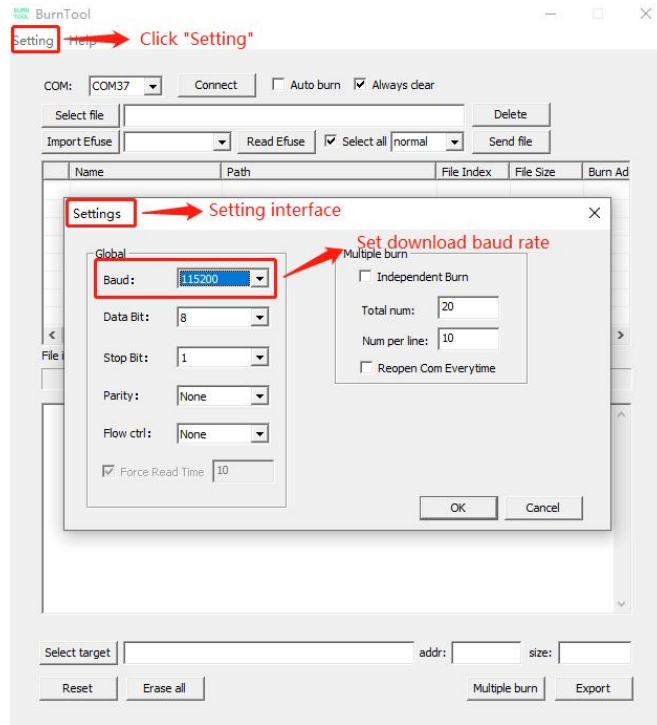

**Figure 41: Set download baud rate**

(3) Select the 'DBG\_UART' serial port, click 'Select file' button to search the firmware path, check 'Select all' button to ensure that each item in the software is checked, and click the menu at 'normal' button according to the update requirements to select the update method.

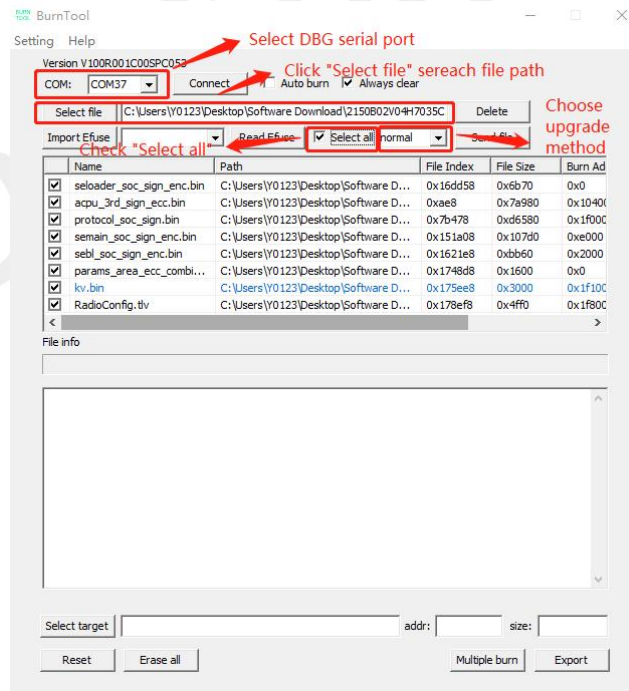

**Figure 42: Choose serial port and select firmware path**

(4) Click the connect button, and then press the reset button SW401 on the EVB, and the 'CCC' character will appear on the download interface.

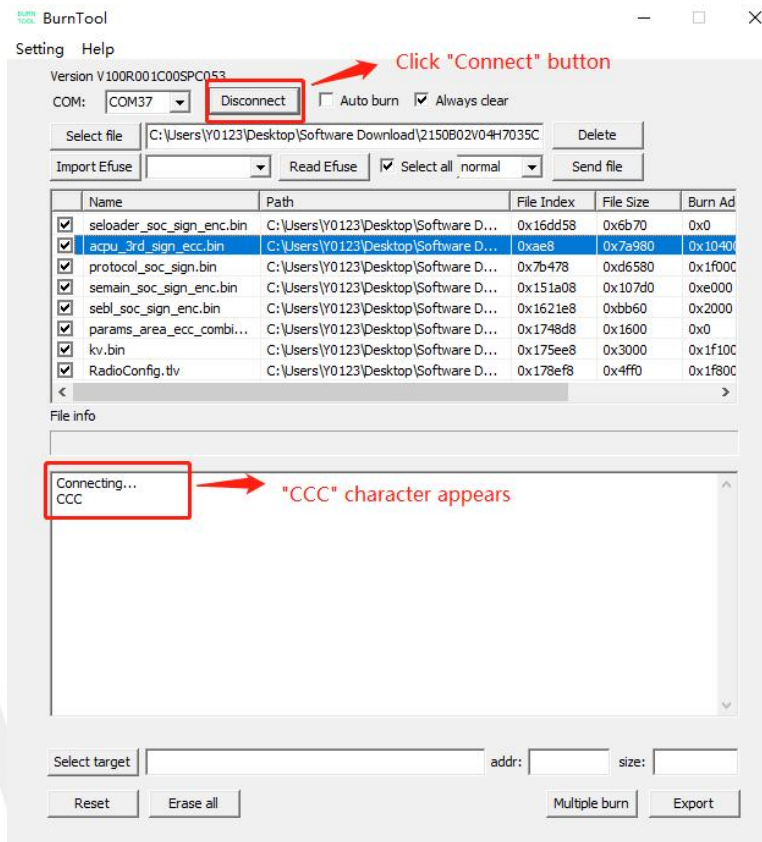

Figure 43: 'CCC' character appears

(5) Click 'Send file' button, download tool will start to download.



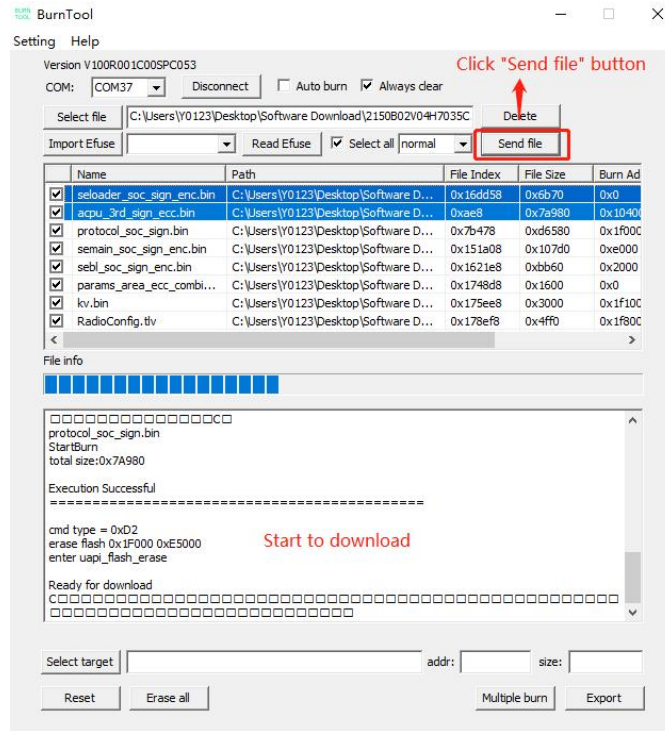

Figure 44: Start to download

(6) Download succeeded.

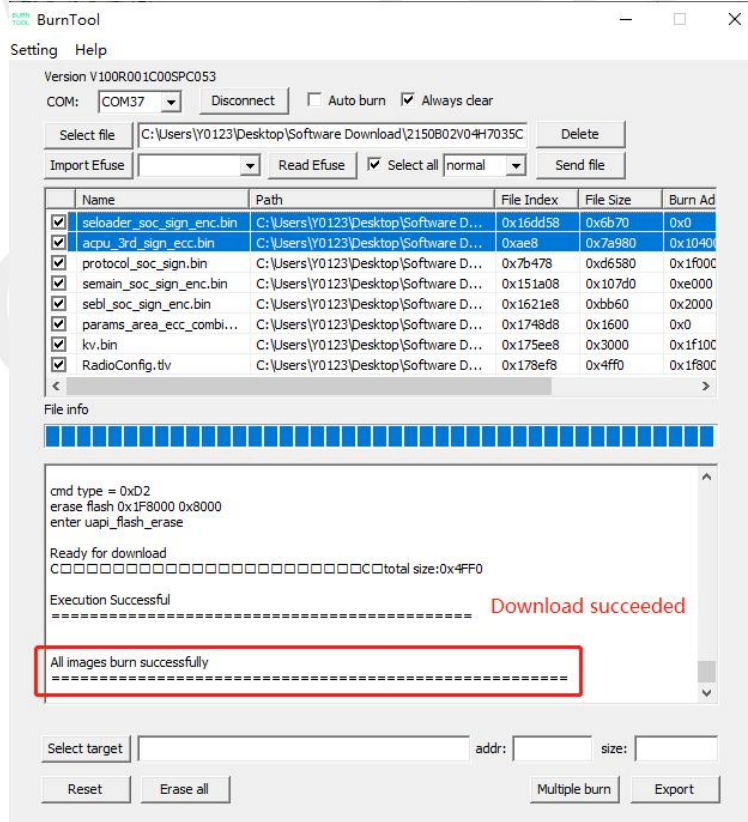

Figure 45: Download succeeded

## 4.4 AT Command Communication

### 4.4.1 UART Serial Port Communication

The data frame format and baud rate of the each module is shown as follows.

#### (1) Serial port data frame format

The default data frame format is 8 data bits, 1 stop bit, and no parity bit.

**Table 22: UART data frame format**

UART data frame format	Support format
Data bit	8bit, 7bit
Stop bit	1bit
Check Digit	None, Even, None

#### (2) Set the serial port baud rate

Each module supports a variety of common baud rates. For modification of baud rate, please refer to the command "AT+IPR".

**Table 23: The default baud rate of each module**

Module model	Default baud rate
SIM7022	115200bps
Y7025	9600bps
Y7025H	9600bps
Y7026	9600bps
Y7012	9600bps
E7025	9600bps
H7035C	115200bps

**Table 24: UART baud rate support**

UART baud rate support	Support rate
Serial communication fix baud rate	4800, 9600, 19200, 38400, 57600, 115200, 230400, 460800, 921600
Serial communication auto baud rate	2400, 4800, 9600, 19200, 38400, 57600, 115200

Common methods of using serial port baud rate commands:

**Table 25: UART baud rate operation**

UART baud rate operation	Related command
Query the current baud rate	AT+IPR?
Query module supports baud rate	AT+IPR=?
Set auto baud rate	AT+IPR=0

SIMCom  
Confidential

## 5. Current Consumption Test

### 5.1 Preparation for Test

Insert the Type-C USB into the J103, and power on the module. Then please check the valid information of the tested module (software version, hardware version, etc.), ensure that the software version and hardware version to be tested are correct.

### 5.2 Current consumption test

1. Confirm the IMEI number of the network card before inserting the card, and send the corresponding IMEI number through the serial port assistant, otherwise the card will be locked.
2. Then insert the network card, register to the network, and query the network registration status through 'AT+CGREG=1'.
3. After the network is successfully registered, turn off functions (such as indicator lights, log, etc.) related to the leakage current through AT commands.
4. Remove all jumpers and pull the J205 to OFF, and then the external power supply should be applied from the test points J507 (VBAT and GND), customer can connect dupont line from here to test current consumption.

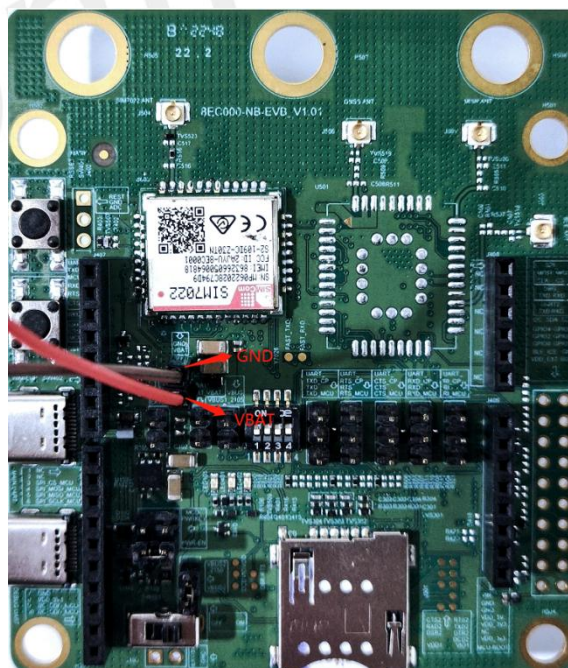

Figure 46: The method of test current consumption

**NOTE**

1. If the current waveform is abnormal, start again from Step 2.

SIMCom  
Confidential

## 6. Appendix

### 6.1 Related Documents

Table 26: Related Documents

No.	Title	Description
[1]	Y7025 Hardware Design	Y7025 Hardware Design document
[2]	Y7026 Hardware Design	Y7026 Hardware Design document
[3]	Y7012 Hardware Design	Y7012 Hardware Design document
[4]	Y7025H Hardware Design	Y7025H Hardware Design document
[5]	SIM7022 Hardware Design	SIM7022 Hardware Design document
[6]	H7035C Hardware Design	H7035C Hardware Design document
[7]	E7025 Hardware Design	E7025 Hardware Design document
[8]	Y70XX Series_AT Command Manual	Y70XX Series AT Command Manual document
[9]	SIM7022 Series_AT Command Manual	SIM7022 Series AT Command Manual document
[10]	H7035C Series_AT Command Manual	H7035C Series AT Command Manual document
[11]	E7025 Series_AT Command Manual	E7025 Series AT Command Manual document







## 6.2 Terms and Abbreviations

Table 27: Terms and abbreviations

Abbreviation	Description
EMC	Electromagnetic Compatibility
ESD	Electrostatic Discharge
GNSS	Global Navigation Satellite System
GPS	Global Positioning System
I2C	Inter-Integrated Circuit
IMEI	International Mobile Equipment Identity
LTE	Long Term Evolution
MSB	Most Significant Bit
PCB	Printed Circuit Board
RF	Radio Frequency
SIM	Subscriber Identification Module
SMPS	Switched-Mode Power Supply
NC	Not connect
ZIF	Zero Intermediate Frequency
(U)SIM	Universal Subscriber Identity Module
UART	Universal Asynchronous Receiver Transmitter

## 6.3 Safety Caution

Table 28: Safety Caution

Marks	Requirements
	<p>When in a hospital or other health care facility, observe the restrictions about the use of mobiles. Switch the cellular terminal or mobile off, medical equipment may be sensitive and not operate normally due to RF energy interference.</p>
	<p>Switch off the cellular terminal or mobile before boarding an aircraft. Make sure it is switched off. The operation of wireless appliances in an aircraft is forbidden to prevent interference with communication systems. Forgetting to think much of these instructions may impact the flight safety, or offend local legal action, or both.</p>
	<p>Do not operate the cellular terminal or mobile in the presence of flammable gases or fumes. Switch off the cellular terminal when you are near petrol stations, fuel depots, chemical plants or where blasting operations are in progress. Operation of any electrical equipment in potentially explosive atmospheres can constitute a safety hazard.</p>
	<p>Your cellular terminal or mobile receives and transmits radio frequency energy while switched on. RF interference can occur if it is used close to TV sets, radios, computers or other electric equipment.</p>
	<p>Road safety comes first! Do not use a hand-held cellular terminal or mobile when driving a vehicle, unless it is securely mounted in a holder for hands free operation. Before making a call with a hand-held terminal or mobile, park the vehicle.</p>
	<p>GSM cellular terminals or mobiles operate over radio frequency signals and cellular networks and cannot be guaranteed to connect in all conditions, especially with a mobile fee or an invalid SIM card. While you are in this condition and need emergent help, please remember to use emergency calls. In order to make or receive calls, the cellular terminal or mobile must be switched on and in a service area with adequate cellular signal strength.</p> <p>Some networks do not allow for emergency call if certain network services or phone features are in use (e.g. lock functions, fixed dialing etc.). You may have to deactivate those features before you can make an emergency call.</p> <p>Also, some networks require that a valid SIM card be properly inserted in the cellular terminal or mobile.</p>