

Datasheet

APM32F103xB

Arm® Cortex®-M3 based 32-bit MCU

Version: V 1.5

1. Features

- System Architecture
 - 32-bit Arm® Cortex®-M3 core
 - Up to 96MHz working frequency
- Clock and Memories
 - HSECLK: 4MHz~16MHz external crystal oscillator supported
 - LSECLK: 32.768KHz RTC oscillator supported
 - HSICLK: 8 MHz RC oscillator with calibration
 - LSICLK: 40 KHz RC oscillator
 - Flash : maximum 128 Kbytes
 - SRAM : maximum 20 Kbytes
- Power supply and low-power mode
 - 2.0 ~ 3.6 V reset supply voltage
 - Support programmable voltage Detector(PVD)
 - Sleep, Stop and Standby modes
 - V_{Bat} power supply can support RTC and backup registers
- FPU
 - Independent FPU module supports floating point operations
- ADCs and Temperature Sensor
 - 2 12-bit ADCs, 16 input channels are supported
 - ADC voltage conversion range: 0~V_{DDA}
 - Double-sample and hold capability supported
 - 1 on-chip temperature sensor
- I/O
 - 80/51/37/26 I/Os selectable, depending on models and packages
 - All I/O pins are mappable to 16 external interrupt
- DMA
 - 1 DMA, 7 separate configurable channels are supported
- Timers
 - 1 16-bit advanced control timer TMR1, support dead zone control and emergency braking functions
 - 3 16-bit general-purpose timers TMR2/3/4, each with up to 4 independent channels to support input capture, output comparison, PWM, pulse count and other functions
 - 2 watchdog timers(Independent IWDT and Window WWDT)
 - 1 24-bit autodecrement SysTick Timer
- Communication Interfaces
 - 3 USART, support ISO7816, LIN and IrDA
 - 2 I2C, support SMBus/PMBus
 - 2 SPI with a maximum transfer speed of 18Mbps
 - 1 QSPI, support single - and four-wire access to Flash
 - 1 USB 2.0 FS Device
 - 1 CAN 2.0B, USB and CAN can work independently at the same time)
- 1 CRC Unit
- 96-bit UID
- Serial wire debug SWD and JTAG interfaces
- Chip Packaging
 - LQFP100/LQFP64/LQFP48/QFN36
- Applications
 - Medical devices, PC peripherals, industrial control, smart meters, household appliances

CONTENTS

1.	Features.....	2
2.	Overview.....	10
3.	Features Description.....	11
3.1.	Arm® Cortex®-M3 Core.....	11
3.2.	Memory.....	12
3.3.	Power Management.....	12
3.3.1.	Power Supply Schemes.....	12
3.3.2.	Voltage Regulator.....	12
3.3.3.	Power Supply Monitor.....	13
3.3.4.	Low Power Mode.....	13
3.4.	Clocks and Startup.....	14
3.5.	RTC and Backup Registers.....	14
3.6.	Boot Modes.....	14
3.7.	CRC (Cyclic Redundancy Check) Calculation Unit.....	14
3.8.	General Purpose IO Port.....	15
3.8.1.	General-purpose Input/Output Interface.....	15
3.9.	Interrupt Controller.....	15
3.9.1.	Nested Vectored Interrupt Controller (NVIC).....	15
3.9.2.	External Interrupt/Event Controller (EINT).....	15
3.10.	Floating Point Unit (FPU).....	15
3.11.	DMA.....	16
3.12.	Timer.....	16
3.13.	Watchdog (WDT).....	17
3.14.	Peripheral Interface.....	17
3.14.1.	I ² C Bus.....	17
3.14.2.	Universal Synchronous/Asynchronous Receiver Transmitter (USART).....	18
3.14.3.	Serial Peripheral Interface (SPI).....	18
3.14.4.	Quad SPI Controller (QSPI).....	18
3.14.5.	Controller Area Network (CAN).....	18
3.14.6.	Universal Serial Bus (USB).....	18
3.14.7.	Simultaneous Use of USB Interface and CAN Interface:.....	18
3.14.8.	ADC (Analog/Digital Converter).....	19
3.14.9.	Temperature Sensor.....	19

3.14.10. Debug Interface (SWJ-DP).....	19
4. Pin Features	20
4.1. Pinouts and Pin Description	20
4.1.1. APM32F103xB Series LQFP100.....	20
4.1.2. APM32F103xB Series LQFP64.....	21
4.1.3. APM32F103xB Series LQFP48.....	22
4.1.4. APM32F103xB Series QFN36.....	23
4.2. Pin Description.....	24
4.3. System Diagram	31
4.4. Clock Tree.....	32
4.5. Address Mapping.....	33
4.6. Power Supply Scheme	34
5. Electrical Features	35
5.1. Parameter Conditions	35
5.1.1. Maximum and Minimum Values.....	35
5.1.2. Typical Value.....	35
5.1.3. Typical Curve	35
5.1.4. Load Capacitance.....	35
5.2. Absolute Maximum Ratings.....	36
5.2.1. Maximum Rated Voltage Features	36
5.2.2. Maximum Rated Current Features	37
5.2.3. Maximum Temperature Features.....	38
5.2.4. Maximum Ratings Electrical Sensitivity.....	38
5.3. Test Under the General Working Conditions	38
5.3.1. Embedded Reset and Power Control Block Features.....	40
5.3.2. Built-in Reference Voltage Features Test	40
5.3.3. Supply Current Features	41
5.3.4. External Clock Source Features.....	49
5.3.5. Internal Clock Source Features	52
5.3.6. PLL Features	54
5.3.7. Memory Features.....	54
5.3.8. I/O Ports Features	55
5.3.9. NRST Pins Features.....	58
5.3.10. Communication Interface.....	58

5.3.11. 12-bit ADC Features	63
5.3.12. Temperature Sensor Features	66
5.3.13. EMC Features	66
6. Packaging Information	68
6.1. LQFP100 Package Diagram	68
6.2. LQFP64 Package Diagram	71
6.3. LQFP48 Package Diagram	74
6.4. QFN36 Package Diagram	77
7. Ordering Information	80
8. Package Information	82
9. Commonly Used Function Module Denomination	86
10. Version History	87

TABLE CONTENTS

Table 1.	APM32F103xB Product Features and Peripheral Configurations	11
Table 2.	Description of Memory	12
Table 3.	Power Supply Schemes.....	12
Table 4.	Operation Modes of Voltage Regulator.....	12
Table 5.	Low Power Mode	13
Table 6.	Timer Feature Comparison	16
Table 7.	Watchdog	17
Table 8.	APM32F103xB Pin Definitions.....	24
Table 9.	Maximum Rated Voltage Features	36
Table 10.	Maximum Rated Current Features	37
Table 11.	Temperature Features.....	38
Table 12.	ESD Absolute Maximum Ratings.....	38
Table 13.	Static Latch	38
Table 14.	General Working Conditions	38
Table 15.	Embedded Reset and Power Control Block Features ($T_A=25^{\circ}\text{C}$) ($-40^{\circ}\text{C}-105^{\circ}\text{C}$)	40
Table 16.	Built-in Reference Voltage	40
Table 17.	Run-mode Current Consumption, Code with Data Processing Running From Internal Flash ..	42
Table 18.	Run-mode Current Consumption, Code with Data processing Running From Internal RAM ...	43
Table 19.	Maximum Current Consumption in Sleep Mode, Code Runs from Flash or RAM	44
Table 20.	Maximum Current Consumption in Stop Mode and Standby Mode	45
Table 21.	Run-mode current consumption, code with data processing running from internal Flash	46
Table 22.	Run-mode current consumption, code with data processing running from internal RAM	47
Table 23.	Typical current consumption in sleep mode, code running from Flash or RAM	48
Table 24.	Typical current Consumption in Stop Mode and Standby Mode	49
Table 25.	HSECLK 4~16MHz Oscillator Features	49
Table 26.	LSECLK Oscillator Features ($f_{LSECLK}=32.768\text{KHz}$)	51
Table 27.	HSICLK Oscillator Features.....	52
Table 28.	LSICLK Oscillator Features	53
Table 29.	Wake Up Time in Low Power Mode.....	53
Table 30.	PLL Features	54
Table 31.	FLASH Memory Features (1).....	54
Table 32.	FLASH Memory Life and Data Retention Period.....	54
Table 33.	I/O Static Features (Test conditions $V_{CC}=2.7-3.6\text{V}$, $T_A = -40\sim 105^{\circ}\text{C}$).....	55

Table 34.	Voltage Features (test conditions $V_{CC}=2.7-3.6V, T_A = -40\sim 105^{\circ}C$).....	56
Table 35.	Input and Output AC Features	56
Table 36.	NRST NRST Pin Features (Test condition $V_{CC}=3.3V, T_A = -40\sim 105^{\circ}C$)	58
Table 37.	I2C Interface Features (Test conditions $V_{DD} = 3.3V, T_A = 25^{\circ}C$)	58
Table 38.	SPI Features ($V_{DD}= 3.3V, T_A =25^{\circ}C$)	60
Table 39.	USBD DC Characteristics.....	62
Table 40.	ADC Features ($V_{DD}= 2.4-3.6V, T_A =-40\sim 105^{\circ}C$).....	63
Table 41.	Maximum RAIN at $f_{ADC}=14MHz$ (1)	64
Table 42.	ADC Accuracy.....	65
Table 43.	Temperature Sensor Features.....	66
Table 44.	EMS Features	67
Table 45.	EMI Features	67
Table 46.	LQFP100 Package Data.....	69
Table 47.	LQFP64 Package Data.....	72
Table 48.	LQFP Package Data.....	75
Table 49.	QFN36 Package Data.....	78
Table 50.	Ordering Information Table	81
Table 51.	Strip Package Parameters Specification	83
Table 52.	Tray Package Diagram	84
Table 53.	Tray Package Parameters Specification.....	84
Table 54.	Commonly Used Function Module Denomination	86
Table 55.	Document Reversion History	87

FIGURE CONTENTS

Figure 1. LQFP100 Pinout	20
Figure 2. LQFP64 Pinout	21
Figure 3. LQFP48 Pinout	22
Figure 4. QFN36 Pinout	23
Figure 5. APM32F103xB Series System Diagram.....	31
Figure 6. APM32F103xB Series Clock Tree	32
Figure 7. APM32F103xB Series Address Mapping Diagram.....	33
Figure 8. Power Supply Scheme	34
Figure 9. Load Conditions When Measuring Pin Parameters	35
Figure 10.Pin Input Voltage Measurement Scheme	36
Figure 11.Current Consumption Measurement Scheme	36
Figure 12.Typical application of 8MHz crystal oscillator.....	51
Figure 13.Typical application of 32.768MHz crystal oscillator.....	52
Figure 14.Input and Output AC Features Definition	57
Figure 15.Bus AC Waveform and Measurement Circuit ⁽¹⁾	59
Figure 16.Timing Diagram - Slave Mode and CPHA=0.....	61
Figure 17.SPI Timing Diagram - Slave Mode and CPHA=0	61
Figure 18.SPI Timing Diagram - Master Mode ⁽³⁾	62
Figure 19.USBTD Timing: Definition of Data Signal Rise and Fall Times	63
Figure 20.Typical application of ADC.....	64
Figure 21.ADC Accuracy Characteristics	66
Figure 22.LQFP100 Package Diagram	68
Figure 23.LQFP100-100 pins,14x14mm welding Layout proposal	70
Figure 24.LQFP100-100 pin,14x14mm package identification diagram	70
Figure 25.LQFP64 Package Diagram	71
Figure 26.LQFP64-64 pin,10x10mm welding Layout proposal	73
Figure 27.LQFP64-64 pin,10x10mm package identification diagram	73
Figure 28.LQFP48 Package Diagram	74
Figure 29.LQFP48-48 pin,7x7mm welding Layout proposal	76
Figure 30.LQFP48-48 pin,7x7mm identification diagram	76
Figure 31.QFN36 Package Diagram	77
Figure 32.QFN36 pin, 6 x 6mm Welding Layout Proposal	79
Figure 33.QFN36 pin, 6x6mm identification diagram	79

Figure 34.Strip Package Specification Diagram 82

Figure 35.Tray Package Diagram 84

2. Overview

The APM32F103xB series chips are Arm® Cortex®-M3 core based 32-bit microcontrollers with a maximum operating frequency of 96MHz. Built-in AHB high-performance bus, combined with high-speed memory and DMA for fast data processing and storage. The built-in APB advanced peripheral bus expands the rich peripherals and enhanced I/O, ensuring fast connection and control flexibility. The chips are equipped with a powerful FPU floating-point arithmetic processing unit that supports single-precision data processing instructions and data types.

Built-in up to 128K bytes of flash memory and 20K bytes of SRAM memory, and all models include 2 12-bit ADCs, 3 general-purpose 16-bit timers, 1 advanced control timer and 1 temperature sensor, as well as standard communication interfaces: 2 I2C interfaces, 2 SPI interfaces, 1 QSPI interface, 3 USART interfaces, 1 USB 2.0 FS interface and 1 CAN 2.0B interface(USBD and CAN can work independently at the same time).

Operating voltage is 2.0V ~ 3.6V, there are two types of operating temperature range selectable: -40°C~+85°C and -40°C~+105°C. Available for four different package forms of LQFP100/LQFP64/LQFP48/QFN36, with different peripherals and I/O configurations.

For information about the Arm® Cortex®-M3 core, please refer to the Arm® Cortex®-M3 technical reference manual, which can be downloaded from Arm's website.

3. Features Description

See the following table for specific APM32F103xB product functions and peripheral configuration.

Table 1. Functions and peripherals of APM32F103xB

Product		APM32F103xB			
		TB	CB	RB	VB
Packaging		QFN36	LQFP48	LQFP 64	LQFP 100
Flash(Kbytes)		128			
SRAM(Kbytes)		20			
Timers	General-purpose(16-bit)	3			
	Advanced(16-bit)	1			
	SysTick	1			
	Watchdog	2			
	RTC	1			
Communication Interfaces	SPI	1	2		
	QSPI	0			1
	I2C	1	2		
	USART	2	3		
	CAN2.0B	1			
	USB2.0 FS	1			
12 bit ADC	Unit	2			
	Channel	10		16	
GPIOs		26	37	51	80
CPU@Max. frequency		M3@96MHz			
FPU		1			
Operating voltage		2.0 V~ 3.6 V			

3.1. Arm® Cortex®-M3 Core

APM32F103xB series with built-in Arm® Cortex®-M3 core, 96MHz working frequency, and are compatible with Arm's tools and softwares.

System diagram of APM32F103xB series products is shown in Figure 5.

3.2. Memory

Table 2. Memory Description

Memory	The biggest byte	Function
Embedded High-speed Flash	128 Kbytes	For storing programs and data
Embedded Static Memory	20 Kbytes	Can be accessed in bytes, halfwords(16 bits) or full words(32 bits)

3.3. Power Management

3.3.1. Power Supply Schemes

Table 3. Power Supply Schemes

Name	Voltage Range	Description
V_{DD}	2.0~3.6V	V_{DD} directly supplies power to IO port, and V_{DD} supplies power to core circuit through voltage regulator.
V_{DDA}	2.4~3.6V	Connected to V_{DD} , it supplies power to the analog parts of ADC, reset module, RC oscillator and PLL. When ADC is being used, V_{DDA} is greater than or equal to 2.4V. V_{DDA} and V_{SSA} must be connected to V_{DD} and V_{SS} respectively.
V_{BAT}	1.8V~3.6V	Automatically supply power to RTC, external 32KHz oscillator and backup registers when V_{DD} is off.

Note: See Figure 8 for more details on how to connect power supply pins.

3.3.2. Voltage Regulator

There are three main modes of voltage regulator. The working mode of MCU can be adjusted by voltage regulator to reduce power consumption.

Table 4. Operation Modes of Voltage Regulator

Name	Description
Main Mode(MR)	1.6V power supply(core, memory, peripherals) in normal regulation mode
Low Power Mode(LPR)	1.6V power supply in low power mode to preserve the contents of register and SRAM
Power Down Mode	Used in Standby mode: the regulator output is in high

Name	Description
	impedance: the kernel circuitry is powered down, inducing zero consumption (but the contents of the registers and SRAM are lost)

This regulator is always enabled after reset, and outputs with high impedance in power-down mode.

3.3.3. Power Supply Monitor

Two circuits of power-on reset (POR) and power-down reset (PDR), are integrated inside the product. When V_{DD} reaches the set threshold $V_{POR/PDR}$, the system works normally. When V_{DD} is below the specified threshold $V_{POR/PDR}$, the system remains in a reset state without the need for an external reset circuit.

For details of $V_{POR/PDR}$, please refer to the electrical feature in chapter 5.

3.3.4. Low Power Mode

The product supports the following three low power consumption modes, which can be configured by users to meet the best application requirements.

Table 5. Low Power Consumption Mode

Mode Types	Description
Sleep Mode	In Sleep mode, only the CPU is stopped. All peripherals continue to operate and can wake up the CPU when an interrupt/event occurs.
Stop Mode	The Stop mode achieves the lowest power consumption while retaining the content of SRAM and registers. At this point, part of the 1.6V power supply are stopped, resulting in the HSECLK, HSICLK, and PLL clocks are disabled. The voltage regulator is either in normal or in low-power mode. Interrupt, event wakeup configured as EINT can wake up the CPU from stop mode.
Standby Mode	The Standby mode is used to achieve the lowest power consumption. The internal voltage regulator is switched off so that part of 1.6 V domain is powered off. The HSECLK, HSICLK, and PLL clocks are also switched off. The contents of SRAM and registers are lost, but contents of the backup registers will still remain, and the standby circuit will still work. The external reset signal on NRST, IWDT, will reset an ascending edge on the WKUP pin or the RTC clock will then terminate the chip standby mode.

Note: The RTC, the IWDT, and the corresponding clock sources are not stopped by

entering stop or standby mode. QSPI interrupts cannot wake up low power mode.

3.4. Clocks and Startup

The internal 8MHz RC oscillator serves as the default clock for system startup, and can be switched to the external 4-16mhz clock with failure monitoring through configuration.

When an external clock failure is detected, the system will automatically switch to an internal RC oscillator, and if an interrupt is set, the software can receive the related interrupt.

The frequencies of AHB high-speed APB(APB2) and low-speed APB(APB1) can be configured through the predivider. The maximum frequency of AHB and high-speed APB is 96MHz and that of low speed APB is 48MHz.

See Figure 6 for details on the clock tree.

3.5. RTC and Backup Registers

The RTC has a set of continuously running counters, which can provide calendar alarm interruption and stage interruption functions with softwares. Its clock source can choose external 32.768khz crystal oscillator, internal 40KHz low-speed RC oscillator or external high-speed clock with 128 frequency division. Moreover, the RTC clock can be calibrated for errors through a 512Hz signal.

A backup register for 10 16-bit registers to hold 20 bytes of user data when VDD is off.

RTC and backup registers are powered by V_{DD} when V_{DD} is in effect; otherwise, it will be powered by V_{BAT} pins. System or power reset source reset, waking up from standby mode, does not cause the reset of RTC and backup register.

3.6. Boot Modes

At startup, you can choose one of three bootstrap modes through the bootstrap pin:

- Boot from User Flash
- Boot from System Memory
- Boot from embedded SRAM

The boot loader is located in System Memory. It is used to reprogram the Flash memory by using USART1.

3.7. CRC (Cyclic Redundancy Check) Calculation Unit

The CRC (Cyclic Redundancy Check) calculation unit is used to get a CRC code from a 32-bit data word and a fixed generator polynomial.

The CRC calculation unit helps compute a signature of the software during runTime, to be compared with a reference signature generated at link-Time and stored at a given memory location.

3.8. General Purpose IO Port

80/51/37/26 I/O is available for the product, and the specific selection can refer to the model and package. All I/O can be mapped to 16 external interrupt controllers, and most of I/O support 5V logic level input.

3.8.1. General-purpose Input\Output Interface

The product can be up to 80 GPIO pins, each of the GPIOs can be configured by software as output (push-pull or open-drain), as input (with or without pull-up or pull-down) or as peripheral alternate function. Most of the GPIO pins are shared with digital or analog alternate functions. All GPIOs are high current-capable.

The I/Os alternate function configuration can be locked if needed following a specific sequence in order to avoid spurious writing to the I/Os registers. I/Os on APB2 with up to 18 MHz toggling speed.

3.9. Interrupt Controller

3.9.1. Nested Vectored Interrupt Controller (NVIC)

- It can handle 16 priority levels and maskable interrupt channels simultaneously. The closely coupled NVIC gives low-latency interrupt processing.
- Interrupt entry vector table address passed directly to the core
- Allow early processing of interrupts.
- Processing of late arriving higher priority interrupts
- Support for tail-chaining
- Processor state is automatically saved.
- Interrupt entry restored on interrupt exit with no instruction overhead
- This hardware block provides flexible interrupt management features with minimal interrupt latency.

3.9.2. External Interrupt/Event Controller (EINT)

The external interrupt/event controller consists of 19 edge detector lines used to generate interrupt/event requests. Each line can be independently configured to select the trigger event (rising edge, falling edge, both) and can be masked independently. A pending register maintains the status of the interrupt requests. Up to 80 GPIOs can be connected to the 16 external interrupt lines. The EINT can detect an external line with a pulse width shorter than the Internal APB2 clock period.

3.10. Floating Point Unit (FPU)

The product has a embedded independent FPU floating-point arithmetic processing unit that

supports the IEEE754 standard and supports single-precision floating-point operations.

3.11. DMA

The flexible 7-channel general-purpose DMA is able to manage memory-to-memory, peripheral-to-memory and memory-to-peripheral transfers.

Each channel is connected to dedicated hardware DMA requests, with support for software trigger on each channel. Configuration is made by software and transfer sizes between source and destination are independent.

The DMA can be used with the main peripherals: SPI, I2C, USART, general-purpose and advanced-control Timers TMRx and ADC.

3.12. Timer

The product includes an advanced-control Timer (TMR1), three general-purpose Timers (TMR2/3/4), an independent watchdog Timer, a window watchdog Timer, and a SysTickTimer.

The following table compares the features of the advanced-control and general-purpose Timers:

Table 6. Timer Feature Comparison

Type of Timer	SysTick Timer	General-purpose Timer			Advanced -control Timer
Timer	Sys Tick Timer	TMR2	TMR3	TRM4	TMR1
Counter Resolution	24-bit	16-bit			16-bit
Counter Type	Down	Up, down, up/down			Up, down, up/down
Prescaler Factor	-	Any integer between 1 and 65536			Any integer between 1 and 65536
DMA Request generation	-	Yes			Yes
Capture/Compare Channels	-	4			4
Complementary Outputs	-	No			Yes
Function Specification	Dedicated for OS Automatic reload function Maskable system interrupt generation when the counter reaches 0 Programmable clock	Synchronization or event chaining function provided. Counters can be frozen in debug mode Can be used to generate PWM outputs			Complementary PWM outputs with programmable inserted dead-Times If configured as a general-purpose 16-bit Timer, it has the same features as the TMRx Timer.

	source	Each Timer has independent DMA request generation. It can handle quadrature (incremental) encoder signals and the digital outputs from 1 to 3 hall-effect sensors	If configured as the 16-bit PWM generator, it has full modulation capability (0-100%). In debug mode, the advanced-control Timer counter can be frozen and the PWM outputs disabled. Synchronization or event chaining provided
--	--------	--	---

3.13. Watchdog (WDT)

The product includes two watchdogs, providing greater security, Time accuracy and flexibility. The two watchdogs(independent and window watchdog)can be used for detecting and resolving failures caused by software errors. When the counter reaches a given Timeout value, an interrupt is triggered (for window watchdogs only) or a system reset is generated.

Table 7. Watchdog

Watchdog	Counter Resolution	Counter Type	Prescale Factor	functional
Independent Watchdog	12-bit	down	Any integer between 1 and 256	It is clocked from an independent 40 kHz internal RC oscillator and as it operates independently from the main clock, it can operate in stop and standby modes. Reset the device when a problem occurs. As a free-running Timer for application Timeout management. It is hardware- or software-configurable through the option bytes. The counter can be frozen in debug mode.
Window Watchdog	7-bit	down	-	It can be set as free-running. Reset the device when a problem occurs. It is clocked from the main clock. It has an early warning interrupt capability. The counter can be frozen in debug mode.

3.14. Peripheral Interface

3.14.1. I²C Bus

Two embedded I²C (I²C1, I²C2) bus interfaces can operate in multimaster or slave mode. They can support standard and fast modes. They support dual slave addressing (7-bit only) and both

7/10-bit addressing in master mode. A hardware CRC generation/verification is embedded. They can be served by DMA and they support SM Bus 2.0/PM Bus.

I²C3/4 bus extended the function of I²C 1/2. They can operate in standard, fast and high speed mode. The fast mode and high speed mode devices are backwards compatible.

3.14.2. Universal Synchronous/Asynchronous Receiver Transmitter (USART)

Three USART communication interfaces are embedded, providing hardware management of the CTS and RTS signals, and IrDA SIR ENDEC supported. They are ISO 7816 compliant and have LIN Master/Slave capability. One of the USART interfaces is able to communicate at speeds of up to 4.5 Mbit/s. The other available interfaces communicate at up to 2.25 Mbit/s. All USART interfaces can be served by the DMA controller.

3.14.3. Serial Peripheral Interface (SPI)

Two SPIs are able to communicate up to 18 Mbits/s in slave and master modes in full-duplex and simplex communication modes while the frame is configurable to 8 bits or 16 bits. Both SPIs can be served by the DMA controller.

3.14.4. Quad SPI Controller (QSPI)

The product has an embedded QSPI dedicated communication interface that can be connected to external flash via single, dual or quad SPI mode, supporting 8-bit, 16-bit and 32-bit access. There are 8 bytes of transmit FIFO and 8 bytes of receive FIFO.

3.14.5. Controller Area Network (CAN)

The CAN is compliant with specifications 2.0A and B (active) with a bit rate up to 1 Mbit/s. It can receive and transmit standard frames with 11-bit identifiers as well as extended frames with 29-bit identifiers. It has three transmit mailboxes, two receive FIFOs with 3 stages and 14 scalable filter banks.

3.14.6. Universe Serial Bus (USB D)

The product embeds a USB D device peripheral compatible with the USB2.0 full-speed 12 Mbs. The USB D interface implements a full-speed (12 Mbit/s) function interface. It has software-configurable endpoint setting and suspend/resume support. The dedicated 48 MHz clock is generated from the internal main PLL (the clock source must use a HSECLK crystal oscillator).

3.14.7. Simultaneous Use of USB D Interface and CAN Interface:

When USB D and CAN are used together, you need to:

- Write 0x00000001 at the base address offset 0x100 of the USB D.

- The PA11 and PA12 pins are for USB and CAN is used to multiplex other pins.

3.14.8. ADC (Analog/Digital Converter)

Two 12-bit analog-to-digital converters are embedded into APM32F103x8xb performance line devices and each ADC shares up to 16 external channels, performing conversions in single-shot or scan modes. In scan mode, automatic conversion is performed on a selected group of analog inputs.

Additional logic functions embedded in the ADC interface allow:

- Simultaneous sample and hold
- Interleaved sample and hold
- Single shunt

The ADC can be served by the DMA controller.

An analog watchdog feature allows very precise monitoring of the converted voltage of one, some or all selected channels. An interrupt is generated when the converted voltage is outside the programmed thresholds.

The events generated by the general-purpose Timers (TMRx) and the advanced-control Timer (TMR1) can be internally connected to the ADC start trigger, injection trigger, and DMA trigger respectively, to allow the application to synchronize A/D conversion and Timers.

3.14.9. Temperature Sensor

The temperature sensor has to generate a voltage that varies linearly with temperature. The conversion range is between $2\text{ V} < V_{DDA} < 3.6\text{ V}$. The temperature sensor is internally connected to the ADC12_IN16 input channel which is used to convert the sensor output voltage into a digital value.

3.14.10. Debug Interface (SWJ-DP)

The product supports serial debug interface (SW-DP) and JTAG (JTAG-DP) debug interface.

The JTAG interface provides a 5-pin standard JTAG interface for the AHB access port. The SW-DP interface provides a 2-pin (data + clock) interface to the AHB module.

The two pins of the SW-DP interface and the five pins of the JTAG interface are multiplexed.

4. Pin Features

4.1. Pinouts and Pin Description

4.1.1. APM32F103xB Series LQFP100

Figure 1. LQFP100 Pinout

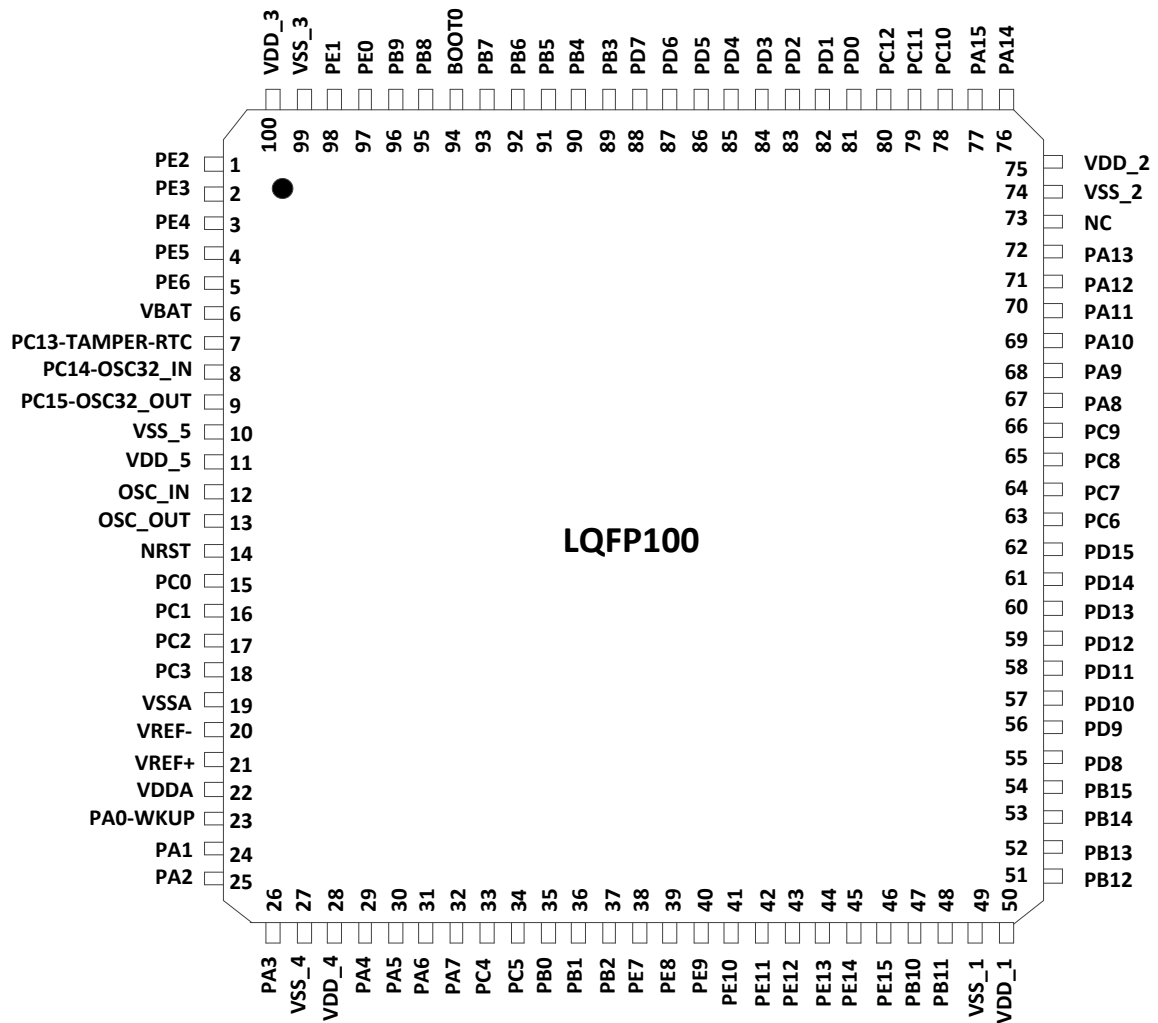

4.1.2. APM32F103xB Series LQFP64

Figure 2. LQFP64 Pinout

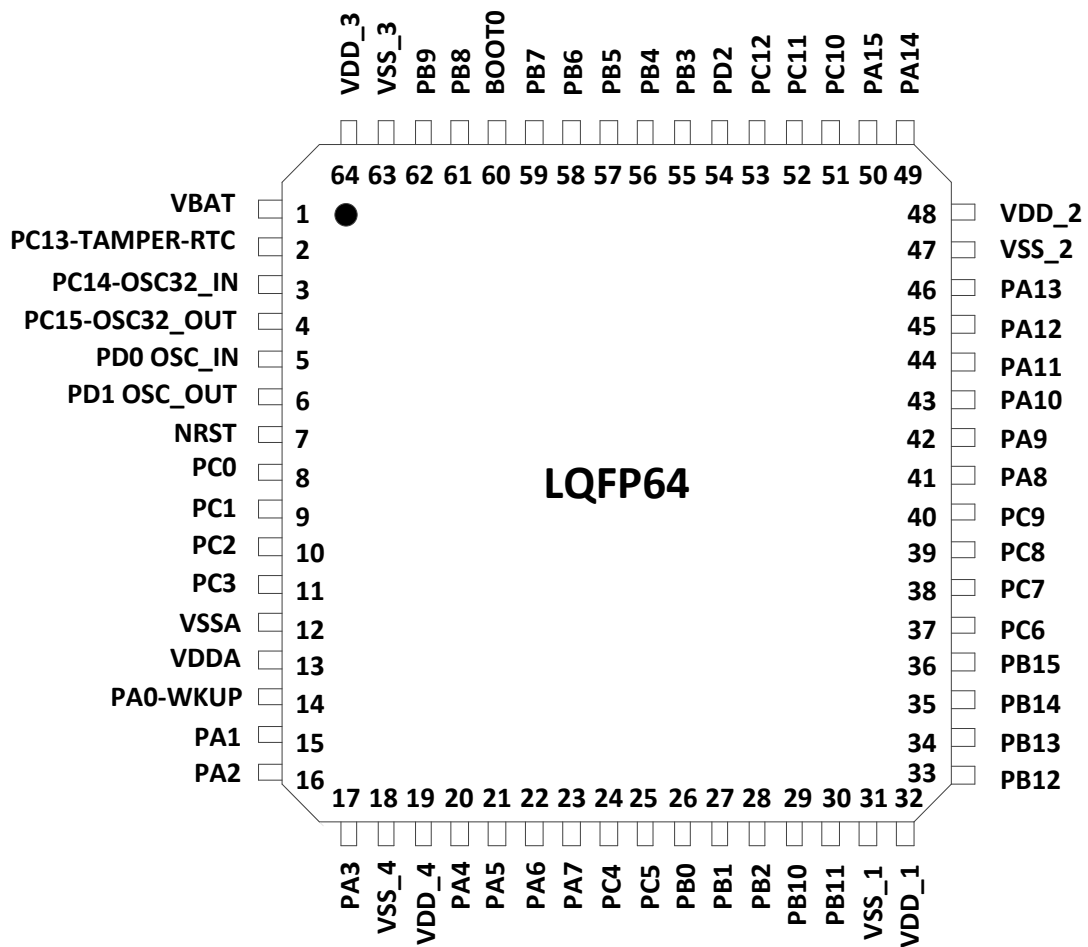

4.1.3. APM32F103xB Series LQFP48

Figure 3. LQFP48 Pinout

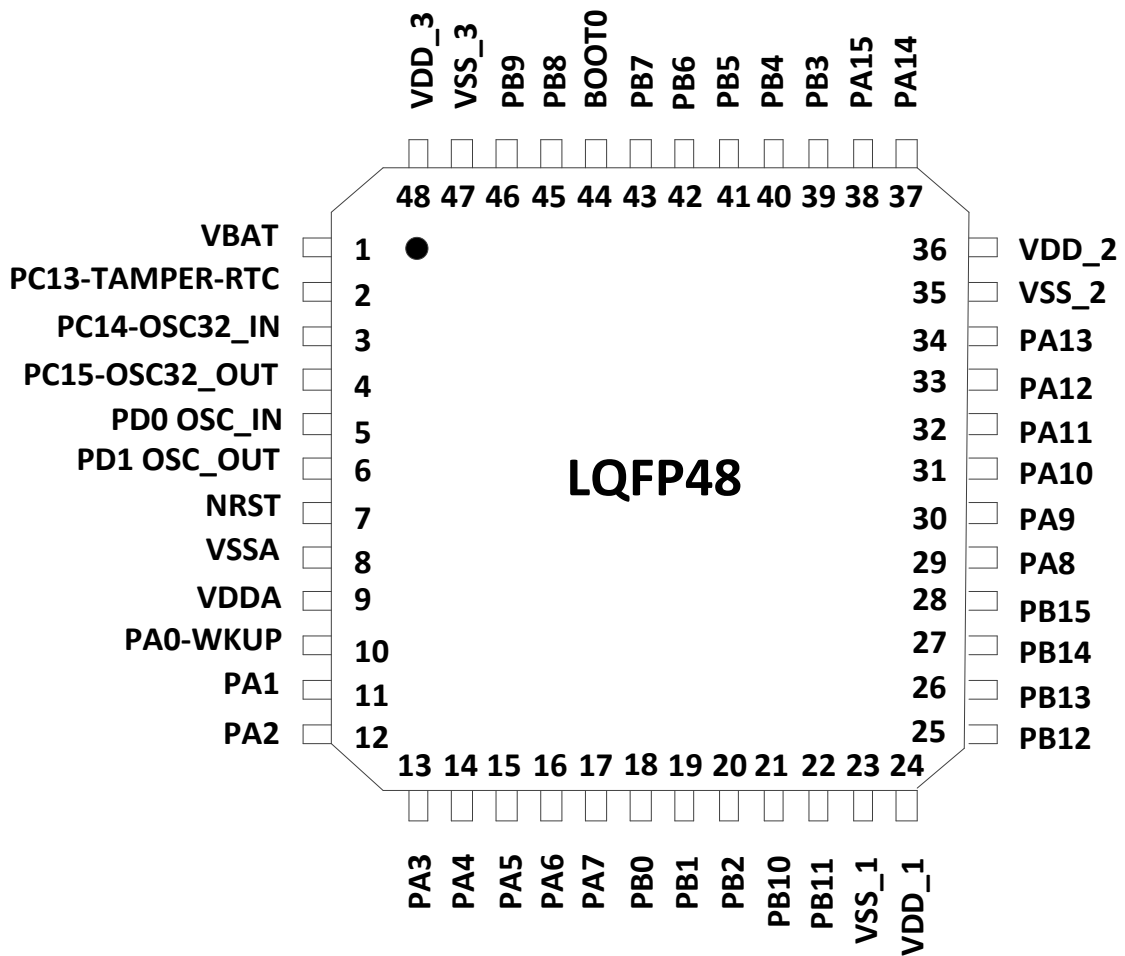

4.1.4. APM32F103xB Series QFN36

Figure 4. QFN36 Pinout

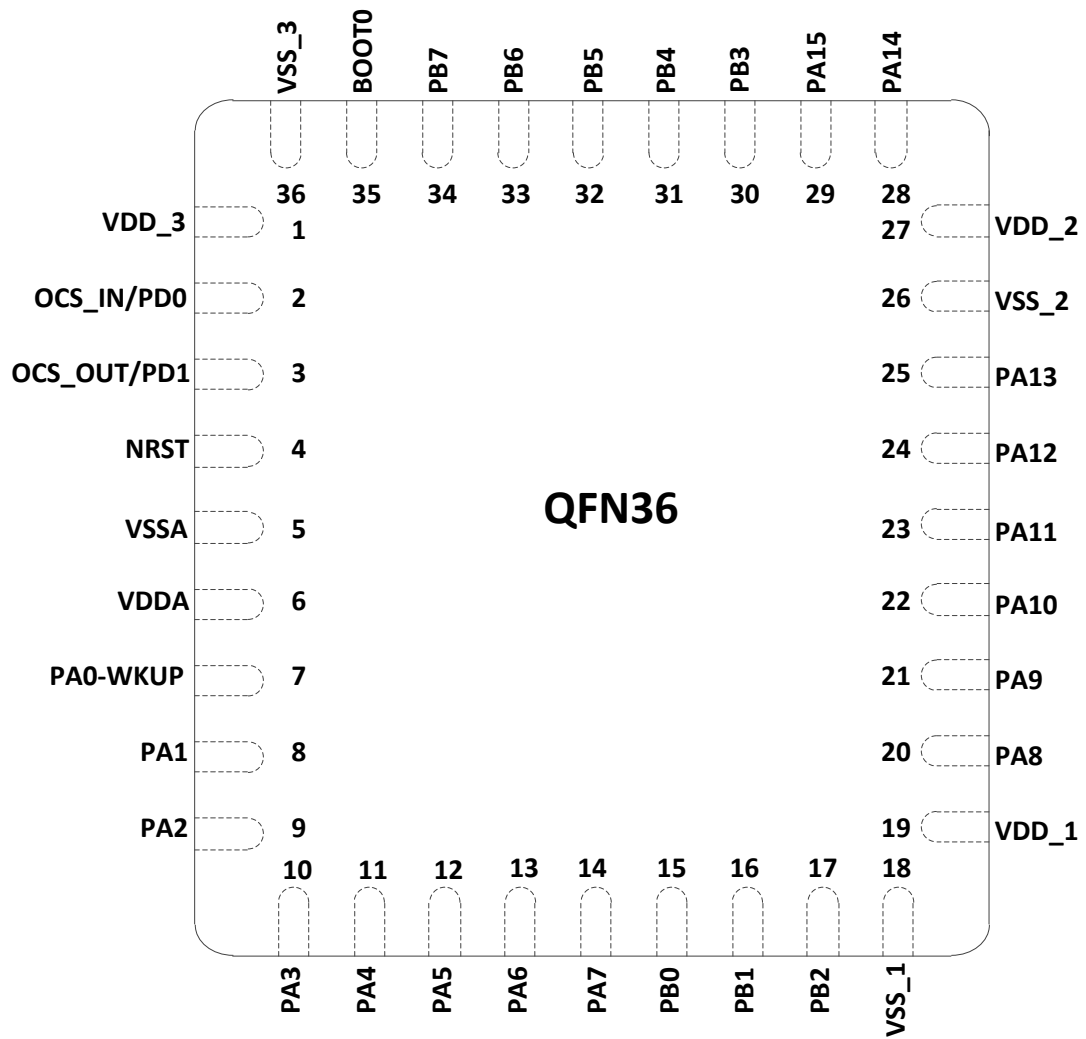

4.2. Pin Description

Table 8. APM32F103xB Pin Definitions

Pin Name	Pins				Type (1)	I/O level (2)	Main Function (3)	Alternate functions	
	LQFP48	LQFP64	LQFP100	QFN36			(after reset)	Default	Remap
PE2	-	-	1	-	I/O	FT	PE2	TRACECK	-
PE3	-	-	2	-	I/O	FT	PE3	TRACED0	-
PE4	-	-	3	-	I/O	FT	PE4	TRACED1	-
PE5	-	-	4	-	I/O	FT	PE5	TRACED2	-
PE6	-	-	5	-	I/O	FT	PE6	TRACED3	-
V _{BAT}	1	1	6	-	S	-	V _{BAT}	-	-
PC13- TAMPER-RTC ⁽⁴⁾	2	2	7	-	I/O	-	PC13 ⁽³⁾	TAMPER-RTC	-
PC14- OSC32_IN ⁽⁴⁾	3	3	8	-	I/O	-	PC14 ⁽³⁾	OSC32_IN	-
PC15- OSC32_OUT ⁽⁴⁾	4	4	9	-	I/O	-	PC15 ⁽³⁾	OSC32_OUT	-
V _{SS_5}	-	-	10	-	S	-	V _{SS_5}	-	-
V _{DD_5}	-	-	11	-	S	-	V _{DD_5}	-	-
OSC_IN	5	5	12	2	I	-	OSC_IN	-	PD0 ⁽⁵⁾
OSC_OUT	6	6	13	3	O	-	OSC_OUT	-	PD1 ⁽⁵⁾
NRST	7	7	14	4	I/O	-	NRST	-	-
PC0	-	8	15	-	I/O	-	PC0	ADC12_IN10	-
PC1	-	9	16	-	I/O	-	PC1	ADC12_IN11	-
PC2	-	10	17	-	I/O	-	PC2	ADC12_IN12	-
PC3	-	11	18	-	I/O	-	PC3	ADC12_IN13	-
V _{SSA}	8	12	19	5	S	-	V _{SSA}	-	-
V _{REF-}	-	-	20	-	S	-	V _{REF-}	-	-
V _{REF+}	-	-	21	-	S	-	V _{REF+}	-	-
V _{DDA}	9	13	22	6	S	-	V _{DDA}	-	-

Pin Name	Pins				Type (1)	I/O level (2)	Main Function (3)	Alternate functions	
	LQFP48	LQFP64	LQFP100	QFN36			(after reset)	Default	Remap
PA0-WKUP	10	14	23	7	I/O	-	PA0	WKUP/ USART2_CTS ⁽⁶⁾ / ADC12_IN0/ TMR2_CH1_ETR ⁽⁶⁾	-
PA1	11	15	24	8	I/O	-	PA1	USART2_RTS ⁽⁶⁾ / ADC12_IN1/ TMR2_CH2 ⁽⁶⁾	-
PA2	12	16	25	9	I/O	-	PA2	USART2_TX ⁽⁶⁾ / ADC12_IN2/ TMR2_CH3 ⁽⁶⁾	-
PA3	13	17	26	10	I/O	-	PA3	USART2_RX ⁽⁶⁾ / ADC12_IN3/ TMR2_CH4 ⁽⁶⁾	-
V _{SS_4}	-	18	27	-	S	-	V _{SS_4}	-	-
V _{DD_4}	-	19	28	-	S	-	V _{DD_4}	-	-
PA4	14	20	29	11	I/O	-	PA4	SPI1_NSS ⁽⁶⁾ / USART2_CK ⁽⁶⁾ / ADC12_IN4	-
PA5	15	21	30	12	I/O	-	PA5	SPI1_SCK ⁽⁶⁾ / ADC12_IN5	-
PA6	16	22	31	13	I/O	-	PA6	SPI1_MISO ⁽⁶⁾ / ADC12_IN6/ TMR3_CH1 ⁽⁶⁾	TMR1_BKIN
PA7	17	23	32	14	I/O	-	PA7	SPI1_MOSI ⁽⁶⁾ / ADC12_IN7/ TMR3_CH2 ⁽⁶⁾	TMR1_CH1N
PC4	-	24	33	-	I/O	-	PC4	ADC12_IN14	-
PC5	-	25	34	-	I/O	-	PC5	ADC12_IN15	-
PB0	18	26	35	15	I/O	-	PB0	ADC12_IN8/ TMR3_CH3 ⁽⁶⁾	TMR1_CH2N
PB1	19	27	36	16	I/O	-	PB1	ADC12_IN9/ TMR3_CH4 ⁽⁶⁾	TMR1_CH3N

Pin Name	Pins				Type (1)	I/O level (2)	Main Function (3)	Alternate functions	
	LQFP48	LQFP64	LQFP100	QFN36			(after reset)	Default	Remap
PB2	20	28	37	17	I/O	FT	PB2/BOOT 1	-	-
PE7	-	-	38	-	I/O	FT	PE7	-	TMR1_ETR
PE8	-	-	39	-	I/O	FT	PE8	-	TMR1_CH1N
PE9	-	-	40	-	I/O	FT	PE9	-	TMR1_CH1
PE10	-	-	41	-	I/O	FT	PE10	-	TMR1_CH2N
PE11	-	-	42	-	I/O	FT	PE11	-	TMR1_CH2
PE12	-	-	43	-	I/O	FT	PE12	-	TMR1_CH3N
PE13	-	-	44	-	I/O	FT	PE13	-	TMR1_CH3
PE14	-	-	45	-	I/O	FT	PE14	-	TMR1_CH4
PE15	-	-	46	-	I/O	FT	PE15	-	TMR1_BKIN
PB10	21	29	47	-	I/O	FT	PB10	I ² C2_SCL/ I ² C4_SCL/ USART3_TX ⁽⁶⁾	TMR2_CH3
PB11	22	30	48	-	I/O	FT	PB11	I ² C2_SDA/ I ² C4_SDA/ USART3_RX ⁽⁶⁾	TMR2_CH4
V _{SS_1}	23	31	49	18	S	-	V _{SS_1}	-	-
V _{DD_1}	24	32	50	19	S	-	V _{DD_1}	-	-
PB12	25	33	51	-	I/O	FT	PB12	SPI2_NSS/ I ² C2_SMBAL/ USART3_CK ⁽⁶⁾ / TMR1_BKIN ⁽⁶⁾	
PB13	26	34	52	-	I/O	FT	PB13	SPI2_SCK/ USART3_CTS ⁽⁶⁾ / TMR1_CH1N ⁽⁶⁾ / QSPI_IO0	
PB14	27	35	53	-	I/O	FT	PB14	SPI2_MISO/ USART3_RTS ⁽⁶⁾ / TMR1_CH2N ⁽⁶⁾	

Pin Name	Pins				Type (1)	I/O level (2)	Main Function (3)	Alternate functions	
	LQFP48	LQFP64	LQFP100	QFN36				(after reset)	Default
								QSPI_IO1	
PB15	28	36	54	-	I/O	FT	PB15	SPI2_MOSI/ TMR1_CH3N ⁽⁶⁾ / QSPI_IO2	-
PD8	-	-	55	-	I/O	FT	PD8	QSPI_IO3	USART3_TX
PD9	-	-	56	-	I/O	FT	PD9	-	USART3_RX
PD10	-	-	57	-	I/O	FT	PD10	QSPI_CLK	USART3_CK
PD11	-	-	58	-	I/O	FT	PD11	-	USART3_CTS
PD12	-	-	59	-	I/O	FT	PD12	QSPI_SS_N	TMR4_CH1/ USART3_RTS
PD13	-	-	60	-	I/O	FT	PD13	-	TMR4_CH2
PD14	-	-	61	-	I/O	FT	PD14	-	TMR4_CH3
PD15	-	-	62	-	I/O	FT	PD15	-	TMR4_CH4
PC6	-	37	63	-	I/O	FT	PC6	-	TMR3_CH1
PC7	-	38	64	-	I/O	FT	PC7	-	TMR3_CH2
PC8	-	39	65	-	I/O	FT	PC8	-	TMR3_CH3
PC9	-	40	66	-	I/O	FT	PC9	-	TMR3_CH4
PA8	29	41	67	20	I/O	FT	PA8	USART1_CK/ TMR1_CH1 ⁽⁶⁾ / MCO	-
PA9	30	42	68	21	I/O	FT	PA9	USART1_TX ⁽⁶⁾ / TMR1_CH2 ⁽⁶⁾	-
PA10	31	43	69	22	I/O	FT	PA10	USART1_RX ⁽⁶⁾ / TMR1_CH3 ⁽⁶⁾	-
PA11	32	44	70	23	I/O	FT	PA11	USART1_CTS/USBDM/ USB2DM/ CAN_RX ⁽⁶⁾ / TMR1_CH4 ⁽⁶⁾	-
PA12	33	45	71	24	I/O	FT	PA12	USART1_RTS/ USBDP/USB2DP/	-

Pin Name	Pins				Type (1)	I/O level (2)	Main Function (3) (after reset)	Alternate functions	
	LQFP48	LQFP64	LQFP100	QFN36				Default	Remap
								CAN_TX ⁽⁶⁾ / TMR1_ETR ⁽⁶⁾	
PA13	34	46	72	25	I/O	FT	JTMS/ SWDIO	-	PA13
Disconnected	-	-	73	-	-	-	-	Disconnected	-
V _{SS_2}	35	47	74	26	S		V _{SS_2}	-	-
V _{DD_2}	36	48	75	27	S		V _{DD_2}	-	-
PA14	37	49	76	28	I/O	FT	JTCK/ SWCLK	-	PA14
PA15	38	50	77	29	I/O	FT	JTDI	-	TMR2_CH1_E TR/PA15/ SPI1_NSS
PC10	-	51	78	-	I/O	FT	PC10	-	USART3_TX
PC11	-	52	79	-	I/O	FT	PC11	-	USART3_RX
PC12	-	53	80	-	I/O	FT	PC12	-	USART3_CK
PD0	-	-	81	2	I/O	FT	PD0	-	CAN_RX
PD1	-	-	82	3	I/O	FT	PD1	-	CAN_TX
PD2	-	54	83	-	I/O	FT	PD2	TMR3_ETR	-
PD3	-	-	84	-	I/O	FT	PD3	-	USART2_CTS
PD4	-	-	85	-	I/O	FT	PD4	-	USART2_RTS
PD5	-	-	86	-	I/O	FT	PD5	-	USART2_TX
PD6	-	-	87	-	I/O	FT	PD6	-	USART2_RX
PD7	-	-	88	-	I/O	FT	PD7	-	USART2_CK
PB3	39	55	89	30	I/O	FT	JTDO	-	PB3/ TRACESWO TMR2_CH2/ SPI1_SCK

Pin Name	Pins				Type (1)	I/O level (2)	Main Function (3)	Alternate functions	
	LQFP48	LQFP64	LQFP100	QFN36				(after reset)	Default
PB4	40	56	90	31	I/O	FT	NJTRST	-	PB4/ TMR3_CH1/ SPI1_MISO
PB5	41	57	91	32	I/O	-	PB5	I ² C1_SMBAI	TMR3_CH2/ SPI1_MOSI
PB6	42	58	92	33	I/O	FT	PB6	I ² C1_SCL ⁽⁶⁾ / I ² C3_SCL/ TMR4_CH1 ⁽⁶⁾	USART1_TX
PB7	43	59	93	34	I/O	FT	PB7	I ² C1_SDA ⁽⁶⁾ / I ² C3_SDA/ TMR4_CH2 ⁽⁶⁾	USART1_RX
BOOT0	44	60	94	35	I	-	BOOT0	-	-
PB8	45	61	95	-	I/O	FT	PB8	TMR4_CH3 ⁽⁶⁾	I ² C1_SCL/ (I ² C3_SCL/ CAN_RX
PB9	46	62	96	-	I/O	FT	PB9	TMR4_CH4 ⁽⁶⁾	I ² C1_SDA (I ² C3_SDA) / CAN_TX
PE0	-	-	97	-	I/O	FT	PE0	TMR4_ETR	-
PE1	-	-	98	-	I/O	FT	PE1	-	-
V _{SS_3}	47	63	99	36	S	-	V _{SS_3}	-	-
V _{DD_3}	48	64	100	1	S	-	V _{DD_3}	-	-

- (1) I = input, O = output, S = supply, HiZ = high resistance
- (2) FT = 5V tolerant.
- (3) Function availability depends on the chosen device. For devices having reduced peripheral counts, it is always the lower number of peripheral that is included. For example, if a device has only one SPI and two USARTs, they will be called SPI1 and USART1 & USART2, respectively.
- (4) PC13, PC14 and PC15 are supplied through the power switch since the switch only sinks a limited amount of current (3mA). The use of GPIOs from PC13 to PC15 in output mode is limited: only one GPIO can be used at a Time, the speed should not exceed 2 MHz with a maximum load of 30pF and these IOs must not be used as a current source (e.g. to drive an

- LED).
- (5) Main function after the first backup domain power-up. Later on, it depends on the contents of the Backup registers even after reset (because these registers are not reset by the main reset). For details on how to manage these IOs, refer to the Battery backup domain and BAKR register description sections in the reference manual.
 - (6) This alternate function can be remapped by software to some other port pins (if available on the used package). For more details, refer to the alternate function I/O and debug configuration section in the reference manual.

4.3. System Diagram

Figure 5. APM32F103xB Series System Diagram

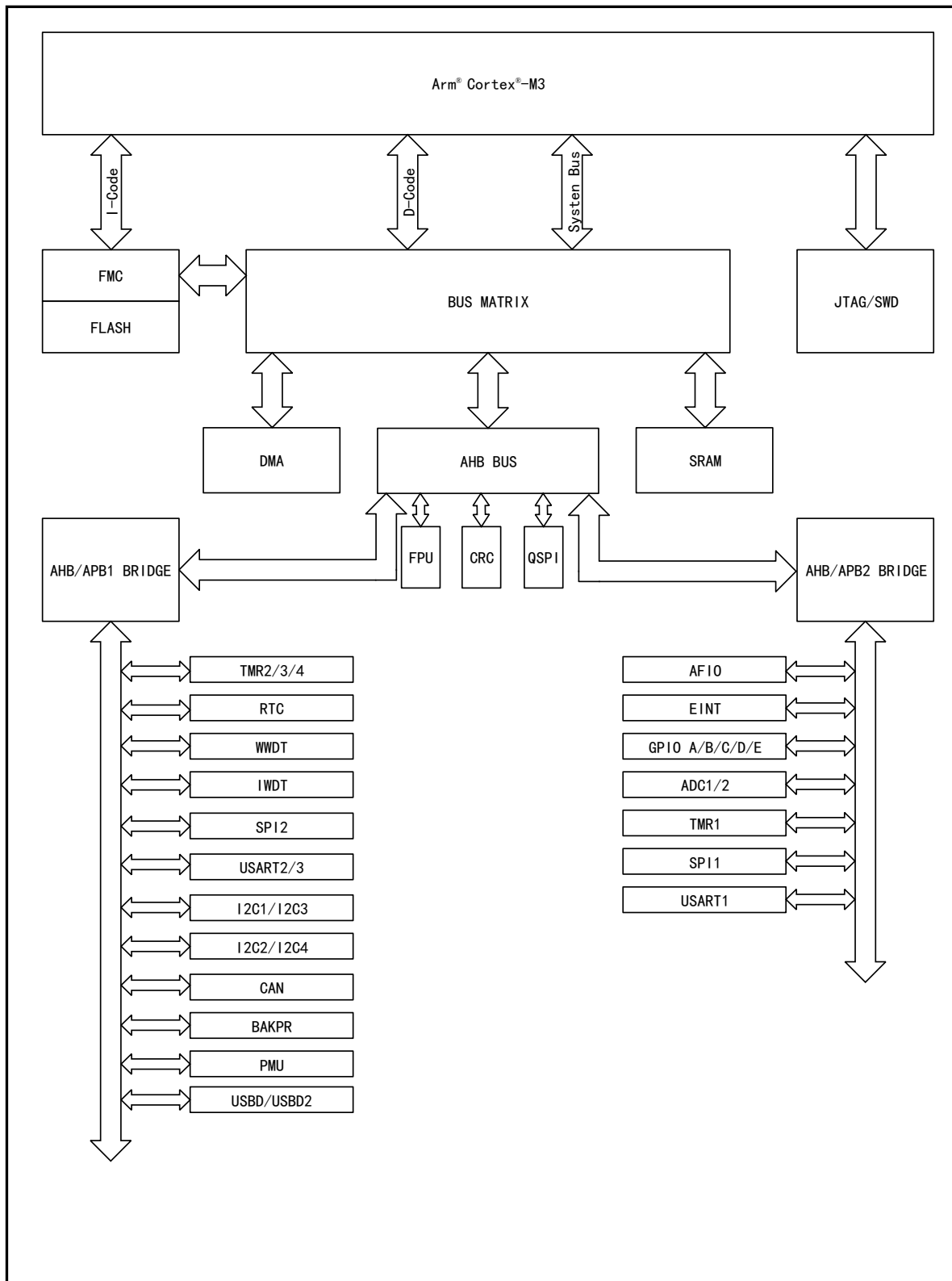

- (1) The max frequency for APM32F103xB series AHB and high-speed APB is 96MHz;
- (2) The max frequency for APM32F103xB series low-speed APB clock is 48MHz.

4.4. Clock Tree

Figure 6. APM32F103xB Series Clock Tree

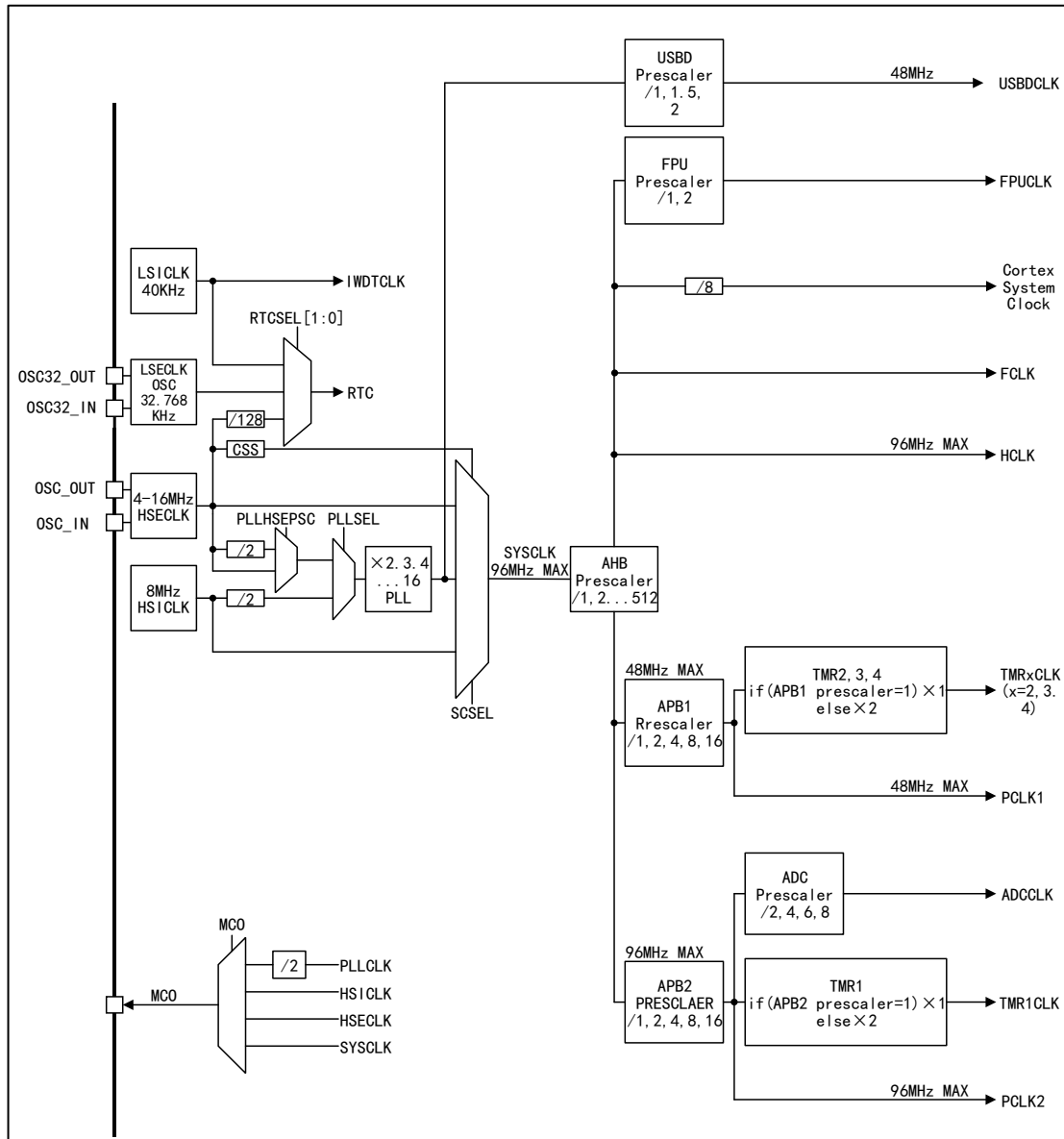

- (1) The max frequency for APM32F103xB series AHB and high-speed APB is 96MHz;
- (2) The max frequency for APM32F103xB series low-speed APB clock is 48MHz.

4.5. Address Mapping

Figure 7. APM32F103xB Series Address Mapping Diagram

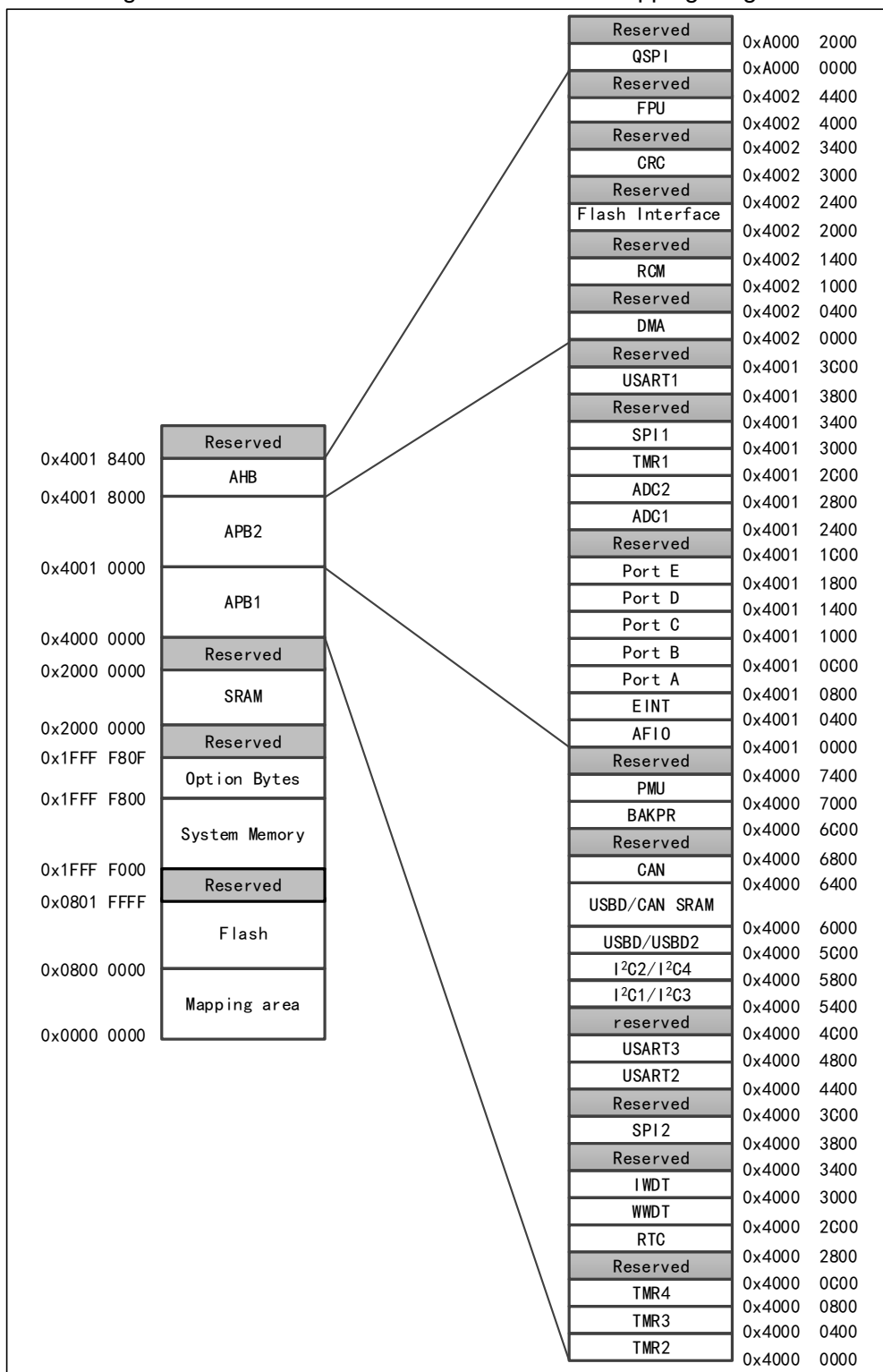

4.6. Power Supply Scheme

Figure 8. Power Supply Scheme

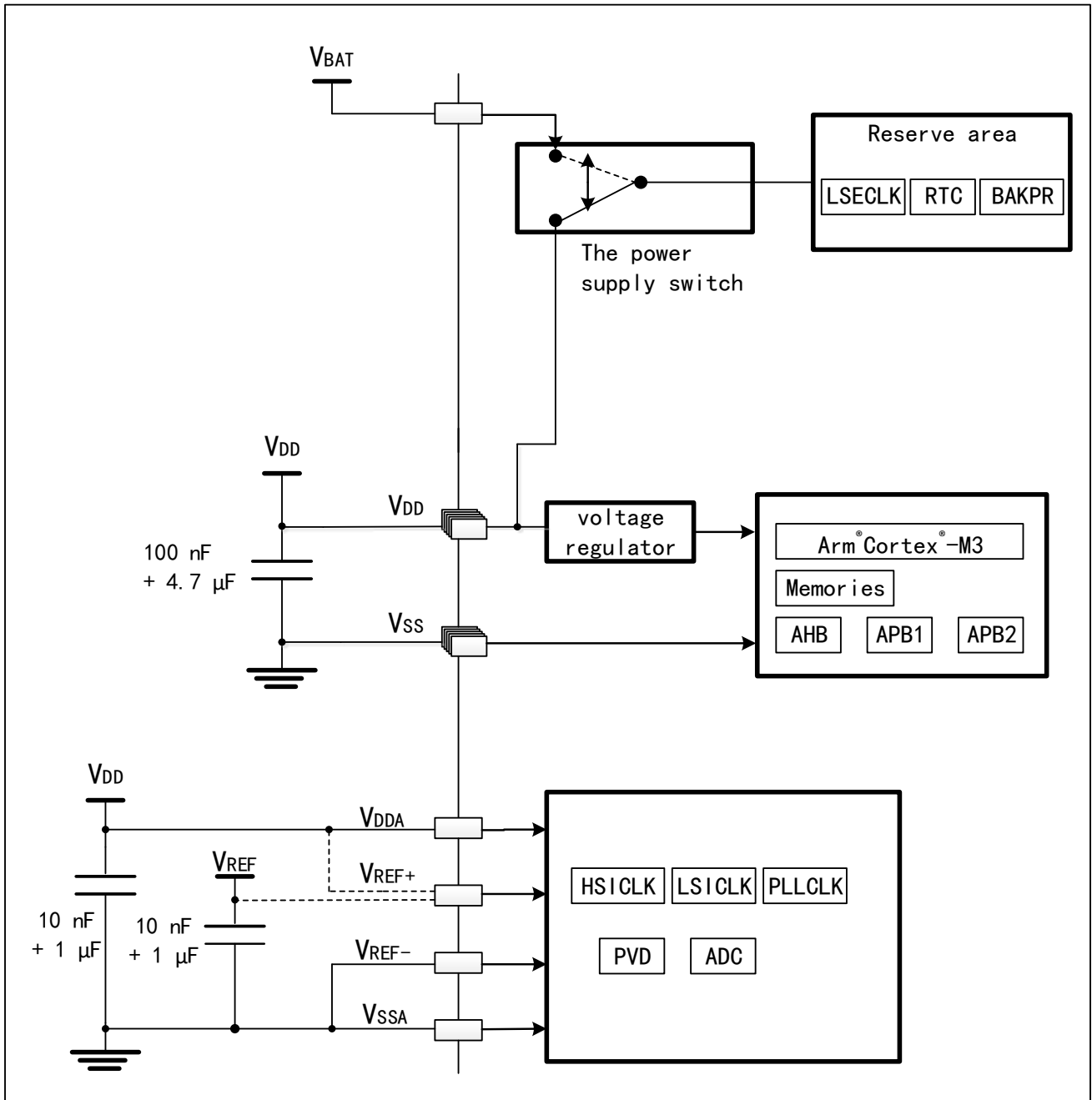

5. Electrical Features

5.1. Parameter Conditions

All voltage parameters are referenced to VSS unless otherwise specified

5.1.1. Maximum and Minimum Values

Unless otherwise stated, all minimum and maximum values are guaranteed on the production line by testing 100% of the product at ambient temperature $T_A=25^{\circ}\text{C}$ under worst ambient temperature, supply voltage and clock frequency conditions.

Take notes in every table that the data got for passing the comprehensive evaluation, design simulation or process features will not be tested on production lines. Basing on the comprehensive evaluation and sample tested, the minimum and maximum values come from the average value's plus or subtract its triple value on the standard distribution (average $\pm 3\Sigma$).

5.1.2. Typical Value

Typical data is based on $T_A = 25^{\circ}\text{C}$ and $V_{DD} = 3.3\text{V}$ ($2\text{ V} \leq V_{DD} \leq 3.3\text{ V}$ voltage range) unless otherwise stated. These data are for design guidance only.

5.1.3. Typical Curve

Typical curves are for design guidance only and are not tested unless otherwise stated.

5.1.4. Load Capacitance

Figure 9. Load Conditions When Measuring Pin Parameters

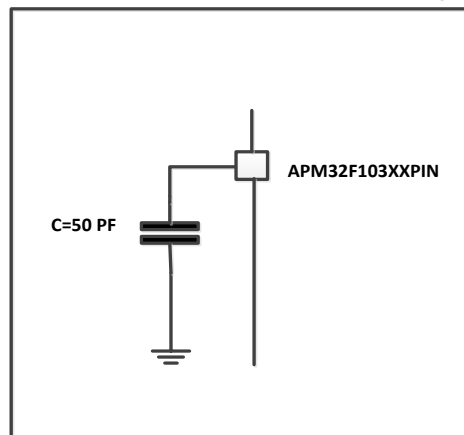

A: load capacitance

Figure 10. Pin Input Voltage Measurement Scheme

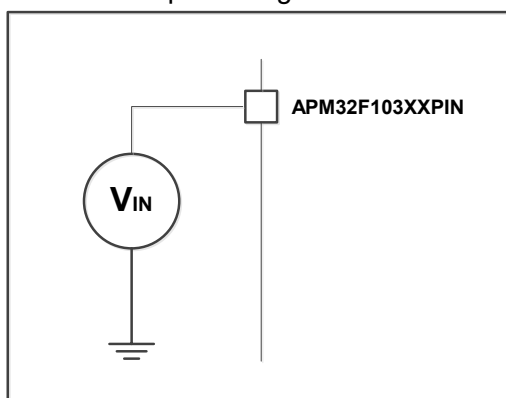

B: Pin Input Voltage

Figure 11. Current Consumption Measurement Scheme

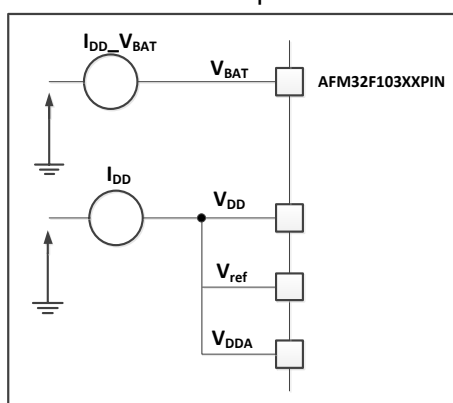

C: Current consumption measurement($I_{DD}+V_{ref}$)

5.2. Absolute Maximum Ratings

Loads applied to the device may cause permanent damage to the device if the absolute maximum ratings are given in the maximum rated voltage Features and maximum rated current Features. This is just to give the maximum load that can be tolerated, and does not mean that the functionality of the device is functioning properly under these conditions. The reliability of device would be affected if it works under the maximum load conditions for a long Time.

5.2.1. Maximum Rated Voltage Features

Table 9. Maximum Rated Voltage Features

Symbol	Description	Minimum	Maximum	Unit
$V_{DD} - V_{SS}$	External main supply voltage (including V_{DDA} and V_{DD}) ⁽¹⁾	-0.3	4.0	V
V_{IN}	Input voltage on 5V tolerant pins ⁽²⁾	$V_{SS}-0.3$	5.5	
	Input voltage on other pins ⁽²⁾	$V_{SS}-0.3$	$V_{DD} + 0.3$	
$ \Delta V_{DDx} $	Voltage difference between different supply pins		50	mV

Symbol	Description	Minimum	Maximum	Unit
$ V_{SSx}-V_{SS} $	Voltage difference between different ground pins		50	

- (1) All power (V_{DD} , V_{DDA}) and ground (V_{SS} , V_{SSA}) pins must always be connected to a power supply within the external allowable range.
- (2) If V_{IN} does not exceed the maximum value, $I_{INJ(PIN)}$ will not exceed its limit. If V_{IN} exceeds the maximum value, $I_{INJ(PIN)}$ must be externally limited to not exceed its maximum value. When $V_{IN} > V_{DD}$, there is a forward injection current; when $V_{IN} < V_{SS}$, there is a reverse injection current.

5.2.2. Maximum Rated Current Features

Table 10. Maximum Rated Current Features

Symbol	Description	Maximum	Unit
I_{VDD}	Total current (supply current) ⁽¹⁾ went through the V_{DD}/V_{DDA} power cord.	150	mA
I_{VSS}	Total current (outflow current) ⁽¹⁾ went through the V_{SS} ground cord.	150	
I_{IO}	Irrigation current on any I/O and control pins	25	
	Source current on any I/O and control pins	-25	
$I_{INJ(PIN)}$ ^{(2) (3)}	Injection current of NRST pin	± 5	
	Injection current of HSECLK's OSC_IN pin and LSECLK's OSC_IN pin	± 5	
	Injection current of other pins	± 5	
$\Sigma I_{INJ(PIN)}$ ⁽²⁾	Total injection current on all I/O and control pins ⁽⁴⁾	± 25	

- (1) All power (V_{DD} , V_{DDA}) and ground (V_{SS} , V_{SSA}) pins must always be connected to a power supply within the external allowable range.
- (2) If V_{IN} does not exceed the maximum value, $I_{INJ(PIN)}$ will not exceed its limit. If V_{IN} exceeds the maximum value, $I_{INJ(PIN)}$ must be externally limited to not exceed its maximum value. When $V_{IN} > V_{DD}$, there is a forward injection current; when $V_{IN} < V_{SS}$, there is a reverse injection current.
- (3) Reverse injection current can interfere with the analog performance of the ADC.
- (4) When several I/O ports have injection current at the same Time, the maximum value of $\Sigma I_{INJ(PIN)}$ is the sum of the instantaneous absolute values of the forward injection current and the reverse injection current. These results are based on the calculation of the maximum value of $\Sigma I_{INJ(PIN)}$ on the four I/O port pins of the device.

5.2.3. Maximum Temperature Features

Table 11. Temperature Features

Symbol	Description	Value	Unit
T _{STG}	Storage temperature range	-55 ~ + 150	°C
T _J	Maximum junction temperature	150	°C

5.2.4. Maximum Ratings Electrical Sensitivity Electrostatic Discharge (ESD)

Electrostatic discharges (a positive then a negative pulse separated by 1 second) are applied to the pins of each sample according to each pin combination. The sample size is 3parts x(n+1) supply pins. The test is compliant with JS-001-2017/JS-002-2018 standard.

Table 12. ESD Absolute Maximum Ratings ⁽¹⁾

Symbol	Ratings	Conditions	Maximum value ⁽¹⁾	Unit
V _{ESD(HBM)}	Electrostatic discharge voltage (human body model)	T _A = +25 °C, compliant with standard JS-001-2017	2000	V
V _{ESD(CDM)}	Electrostatic discharge voltage (charging device model)	T _A = +25 °C, compliant with standard JS-002-2018	1000	

(1) The sample is measured by a third-party testing agency and is not tested in production
Static Latch-up(LU)

When running a simple application (controlling 2 LED flashes through I/O ports), the test sample is subjected to false electromagnetic interference until an error occurs, and the flashing LED indicating the error is for evaluating the latch performance. Two complementary static tests are required on six parts to assess the latch-up performance:

- A supply overvoltage is applied to each power supply pin
- A current injection is applied to each input, output and configurable I/O pin The test is compliant with EIA/JESD78E latch-up standard.

Table 13. Static Latch ⁽¹⁾

Symbol	Parameters	Conditions	Type
LU	Static latch	T _A = +25 °C/105°C, compliant with standard EIA/JESD78E	CLASS II A

(1) The sample is measured by a third-party testing agency and is not tested in production.

5.3. Test Under the General Working Conditions

Table 14. General Working Conditions

Symbol	Parameters	Conditions	Min value	Max value	Unit
f_{HCLK}	Internal AHB clock frequency		0	96	MHz
f_{PCLK1}	Internal APB1 clock frequency		0	48	
f_{PCLK2}	Internal APB2 clock frequency		0	96	
V_{DD}	Standard working voltage		2	3.6	V
$V_{DDA}^{(1)}$	Analog operating voltage (ADC not used)	must be the same with $V_{DD}^{(2)}$	2	3.6	V
	Analog operating voltage (ADC not used)		2.4	3.6	
V_{BAT}	Backup operating voltage		1.6	3.6	V
TA	Ambient temperature range (temperature label 6)	Maximum power consumption	-40	105	°C
	Ambient temperature range (temperature label 7)	Maximum power consumption	-40	105	°C
TJ	Junction temperature range		-40	150	°C

(1) When the ADC is used, refer to Chapter 5.2.16.

(2) It is recommended to power V_{DD} and V_{DDA} from the same source. A maximum difference of 300mV between V_{DD} and V_{DDA} can be tolerated during power-up and operation.

5.3.1. Embedded Reset and Power Control Block Features

Table 15.Embedded Reset and Power Control Block Features ($T_A=25^{\circ}\text{C}$) ($-40^{\circ}\text{C}\sim+105^{\circ}\text{C}$)

Symbol	Parameters	Conditions	Minimum Value	Typical Value	Maximum Value	Unit
$V_{PVD}^{(3)}$	Programmable voltage detector level selection	PLS[2:0]=000 (rising edge)	2.18	2.2	2.22	V
		PLS[2:0]=000 (falling edge)	2.08	2.09	2.11	V
		PLS[2:0]=001 (rising edge)	2.28	2.3	2.32	V
		PLS[2:0]=001 (falling edge)	2.17	2.19	2.21	V
		PLS[2:0]=010 (rising edge)	2.38	2.4	2.42	V
		PLS[2:0]=010 (falling edge)	2.27	2.29	2.31	V
		PLS[2:0]=011 (rising edge)	2.48	2.5	2.52	V
		PLS[2:0]=011 (falling edge)	2.37	2.39	2.41	V
		PLS[2:0]=100 (rising edge)	2.58	2.6	2.62	V
		PLS[2:0]=100 (falling edge)	2.47	2.49	2.51	V
		PLS[2:0]=101 (rising edge)	2.67	2.69	2.72	V
		PLS[2:0]=101 (falling edge)	2.57	2.59	2.61	V
		PLS[2:0]=110 (rising edge)	2.77	2.8	2.82	V
		PLS[2:0]=110 (falling edge)	2.66	2.68	2.71	V
		PLS[2:0]=111 (rising edge)	2.86	2.89	2.91	V
		PLS[2:0]=111 (falling edge)	2.76	2.79	2.81	V
$V_{PVDhyst}^{(2)}$	PVD hysteresis			107		mV
$V_{POR/PDR}$	Power on/power down reset threshold	Falling edge	1.87 ⁽¹⁾	1.89	1.91	V
		Rising edge	1.92	1.94	1.96	V
$V_{PDRhyst}^{(2)}$	PVD hysteresis			50		mV
$T_{RSTTEMPO}$	Reset Duration		0.9		2.4	ms

(1) The product feature is guaranteed from design down to the minimum VPOR/PDR value.

(2) It is guaranteed from design, and is not tested in production.

(3) It is derived from a comprehensive evaluation and is not tested in production.

5.3.2. Built-in Reference Voltage Features Test

Table 16.Built-in Reference Voltage

Symbol	Parameters	Conditions	Minimum Value	Typical Value	Maximum Value	Unit
$V_{REFINT}^{(1)}$	Internal reference voltage	$-40^{\circ}\text{C} < T_A < +105^{\circ}\text{C}$ $V_{DD}= 2-3.6\text{ V}$	1.16	1.21	1.26	V
$T_{S_refint}^{(2)}$	ADC sampling Time			5.1	17.1	μs

Symbol	Parameters	Conditions	Minimum Value	Typical Value	Maximum Value	Unit
	when reading the internal reference voltage					
V _{REFINT}	Variation of the built-in reference voltage in full temperature range	V _{DD} =3V±10mV			20	mV
T _{Coeff}					126	ppm/°C

- (1) Data was derived from a comprehensive evaluation and is not tested in production.
- (2) It is guaranteed from design, and is not tested in production.

5.3.3. Supply Current Features

The current values in the operating modes given in this section are measured by executing Dhrystone 2.1, the compilation environment is Keil V5, and the compilation optimization level is L3.

Max Current Consumption

The microcontroller is under the following conditions:

- All I/O pins are in input mode and are connected to a static level –V_{DD} or V_{SS} (no load).
- All peripherals are turned off unless otherwise stated.
- The access time of the flash memory is adjusted to the frequency f_{HCMU} (0~24MHz - 0 wait cycles, 24~48MHz - 1 wait cycle, 48~72MHz - 2 wait cycles, 72~96MHz - 3 wait cycles).
- The instruction prefetch function is turned on (hint: this setting must be made before the clock setting and bus division).
- When the peripheral is turned on: f_{PCMU1} = f_{HCMU}/2, f_{PCMU2} = f_{HCMU}.

Table 17. Run-mode Current Consumption, Code with Data Processing Running From Internal Flash

Symbol	Parameters	Conditions	f _{HCLK}	Maximum Value ⁽¹⁾	Unit
				T _A =105°C , V _{DD} =3.6 V	
I _{DD}	Supply current in operating mode	External clock ⁽²⁾ , enabling all peripherals	96 MHz	31.05	mA
			72MHz	25.78	
			48MHz	19.82	
			36MHz	15.19	
			24MHz	11.47	
			16MHz	8.01	
			8MHz	4.41	
		External clock ⁽²⁾ , turn off all peripherals	96 MHz	20.03	
			72MHz	17.60	
			48MHz	14.24	
			36MHz	10.89	
			24MHz	8.65	
			16MHz	6.30	
			8MHz	3.54	

(1) Data was derived from a comprehensive evaluation and is not tested in production.

(2) When the external clock is 8MHz and f_{HCMU} >8MHz, it enables PLL.

Table 18. Run-mode Current Consumption, Code with Data processing Running From Internal RAM

Symbol	Parameters	Conditions	f _{HCLK}	Maximum Value ⁽¹⁾	Unit
				T _A =105°C , V _{DD} =3.6 V	
I _{DD}	Supply current in operating mode	External clock ⁽²⁾ , enabling all peripherals	96 MHz	27.82	mA
			72MHz	21.82	
			48MHz	14.39	
			36MHz	11.02	
			24MHz	7.69	
			16MHz	5.45	
			8MHz	3.20	
		External clock ⁽²⁾ , turn off all peripherals	96 MHz	16.85	
			72MHz	12.74	
			48MHz	8.86	
			36MHz	6.87	
			24MHz	4.92	
			16MHz	3.66	
			8MHz	3.19	

(1) Data was derived from a comprehensive evaluation and is not tested in production.

(2) When the external clock is 8MHz and f_{HCMU} >8MHz, it enables PLL.

Table 19. Maximum Current Consumption in Sleep Mode, Code Runs from Flash or RAM

Symbol	Parameters	Conditions	f _{HCLK}	Maximum Value ⁽¹⁾	Unit
				T _A =105°C , V _{DD} =3.6 V	
I _{DD}	Static Current during Sleep Mode	External clock ⁽²⁾ , enabling all peripherals	96 MHz	17.39	mA
			72MHz	13.32	
			48MHz	9.14	
			36MHz	7.11	
			24MHz	5.07	
			16MHz	3.69	
			8MHz	2.31	
		External clock ⁽²⁾ , turn off all peripherals	96 MHz	5.07	
			72MHz	4.06	
			48MHz	3.02	
			36MHz	2.46	
			24MHz	1.99	
			16MHz	1.62	
			8MHz	1.31	

(1) Data was derived from a comprehensive evaluation and is not tested in production.

(2) When the external clock is 8MHz and f_{HCMU} >8MHz, it enables PLL.

Table 20. Maximum Current Consumption in Stop Mode and Standby Mode

Symbol	Parameters	Conditions	Maximum Value ⁽¹⁾	Unit
			T _A =105°C, V _{DD} =3.6 V	
I _{DD}	Supply current in stop mode	Regulator in run mode, low-speed and high-speed internal RC oscillators and high-speed oscillator OFF(no independent watchdog)	94.19	μA
		Regulator in low-power mode, low-speed and high-speed internal RC oscillators and high-speed oscillator OFF(no independent watchdog)	79.18	
	Supply current in standby mode	Low-speed internal RC oscillator and independent watchdog ON	17	
		Low-speed internal RC oscillator is on, independent watchdog OFF	16.82	
		Low-speed internal RC oscillator and independent watchdog OFF, low-speed oscillator and RTC OFF	15.89	
I _{DD_VBAT}	Supply current in the backup area	Low-speed oscillator and RTC ON	3.0	

(1) Data was derived from a comprehensive evaluation and is not tested in production.

Typical Current Consumption

The microcontroller is under the following conditions:

- All I/O pins are in input mode and are connected to a static level $-V_{DD}$ or V_{SS} (no load).
- All peripherals are turned off unless otherwise stated.
- The access time of flash is adjusted to the frequency f_{HCMU} (0~24MHz-0 wait cycles, 24~48MHz-1 wait cycle, 48~72MHz-2 wait cycles, 96MHz-3 wait cycles).
- The instruction prefetch function is turned on (hint: this setting must be made before the clock setting and bus division).

When the peripheral is turned on: $f_{pCMU1} = f_{HCMU}/2$, $f_{pCMU2} = f_{HCMU}$.

Table 21. Run-mode current consumption, code with data processing running from internal Flash

Symbol	Parameter	f_{HCMU}	Typical Value ⁽¹⁾		Unit
			$T_A=25^{\circ}C, V_{DD}=3.3V$		
			External clock ⁽²⁾ , enables all peripherals	External clock ⁽²⁾ , turn off all peripherals	
I_{DD}	Supply current in operation mode	96 MHz	30.94	19.37	mA
		72MHz	25.47	17.22	
		48MHz	19.35	14.08	
		36MHz	14.95	10.67	
		24MHz	11.17	8.32	
		16MHz	7.72	6.01	
		8MHz	4.25	3.28	

(1) Data was derived from comprehensive evaluation and is not tested in production.

(2) When the external clock is 8MHz and $f_{HCMU} > 8MHz$, it enables PLL.

Table 22. Run-mode current consumption, code with data processing running from internal RAM

Symbol	Parameter	f _{HCMU}	Typical Value ⁽¹⁾		Unit
			TA=25°C, VDD=3.3V		
			External clock ⁽²⁾ , enables all peripherals	External clock ⁽²⁾ , turn off all peripherals	
I _{DD}	Supply current in operation mode	96 MHz	27.53	16.42	mA
		72MHz	20.78	12.51	
		48MHz	14.43	8.74	
		36MHz	11.02	6.61	
		24MHz	7.65	4.68	
		16MHz	5.36	3.37	
		8MHz	3.08	3.10	

(1) Data was derived from comprehensive evaluation and is not tested in production.

(2) When the external clock is 8MHz and f_{HCMU} >8MHz, it enables PLL.

Table 23. Typical current consumption in sleep mode, code running from Flash or RAM

Symbol	Parameter	f _{HCMU}	Typical Value ⁽¹⁾		Unit
			TA=25°C, VDD=3.3V		
			External clock ⁽²⁾ , enables all peripherals	External clock ⁽²⁾ , turn off all peripherals	
I _{DD}	Supply current in sleep mode	96 MHz	17.18	5.16	mA
		72MHz	13.03	3.92	
		48MHz	9.11	2.88	
		36MHz	7.06	2.36	
		24MHz	5.01	1.85	
		16MHz	3.67	1.52	
		8MHz	2.25	1.19	

(1) Data was derived from comprehensive evaluation and is not tested in production.

(2) When the external clock is 8MHz and f_{HCMU} >8MHz, it enables PLL.

Table 24. Typical current Consumption in Stop Mode and Standby Mode

Symbol	Parameters	Conditions	Typical Value (T _A =25°C)			Unit
			V _{DD} =2.4 V	V _{DD} =3.3 V	V _{DD} =3.6 V	
I _{DD}	Supply current in stop mode	Regulator in run mode, low-speed and high-speed internal RC oscillators and high-speed oscillator OFF(no independent watchdog)	22.68	24.02	24.22	μA
		Regulator in low-power mode, low-speed and high-speed internal RC oscillators and high-speed oscillator OFF(no independent watchdog)	10.91	11.88	11.93	
	Supply current in standby mode	Low-speed internal RC oscillator and independent watchdog ON	3.61	5.0	5.49	
		Low-speed internal RC oscillator is on, independent watchdog OFF	3.51	4.86	5.32	
		Low-speed internal RC oscillator and independent watchdog OFF, low-speed oscillator and RTC OFF	2.91	3.95	4.30	
	I _{DD_VBAT}	Supply current in the backup area	Low-speed oscillator and RTC ON	1.1	1.4	

(1) Data was derived from a comprehensive evaluation and is not tested in production

5.3.4. External Clock Source Features

High-speed External Clock Generated From Crystal/Ceramic Resonator

The high-speed external(HSECLK) clock can be supplied with a 4 to 16MHz crystal\ceramic resonator oscillator. All the information given in this paragraph are based on characterization results obtained with typical external components specified in Table 25. In the application, the resonator and the load capacitors have to be placed as closed as possible to the oscillator pins in order to minimize output distortion and startup stabilization time. For detailed parameters (frequency, package, accuracy, etc.) of the crystal resonator, please consult the corresponding manufacturer.

Table 25.HSECLK 4~16MHz Oscillator Features⁽¹⁾⁽²⁾

Symbol	Parameters	Conditions	Minimum Value	Typical Value	Maximum Value	Unit
f_{OSC_IN}	Oscillator Frequency:	-	4	8	16	MHz
R_F	Feedback Resistance	-	-	300	-	k Ω
C_{L1} & $C_{L2}^{(3)}$	Recommended load capacitance and corresponding crystal serial impedance (RS) (4)	RS = 30k Ω	-	30	-	pF
i_2	HSECLK drive current	$V_{DD}=3.3V$, $V_{IN}=V_{SS}$ 30pF load	-	-	1.1	mA
g_m	Oscillator transconductance	Startup	6.17	-	-	mA/V
$t_{SU(HSECLK)}^{(5)}$	Startup Time	V_{DD} is stable	-	1.33	-	ms

- (1) The features parameters of the resonator are given by the crystal/ceramic resonator manufacturer.
- (2) It is derived from a comprehensive evaluation and is not tested in production.
- (3) For C_{L1} and C_{L2} , it is recommended to use high quality ceramic capacitors (typically) between 5pF and 25pF for high frequency applications. Select the capacitor value to meet the requirements of the crystal or resonator. Usually C_{L1} and C_{L2} have the same parameters. Crystal manufacturers typically give the parameters of the load capacitance in a serial combination of C_{L1} and C_{L2} . When selecting C_{L1} and C_{L2} , the capacitive reactance of the PCB and MCU pins should be taken into account (the pin and PCB capacitance can be roughly estimated at 10pF).
- (4) Relatively low R_F resistance provides protection against problems caused by changes in leakage and bias conditions when used in wet conditions. However, if the MCU is used in a harsh wet environment, this factor needs to be taken into account when designing.
- (5) $t_{SU(HSECLK)}$ is the start-up time measured from the moment it is enabled (by software) to a stabilized 8 MHz oscillation is reached. This value is measured using a standard crystal resonator, which may vary greatly depending on the crystal manufacturer.

Figure 12. Typical application of 8MHz crystal oscillator

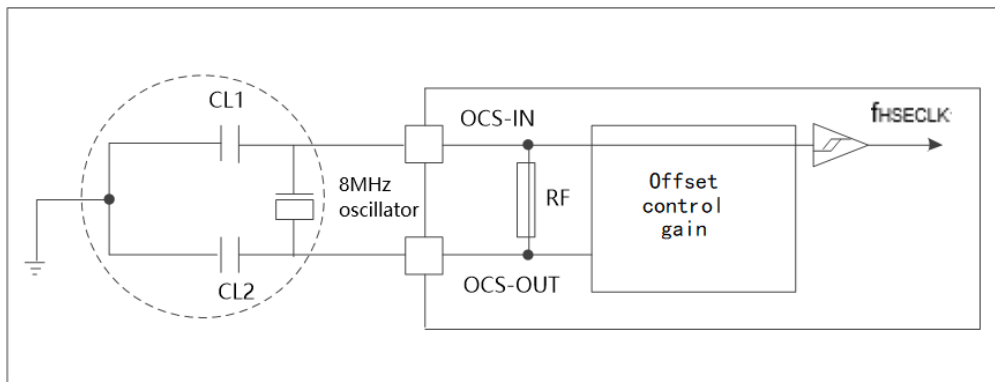

Low-speed External Clock Generated From the Crystal/Ceramic Resonator

The low-speed external(LSECLK) clock can be supplied with a 32.768kHz crystal\ceramic resonator oscillator. All the information given in this paragraph are based on characterization results obtained with typical external components specified in table 26.In the application, the resonator and load capacitors have to be placed as close as possible to the oscillator pins in order to minimize output distortion and startup stabilization time. For detailed parameters (frequency, package, accuracy, etc.) of the crystal resonator, please consult the corresponding manufacturer.

Table 26.LSECLK Oscillator Features ($f_{LSECLK} = 32.768\text{KHz}$) ⁽¹⁾

Symbol	Parameters	Conditions	Minimum Value	Typical Value	Maximum Value	Unit
f_{OSC_IN}	Oscillator frequency			32.768		KHz
RF	Feedback Resistance			7		MΩ
C_{L1} & C_{L2} ⁽²⁾	Recommended load capacitance and corresponding crystal serial impedance (R_s) ⁽³⁾	$R_s = 30\text{k}\Omega$			15	pF
i_2	LSECLK drive current	$V_{DD} = 3.3\text{V}$, $V_{IN} = V_{SS}$			1.4	μA
$t_{SU(LSECLK)}$ ⁽⁴⁾	Start Time	V_{DD} is stable		2.75		s

- (1) Data was derived from a comprehensive evaluation and is not tested in production.
- (2) See the tips and warnings section below this table.
- (3) Use a high quality oscillator with a small R_s value (such as MSIV-TIN32.768kHz) to optimize current consumption. Please consult the crystal manufacturer for details.
- (4) $t_{SU(HSECLK)}$ is the start-up time measured from the moment it is enabled (by software) to a

stabilized 8 MHz oscillation is reached. This value is measured using a standard crystal resonator, which may vary greatly depending on the crystal manufacturer

Tip: For C_{L1} and C_{L2} , it is recommended to use a high quality ceramic capacitor between 5pF and 15pF and select the capacitance value to meet the requirements of the crystal or resonator. Usually C_{L1} and C_{L2} have the same parameters. Crystal manufacturers typically give the parameters of the load capacitance in a serial combination of C_{L1} and C_{L2} . Load capacitance C_L has the following formula: $C_L = C_{L1} \times C_{L2} / (C_{L1} + C_{L2}) + C_{stray}$ where C_{stray} is the pin capacitance and board or trace PCB-related capacitance, Typically, it is between 2 pF and 7 pF.

Warning: To avoid exceeding the maximum value of C_{L1} and C_{L2} (15 pF) it is strongly recommended to use a resonator with a load capacitance $C_L \leq 7$ pF. Never use a resonator with a load capacitance of 12.5 pF.

Example: if you choose a resonator with a load capacitance of $C_L = 6$ pF, and $C_{stray} = 2$ pF, then $C_{L1} = C_{L2} = 8$ pF

Figure 13. Typical application of 32.768MHz crystal oscillator

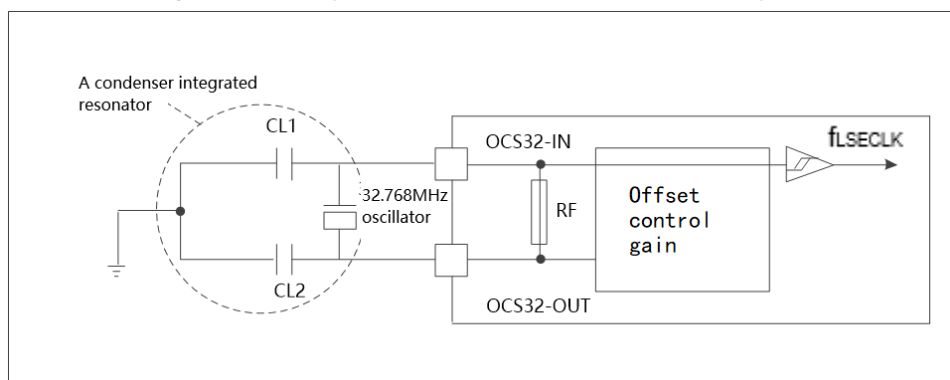

5.3.5. Internal Clock Source Features

High Speed Internal (HSICLK) RC Oscillator Test

Table 27. HSICLK Oscillator Features⁽¹⁾

Symbol	Parameters	Conditions	Minimum Value	Typical Value	Maximum Value	Unit
f_{HSICLK}	Frequency			8		MHz
ACC_{HSICLK}	HSICLK oscillator accuracy	Factory calibration	$T_A = 25^\circ\text{C}$ $V_{DD} = 3.3\text{V}$	1	1	%
			$T_A = -40 \sim 105^\circ\text{C}$ $V_{DD} = 2 \sim 3.6\text{V}$	-2.63	3.56	%
			$T_A = 25^\circ\text{C}$ $V_{DD} = 2 \sim 3.6\text{V}$	-0.88	3.28	%

		User calibration		-1		1	
$t_{SU(HSICLK)}$	HSICLK oscillator startup Time	$V_{DD} = 3.3V$ $T_A = -40\sim 105^{\circ}C$		1.73		2.12	μs
$I_{DD(HSICLK)}$	HSICLK oscillator power consumption	$V_{DD} = 3.6V$ $T_A = -40\sim 105^{\circ}C$					μA

(1) Data was derived from a comprehensive evaluation and is not tested in production
Low Speed Internal (LSICLK) RC Oscillator Test

Table 28.LSICLK Oscillator Features ⁽¹⁾

Symbol	Parameters	Minimum Value	Typical Value	Maximum Value	Unit
f_{LSICLK}	Frequency ($V_{DD} = 2-3.6V$, $T_A = -40\sim 105^{\circ}C$)	30	40	50	KHz
$t_{SU(LSICLK)}$	LSICLK oscillator startup Time ($V_{DD} = 3.3V$, $T_A = -40\sim 105^{\circ}C$)			39	μs
$I_{DD(LSICLK)}$	LSICLK oscillator power consumption ($V_{DD} = 3.6V$, $T_A = -40\sim 105^{\circ}C$)		1	1.5	μA

(1) Data was derived from a comprehensive evaluation and is not tested in production.

Wake Up Time in Low Power Mode

The Time values in the table are all a wake-up clock source from an 8MHz HSICLK RC oscillator and measured during its wake-up phase. The wake-up clock source is determined by current working mode:

- Stop or standby mode: the clock source is the RC oscillator
- Sleep mode: the clock source is the clock set when entering sleep mode

Table 29.Wake Up Time in Low Power Mode

Symbol	Parameters	Typical Value	Unit
$t_{WUSLEEP}^{(1)}$	Wake up from sleep mode	1.2	μs
$t_{WUSTOP}^{(1)}$	Wake up from stop mode (regulator is in running-mode)	3.6	μs
	Wake-up from stop mode (regulator is low power mode)	6	
$t_{WUSTDBY}^{(1)}$	Wake-up from standby mode	32	μs

(1) The wakeup Times are measured from the wakeup event to the point in which the user application code reads the first instruction

5.3.6. PLL Features

Table 30.PLL Features

Symbol	Parameters	Value			Unit
		Minimum Value	Typical Value	Maximum Value (1)	
f _{PLL_IN}	PLL Input clock (2)	2	8	25	MHz
	Input Clock Duty Cycle	40		60	%
f _{PLL_OUT}	PLL multiplier output clock (V _{DD} = 3.3V, T _A = -40~105°C)	16		96	MHz
t _{LOCK}	PLL lock Time			130	μs

(1) Data was derived from a comprehensive evaluation and is not tested in production.

(2) Note that the appropriate multiplication factor is used so that the PLL input clock frequency is consistent with the range determined by f_{PLL_OUT}.

5.3.7. Memory Features

FLASH Memory

Table 31.FLASH Memory Features (1)

Symbol	Parameters	Conditions	Minimum Value	Typical Value	Maximum Value	Unit
t _{prog}	16-bit programming Time	T _A = -40~105°C V _{DD} =2.4~3.6V	17.8	18.6	19.5	μs
t _{ERASE}	Page (1K bytes) erase Time	T _A = -40~105°C V _{DD} =2.4~3.6V	1.34	1.42	1.51	ms
t _{ME}	Whole erase Time	T _A = 25°C V _{DD} =3.3V			6.5	ms
V _{prog}	Programmable voltage	T _A = -40~105°C	2.0	3.3	3.6	V

(1) Data was derived from a comprehensive evaluation and is not tested in production

Table 32.FLASH Memory Life and Data Retention Period

Symbol	Parameters	Conditions	Minimum Value	Typical Value	Maximum Value	Unit
N _{END}	Number of erase cycles	T _A = -40~85°C	100			Thousand Times cycle
t _{RET}	Data Retention Period	T _A = 55°C	20			Years

(1) Data was derived from a comprehensive evaluation and is not tested in production

5.3.8. I/O Ports Features

Input/Output Static Features

Table 33. I/O Static Features (Test conditions $V_{CC}=2.7-3.6V$, $T_A = -40\sim 105^{\circ}C$)

Symbol	Parameters	Conditions	Minimum Value	Typical Value	Maximum Value	Unit
V_{IL}	Low level input voltage	TTL port	-0.5		0.8	V
V_{IH}	Standard I/O pin, input high level voltage		2		$V_{DD}+0.5$	
	FT I/O pin ⁽¹⁾ , input high level voltage		2		5.5	
V_{IL}	Input low level voltage	CMOS port	-0.5		$0.3V_{DD}$	
V_{IH}	Input high level voltage		$0.7V_{DD}$		$V_{DD}+0.5$	
V_{hys}	Standard I/O Schmitt trigger voltage hysteresis ⁽²⁾		150			mV
	FT I/O Schmitt trigger voltage hysteresis ⁽²⁾		$5\%V_{DD}$			mV
I_{lkg}	Input leakage current ⁽³⁾	$V_{SS} \leq V_{IN} \leq V_{DD}$ Standard I/O port			± 1	μA
		$V_{IN} = 5V$, I/O FT			1	
R_{PU}	Weak pull-up equivalent resistance ⁽⁴⁾	$V_{IN} = V_{SS}$	32	40	49	k Ω
R_{PD}	Weak pull-down equivalent resistance ⁽⁴⁾	$V_{IN} = V_{DD}$	32	40	49	k Ω
C_{IO}	I/O pin capacitance			5		pF

- (1) FT = 5V tolerant. To withstand voltages above $V_{DD} + 0.3$, the internal pull-up or pull-down resistors must be turned off.
- (2) The hysteresis voltage of the Schmitt trigger switch level is derived from a comprehensive evaluation and is not tested in production.
- (3) If there is reverse current sinking on adjacent pins, the leakage current may be higher than the maximum.
- (4) The pull-up resistor is designed to be implemented as a true resistor in series with a controllable PMOS/NMOS switch

Output Drive Current Test

The GPIO (General Purpose Input/Output Port) can sink or output up to $\pm 8\text{mA}$ and can sink up to $\pm 20\text{mA}$ (V_{OL}/V_{OH} reduction). In user applications, the number of I/Os capable of driving current must be limited so that the current consumed cannot exceed the absolute maximum rating:

- The sum of the currents sourced by all the I/O on V_{DD} , plus the maximum Run consumption of the MCU sourced on V_{DD} , cannot exceed the absolute maximum rating I_{VDD} .
- The sum of the currents sunk by all the I/O on V_{SS} , plus the maximum Run consumption of the MCU sunk on V_{SS} , cannot exceed the absolute maximum rating I_{VSS} .

Output Voltage Test

Table 34. Output Voltage Features (test conditions $V_{CC}=2.7\text{-}3.6\text{V}$, $T_A = -40\sim 105^\circ\text{C}$)

Symbol	Parameters	Conditions	Minimum Value	Maximum Value	Unit
$V_{OL}^{(1)}$	Output low level, when 8 pins simultaneously sink current	TTL port, $I_{IO} = +8\text{mA}$ $2.7\text{V} < V_{DD} < 3.6\text{V}$		0.4	V
$V_{OH}^{(2)}$	Output high level, when 8 pins simultaneously output current		$V_{DD} - 0.4$		
$V_{OL}^{(1)}$	Output low level, when 8 pins simultaneously sink current	CMOS port, $I_{IO} = +8\text{mA}$ $2.7\text{V} < V_{DD} < 3.6\text{V}$		0.4	V
$V_{OH}^{(2)}$	Output high level, when 8 pins simultaneously output current		2.4		
$V_{OL}^{(1)(3)}$	Output low level, when 8 pins simultaneously sink current	$I_{IO} = +20\text{mA}$ $2.7\text{V} < V_{DD} < 3.6\text{V}$		1.3	V
$V_{OH}^{(2)(3)}$	Output high level, when 8 pins simultaneously output current		$V_{DD} - 1.3^{(4)}$		

- (1) The current I_{IO} absorbed by I/O must always follow the absolute maximum rating requirements, while the sum of the I_{IO} s (all I/O and control pins) must not exceed I_{VSS} .
- (2) The current I_{IO} of the I/O output must always follow the absolute maximum rating requirements, while the sum of the I_{IO} s (all I/O and control pins) must not exceed I_{VDD} .
- (3) Data was derived from a comprehensive evaluation and is not tested in production.
- (4) The driving capability of PC13-15 is not included in this item. The other PC port specifications are in the voltage range of $3.3\text{V} < V_{DD} < 3.6\text{V}$.

Input and Output AC Features ($T_A = 25^\circ\text{C}$)

Table 35. Input and Output AC Features

MODEx[1:0] Configuration n	Symbol	Parameters	Conditions	Minimum value	Maximum value	Unit
----------------------------------	--------	------------	------------	---------------	---------------	------

MODEx[1:0] Configuration	Symbol	Parameters	Conditions	Minimum value	Maximum value	Unit
10 (2MHz)	$f_{\max(\text{IO})\text{out}}$	Max frequency ⁽²⁾	$C_L = 50 \text{ pF}, V_{DD} = 2\sim 3.6\text{V}$		2	MHz
	$t_{f(\text{IO})\text{out}}$	Output high to low fall Time	$C_L = 50 \text{ pF}, V_{DD} = 2\sim 3.6\text{V}$		50 ⁽³⁾	ns
	$t_{r(\text{IO})\text{out}}$	Output low to high rise Time			50 ⁽³⁾	
01 (10MHz)	$f_{\max(\text{IO})\text{out}}$	Max frequency ⁽²⁾	$C_L = 50 \text{ pF}, V_{DD} = 2\sim 3.6\text{V}$		10	MHz
	$t_{f(\text{IO})\text{out}}$	Output high to low fall Time	$C_L = 50 \text{ pF}, V_{DD} = 2\sim 3.6\text{V}$		24 ⁽³⁾	ns
	$t_{r(\text{IO})\text{out}}$	Output low to high rise Time			23	
11 (50MHz)	$f_{\max(\text{IO})\text{out}}$	Max frequency ⁽²⁾	$C_L = 30 \text{ pF}, V_{DD} = 2.7\sim 3.6\text{V}$		48	MHz
	$t_{f(\text{IO})\text{out}}$	Output high to low fall Time	$C_L = 30 \text{ pF}, V_{DD} = 2.7\sim 3.6\text{V}$		7 ⁽³⁾	ns
	$t_{r(\text{IO})\text{out}}$	Output low to high rise Time			5 ⁽³⁾	

- (1) The speed of the I/O port can be configured by MODEx[1:0].
- (2) The maximum frequency is defined in the figure below.
- (3) It is guaranteed from design and is not tested in production

Figure 14. Input and Output AC Features Definition

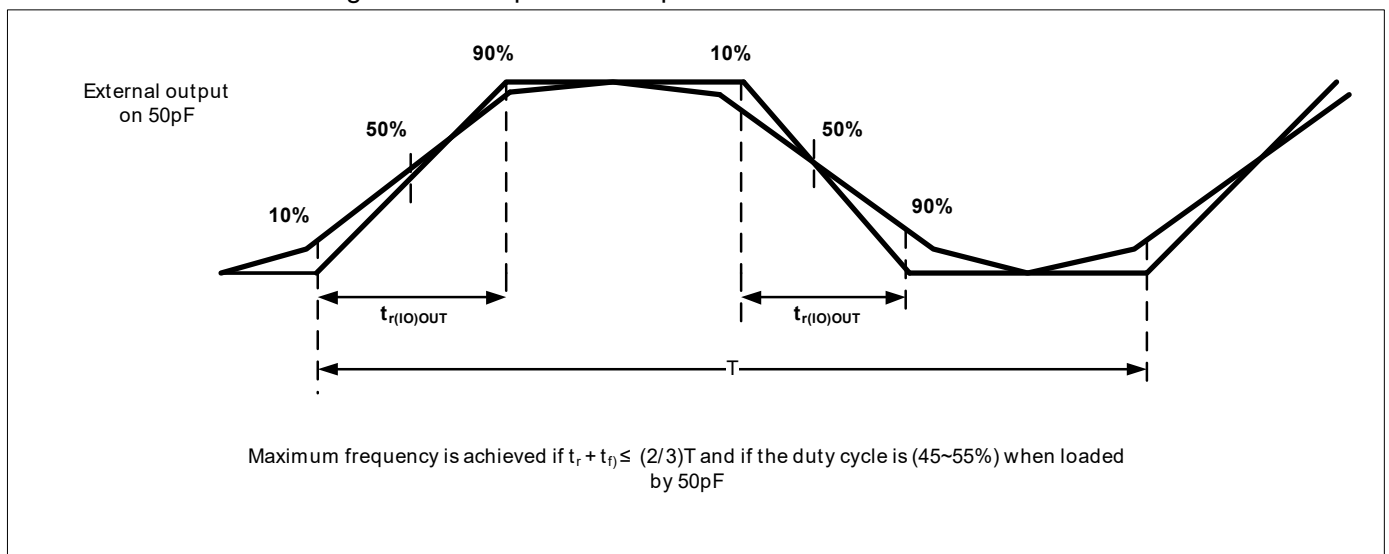

5.3.9. NRST Pins Features

The NRST pin input driver is implemented in a CMOS process that is connected to a permanent pull-up resistor, R_{PU} .

Table 36. NRST NRST Pin Features (Test condition $V_{CC}=3.3V, T_A = -40\sim 105^{\circ}C$)

Symbol	Parameters	Conditions	Minimum Value	Typical Value	Maximum Value	Unit
$V_{IL(NRST)}^{(1)}$	NRST input low level voltage		-0.5		0.8	V
$V_{IH(NRST)}^{(1)}$	NRST input high level voltage		2		$V_{DD}+0.5$	
$V_{hys(NRST)}$	NRST Schmitt trigger voltage hysteresis			300		mV
R_{PU}	Weak pull-up equivalent resistance ⁽²⁾	$V_{IN} = V_{SS}$	32	40	49	k Ω

(1) Data is guaranteed from design, and is not tested in production.

(2) The pull-up resistor is implemented by a pure resistor in series with a turn-off PMOS/NMOS transistor. The PMOS/NMOS switch has a small resistance

5.3.10. Communication Interface I²C Interface Features

Table 37. I²C Interface Features (Test conditions $V_{DD} = 3.3V, T_A = 25^{\circ}C$)

Symbol	Parameters	Standard I ² C ⁽¹⁾		Fast I ² C ^{(1) (2)}		Unit
		Minimum Value	Maximum Value	Minimum Value	Maximum Value	
$t_{w(SCL)}$	SCL clock low Time	5.05		1.72		μs
$t_{w(SCLH)}$	SCL clock high Time	4.94		0.77		
$t_{su(SDA)}$	SDA setup Time	4532		1216		ns
$t_{h(SDA)}$	SDA hold Time	0 ⁽³⁾	503	0 ⁽⁴⁾	459 ⁽³⁾	
$t_{r(SDA)}$ $t_{r(SCL)}$	Rise Time for SDA and SCL		197		190	
$t_{f(SDA)}$ $t_{f(SCL)}$	Fall Time for SDA and SCL		8		9.8	
$t_{h(STA)}$	Start condition hold Time	4.97		0.82		μs
$t_{su(STA)}$	Repeated start condition	4.93		0.81		

Symbol	Parameters	Standard I ² C ⁽¹⁾		Fast I ² C ^{(1) (2)}		Unit
		Minimum Value	Maximum Value	Minimum Value	Maximum Value	
	setup Time					
$t_{su(STO)}$	Stop condition setup Time	4.91		0.82		μs
$t_w(STO:STA)$	Stop to Start condition Time (bus free)	5.27		4.02		μs

- (1) It is guaranteed from design, and is not tested in production.
- (2) For the bit to reach the maximum frequency of the standard mode I2C, fPCMU1 must be greater than 2MHz. To achieve the maximum frequency of fast mode I2C, fPCMU1 must be greater than 4MHz.
- (3) If you do not want to stretch the low Time of the SCL signal, the maximum hold Time of the start condition must be met.
- (4) In order to cross the undefined area of the falling edge of SCL, the SDA signal must be guaranteed to have a hold Time of at least 300 ns inside the MCU.

Figure 15. Bus AC Waveform and Measurement Circuit ⁽¹⁾

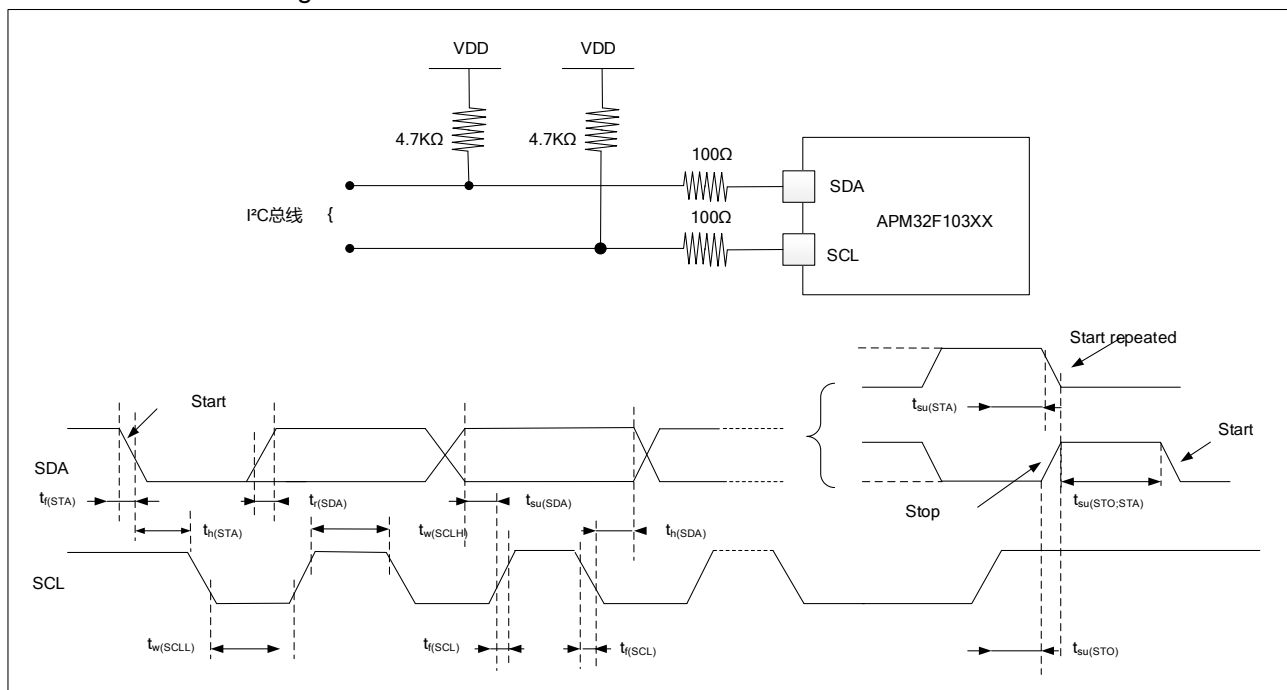

- (1) Measured points are done at CMOS levels: 0.3 V_{DD} and 0.7 V_{DD}.

SPI Interface Features

Table 38.SPI Features ($V_{DD}= 3.3V$, $T_A=25^{\circ}C$)

Symbol	Parameters	Conditions	Minimum Value	Maximum Value	Unit
f_{SCK} $1/t_{c(SCK)}$	SPI Clock Frequency	Master mode		18	MHz
		Slave Mode		18	
$t_{r(SCK)}$ $t_{f(SCK)}$	SPI clock rise and fall Times	Load capacitance: C=30pF		7.1	ns
$t_{su(NSS)}^{(2)}$	NSS setup Time	Slave mode $f_{PCMU} = 36MHz$	111.4		ns
$t_{h(NSS)}^{(2)}$	NSS hold Time	Slave mode $f_{PCMU} = 36MHz$	55.6		ns
$t_{w(SCKH)}^{(2)}$ $t_{w(SCKL)}^{(2)}$	SCK high and low Time	Master mode, $f_{PCMU} = 36MHz$, presc=4	55.1	55.9	ns
$t_{su(MI)}^{(2)}$ $t_{su(SI)}^{(2)}$	Data input setup Time	Master mode	10.9		ns
		Slave mode	21.3		
$t_{h(MI)}^{(2)}$ $t_{h(SI)}^{(2)}$	Data input hold Time	Master Mode	35		ns
		Slave Mode	25		
$t_{a(SO)}^{(2)(3)}$	Data output access Time	Slave mode, $f_{PCLK} = 20MHz$	6.5	8.7	ns
$t_{dis(SO)}^{(2)(4)}$	Data output disable Time	Slave mode	12		ns
$t_{v(SO)}^{(2)(1)}$	Data output valid Time	Slave mode (after enable edge)		19.3	ns
$t_{v(MO)}^{(2)(1)}$	Data output valid Time	Master mode (after enable edge)		7.6	ns
$t_{h(SO)}^{(2)}$	Data output hold Time	Slave mode (after enable edge)	10.7		ns
$t_{h(MO)}^{(2)}$		Master mode (after enable edge)	2		

- (1) The SPI1 feature of the remap needs further determination.
- (2) It is derived from calculation and is not tested in production.
- (3) The minimum value represents the minimum Time to drive the output, and the maximum value represents the maximum Time at which the data is valid.
- (4) The minimum value represents the minimum Time to turn off the output, and the maximum value represents the maximum Time to place the data line in a high impedance state.

Figure 16. SPI Timing Diagram - Slave Mode and CPHA=0

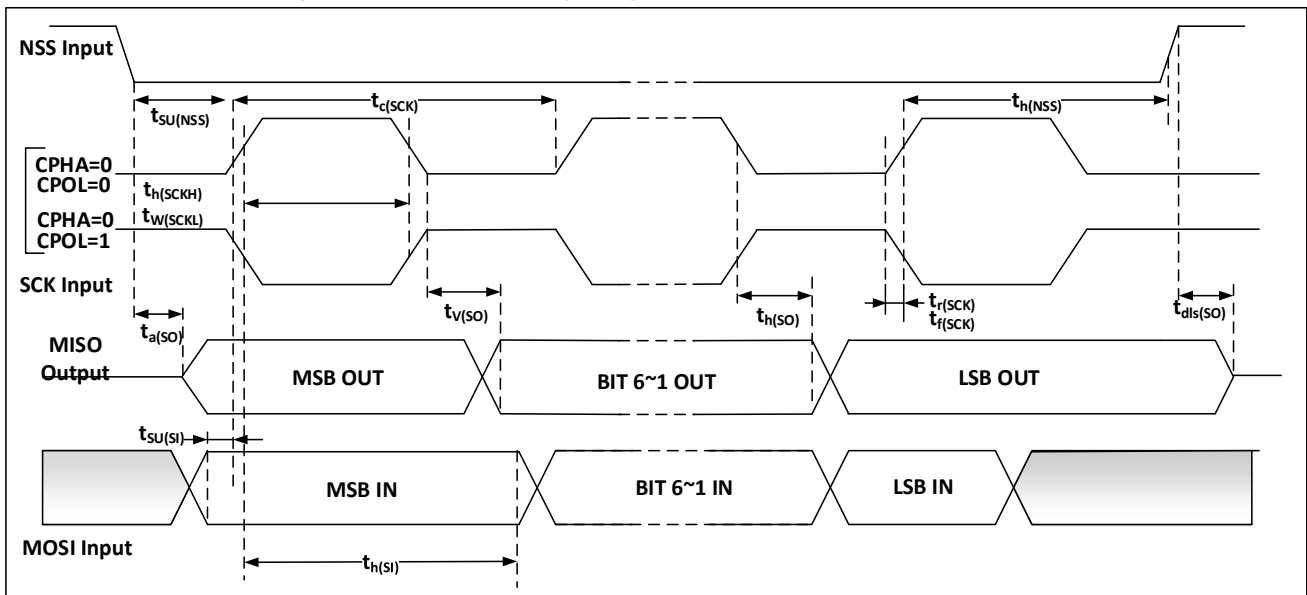
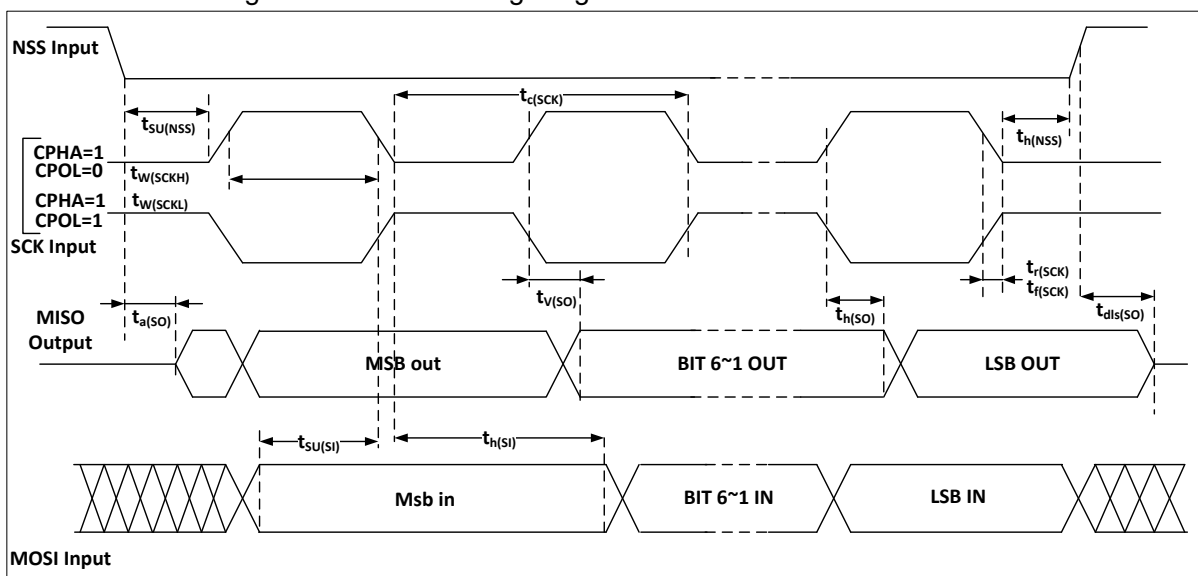
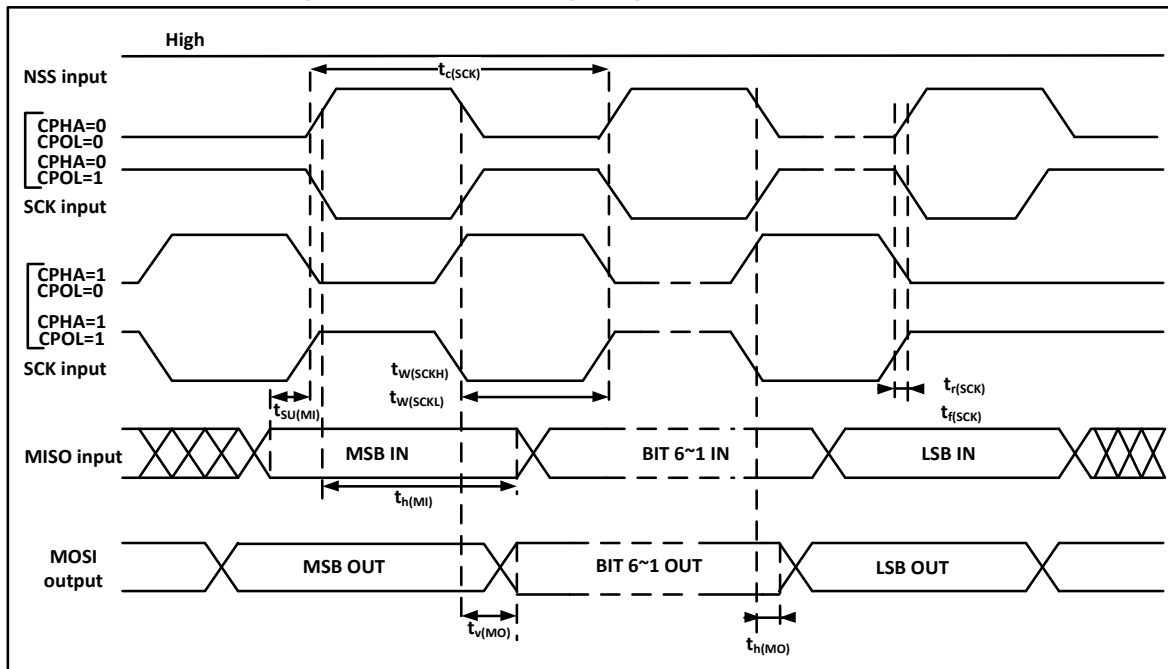

Figure 17. SPI Timing Diagram - Slave Mode and CPHA=1



(1) The measured points are done at CMOS levels: $0.3V_{DD}$ and $0.7V_{DD}$.

Figure 18. SPI Timing Diagram - Master Mode⁽³⁾



(1) The measured points are done at CMOS levels: 0.3V_{DD} and 0.7V_{DD}.

USB Interface Features

Table 39.USB DC Characteristics

Symbol	Parameter	Conditions	Minimum Value ⁽¹⁾	Maximum Value ⁽¹⁾	Unit
Input levels					
V _{DD}	USB operating voltage ⁽²⁾		3.0 ⁽³⁾	3.6	V
V _{DI} ⁽⁴⁾	Differential input sensitivity	I (USBDP, USBDM)	0.2		V
V _{CM} ⁽⁴⁾	Differential common mode threshold	Include V _{DI} range	0.8	2.5	
V _{SE} ⁽⁴⁾	Single ended receiver threshold		1.3	2.0	
Output levels					
V _{OL}	Static output level low	R _L of 1.5kΩ to 3.6V ⁽⁵⁾		0.3	V
V _{OH}	Static output level high	R _L of 1.5kΩ to V _{SS} ⁽⁵⁾	2.8	3.6	

(1) All the voltages are measured from the local ground potential.

- (2) In order to be compatible with USB2.0 full-speed electrical specification, USBDP (D +) pin must pass a 1.5 k Ω resistor connected to the voltage from 3.0 V to 3.6 V.
- (3) The function of APM32F103xx can be guaranteed at 2.7V without the electrical characteristics of degradation in 2.7~ 3.0v voltage range.
- (4) Guaranteed by comprehensive evaluation and is not tested in production.
- (5) RL is the load connected on the USB drivers.

Figure 19. USB Timing: Definition of Data Signal Rise and Fall Times

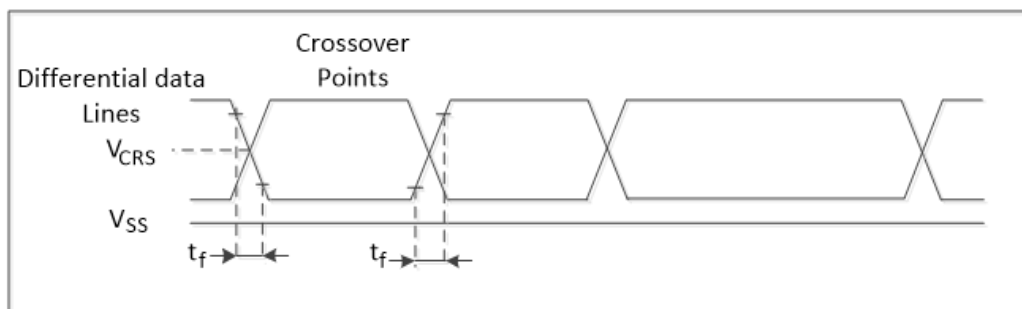

Table 40.USB2 Full-speed Electrical Characteristics

Symbol	Parameters	Conditions	Minimum Value	Maximum Value	Unit
t_r	Rise Time	$C_L = 50\text{pF}$	4.6	9.3	ns
t_f	Fall Time	$C_L = 50\text{pF}$	5.2	10.9	ns
t_{rfm}	Rise&fall Times match	t_r / t_f	71	97	%
V_{CRS}	Crossover voltage of output signal		1.60	2.17	V

5.3.11. 12-bit ADC Features

Table 41.ADC Features ($V_{DD} = 2.4\text{-}3.6\text{V}$, $T_A = -40\sim 105^\circ\text{C}$)

Symbol	Parameters	Conditions	Minimum Value	Typical Value	Maximum Value	Unit
V_{DDA}	Power supply		2.4		3.6	V
V_{REF+}	Positive reference voltage		2.4		V_{DDA}	V
I_{VREF}	Current on V_{REF+} input pin			260	484	μA
f_{ADC}	ADC clock frequency		0.6		14	MHz
f_s	Sampling rate		0.05		1	MHz
V_{AIN}	Conversion voltage range		0		V_{REF+}	V
t_{CAL}	Calibration Time	$f_{ADC} = 14\text{MHz}$	5.9			μs

Symbol	Parameters	Conditions	Minimum Value	Typical Value	Maximum Value	Unit
			83			1/f _{ADC}
R _{ADC}	Sampling resistor		1			kΩ
C _{ADC}	Sample and hold capacitor		12			Pf
t _s	Sampling Time	f _{ADC} = 14MHz	0.107		17.1	μs
			1.5		239.5	1/f _{ADC}
t _{CONV}	Total conversion Time (includes sampling Time)	f _{ADC} = 14MHz	1		18	μs
			14~252(t _s for sampling + 12.5 for successive approximation)			1/f _{ADC}

- (1) Guaranteed by comprehensive evaluation and is not tested in production.
- (2) C_{parasitic} must be added to CAIN. It represents the capacitance of the PCB (dependent on soldering and PCB layout quality) plus the pad capacitance (3 pF). A high C_{parasitic} value will downgrade conversion accuracy. To remedy this, f_{ADC} should be reduced.

Figure 20. Typical application of ADC

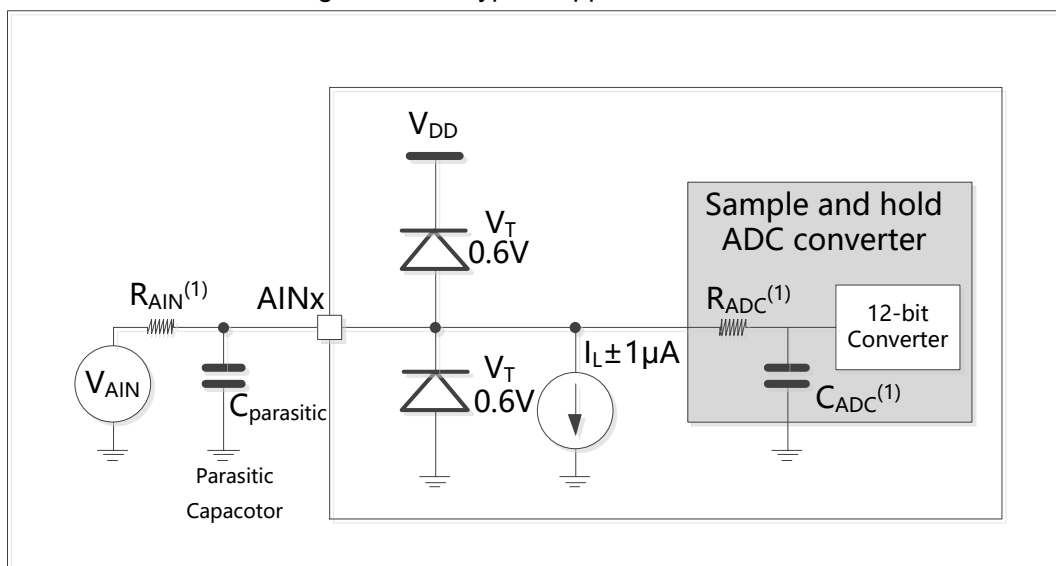

The formula for calculating the maximum external input impedance is as follows:

Formula 1: formula of maximum R_{AIN}

$$R_{AIN} < \frac{T_s}{f_{ADC} \times C_{ADC} \times \ln(2^{N+2})} - R_{ADC}$$

f_{ADC}=14MHZ, C_{ADC}=12PF(Table 41), R_{ADC}=1kΩ(Table 41). Under the requirement of 0.25LSB sampling error accuracy, the relation between T_s and R_{AIN} is shown in the following table:

Table 42.Maximum R_{AIN} at f_{ADC}=14MHZ ⁽¹⁾

TS (cycle)	t_s (μs)	Maximum R_{AIN} ($k\Omega$)
1.5	0.11	4.5
7.5	0.54	26.6
13.5	0.96	48.7
28.5	2.04	103.9
41.5	2.96	151.7
55.5	3.96	203.2

(1) Data is guaranteed from design and is not tested in production.

Table 43.ADC Accuracy

Symbol	Parameter	Conditions	Typical value	Maximum value ⁽³⁾	Unit
ET	Total error	$f_{PCLK2}=56MHz,$ $f_{ADC}=14MHz, R_{AIN}<10K\Omega,$ $V_{DDA}=2.4\sim 3.6V, T_A=-40\sim 105^\circ C$ Measurement was made after the ADC calibration	± 2.5	± 5.5	LSB
Eo	Offset error		± 2.1	± 3.5	
EG	Gain error		± 2.0	± 4	
ED	Differential linearity error		± 1.5	± 2.5	
EL	Integral linearity error		± 1.8	± 3	

(1) DC accuracy value of ADC is measured after internal calibration

(2) ADC Accuracy vs. Negative Injection Current: Injecting negative current on any of the standard analog input pins should be avoided as this significantly reduces the accuracy of the conversion being performed on another analog input. It is recommended to add a Schottky diode (pin to ground) to standard analog pins which may potentially inject negative current.

Any positive injection current within the limits specified for $I_{INJ(PIN)}$ and $I_{INJ(PIN)}$ in Section 5.3.32 does not affect the ADC accuracy.

(3) Guaranteed by comprehensive evaluation and is not tested in production.

Figure 21. ADC Accuracy Characteristics

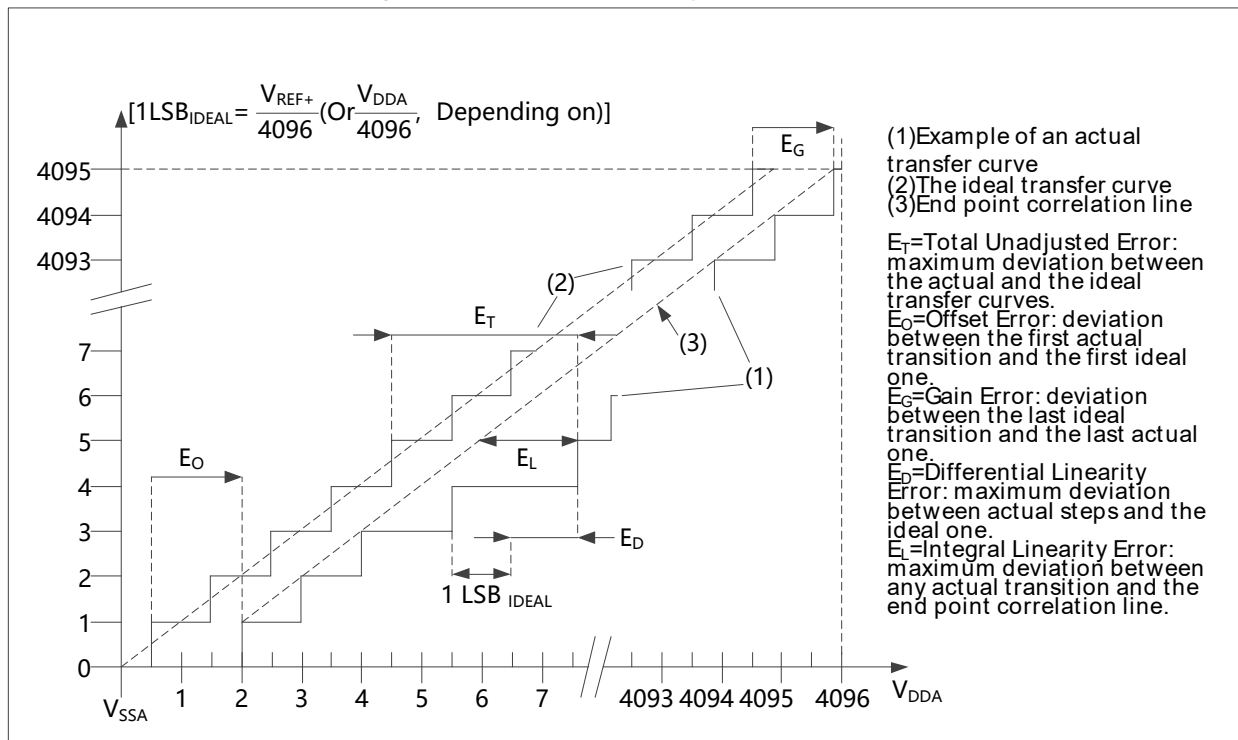

5.3.12. Temperature Sensor Features

Table 44. Temperature Sensor Features

Symbol	Parameters	Minimum Value	Typical Value	Maximum Value	Unit
Avg_Slope ⁽¹⁾	Average slope ($V_{DD} = 3.3V, T_A = -40\sim 105^\circ C$)	4.1	4.2	4.5	mV/°C
V_{25}	Voltage at 25°C ($V_{DD} = 2.4\sim 3.6V$)	1.38	1.41	1.44	V
$t_{START}^{(2)}$	Setup Time	4		10	μs
$T_{S_temp}^{(2) (3)}$	ADC sampling Time when reading the temperature			17.1	μs

- (1) Data is guaranteed by analysis on features, and is not tested in production.
- (2) Data is guaranteed from design, and is not tested in production.
- (3) The shortest sampling Time can be determined by the application through multiple iterations.

5.3.13. EMC Features

Sensitivity tests are sampled for testing during a comprehensive evaluation on the product.

Electromagnetic Sensitivity (EMS)

When running a simple application (controlling 2 LEDs flashing through the I/O port), the test sample is spurious electromagnetic interference until an error occurs, and LED flashing

indicates an error. The test complies with IEC61000-4-4 standard.

Table 45.EMS Features

Symbol	Parameters	Conditions	Level
V_{FESD}	Voltage limits to be applied on any I/O pin to induce a functional disturbance.	$V_{DD} = 3.3V$, $T_A = +25\text{ }^\circ\text{C}$, $f_{HCLK} = 72\text{MHz}$, complies with IEC 61000-4-2	2B
V_{EFTB}	Fast transit voltage burst limits to be applied through 100 pF on V_{DD} and V_{SS} pins to induce a functional disturbance.	$V_{DD} = 3.3V$, $T_A = +25\text{ }^\circ\text{C}$, $f_{HCLK} = 72\text{MHz}$, complies with IEC 61000-4-4	2B

Electromagnetic Interference (EMI)

Monitor the electromagnetic field emitted by the chip while running a simple application (flashing 2 LEDs through the I/O port). This emission test complies with the SAE J1752/3 standard, which specifies the load on the test board and pins.

Table 46.EMI Features

Symbol	Parameters	Conditions	Detection frequency band	Maximum value (f_{HSECLK}/f_{HCMU})		Unit
				8/36MHz	8/96MHz	
SEMI	Peak	$V_{DD} = 3.3V$, $T_A = +25\text{ }^\circ\text{C}$, LQFP100 package	30-230MHz	PASS	PASS	dB μ V
			130MHz-1GHz	PASS	PASS	

6. Packaging Information

6.1. LQFP100 Package Diagram

Figure 22. LQFP100 Package Diagram

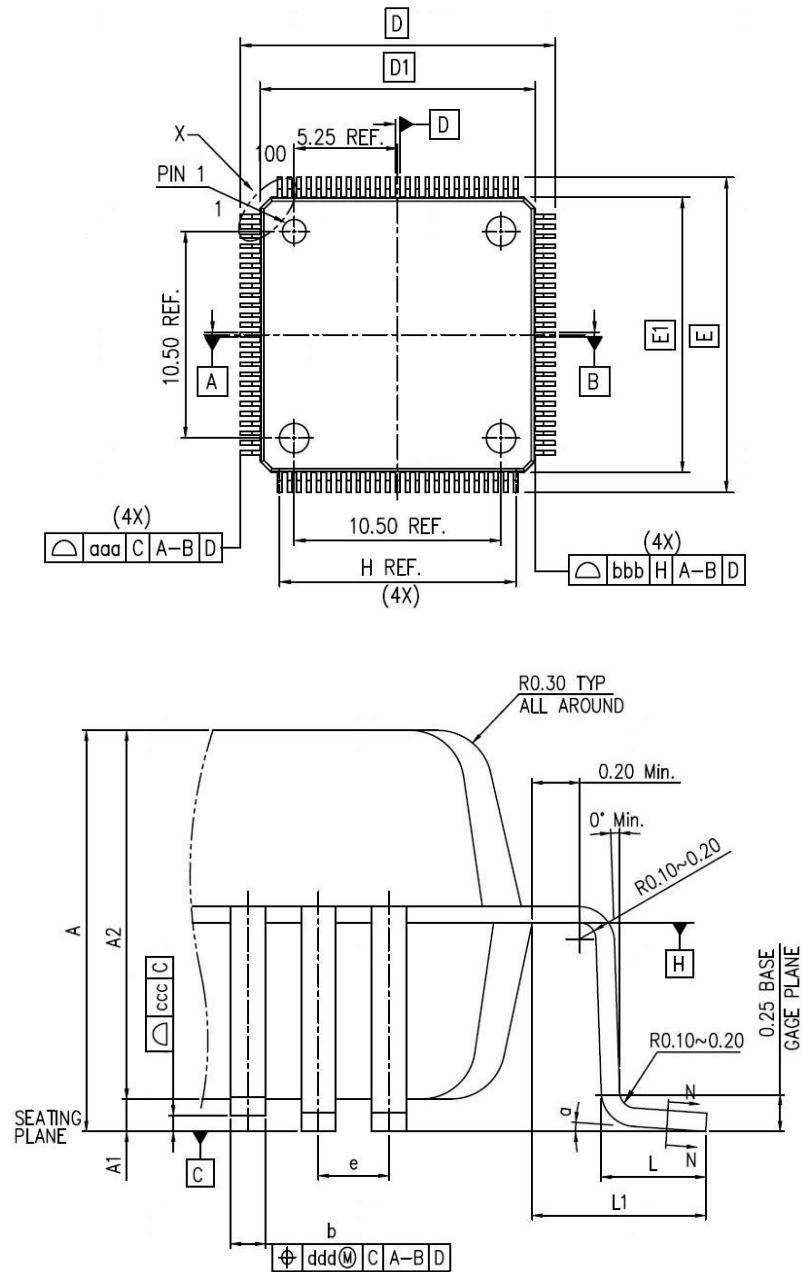

- (1) Drawing is not to scale.
- (2) The inside of the pad on the back is not connected to V_{SS} or V_{DD} .
- (3) There is a pad on the bottom of the QPN package that should be soldered to the PCB.
- (4) All pins should be soldered to the PCB.

Table 47.LQFP100 Package Data

DIMENSION LIST(FOOTPRINT: 2.00)			
S/N	SYM	DIMENDIONS	REMARKS
1	A	MAX. 1.60	OVERALL HEIGHT
2	A1	0.1±0.05	STANDOFF
3	A2	1.40±0.05	PKG THICKNESS
4	D	16.00±0.20	LEAD TIP TO TIP
5	D1	14.00±0.10	PKG LENGTH
6	E	16.00±0.20	LEAD TIP TO TIP
7	E1	14.00±0.10	PKG WDTN
8	L	0.60±0.15	FOOT LENGTH
9	L1	1.00 REF	LEAD LENGTH
10	T	0.15	LEAD THICKNESS
11	T1	0.127±0.03	LEAD BASE METAL THICKNESS
12	a	0°~7°	FOOT ANGLE
13	b	0.22±0.02	LEAD WIDTH
14	b1	0.20±0.03	LEAD BASE METAL WIDTH
15	e	0.50 BASE	LEAD PITCH
16	H(REF.)	(12.00)	CUM. LEAD PITCH
17	aaa	0.2	PROFILE OF LEAD TIPS
18	bbb	0.2	PROFILE OF MOLD SURFACE
19	ccc	0.08	FOOT COPLANARITY
20	ddd	0.08	FOOT POSITION

(1) Dimensions in millimeters

Figure 23. LQFP100-100 pins,14x14mm welding Layout proposal

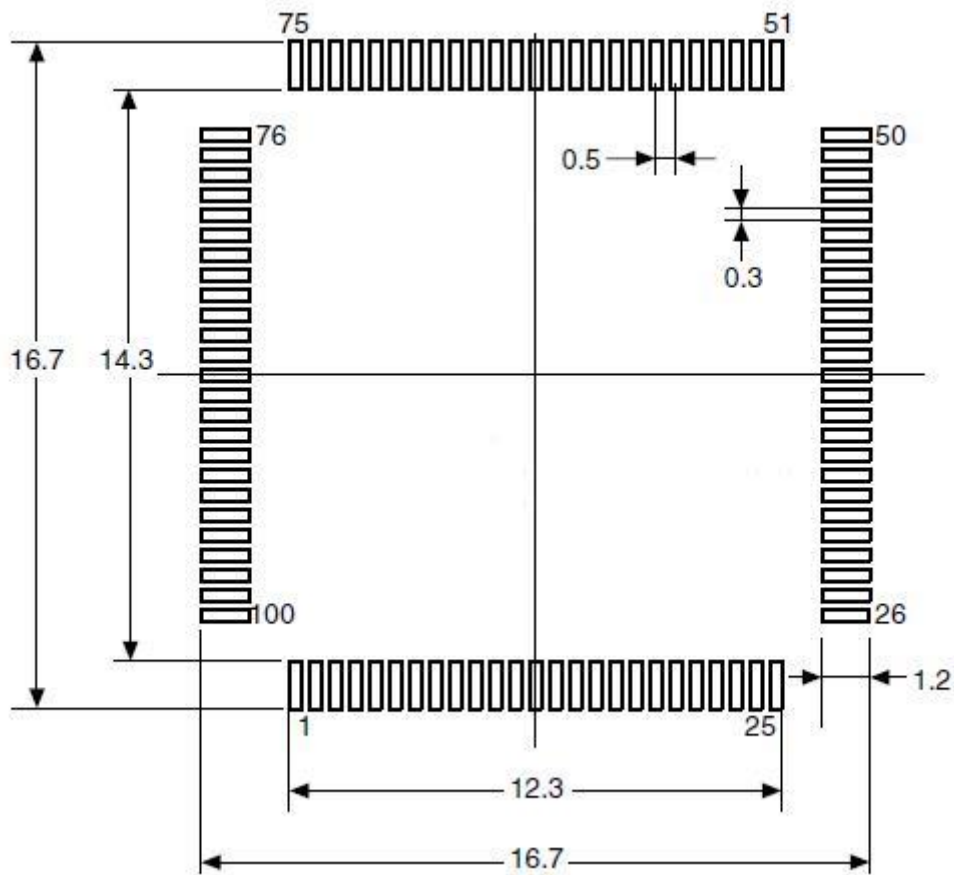

1. Dimensions in millimeters.

Figure 24. LQFP100-100 pin, 14x14mm package identification diagram

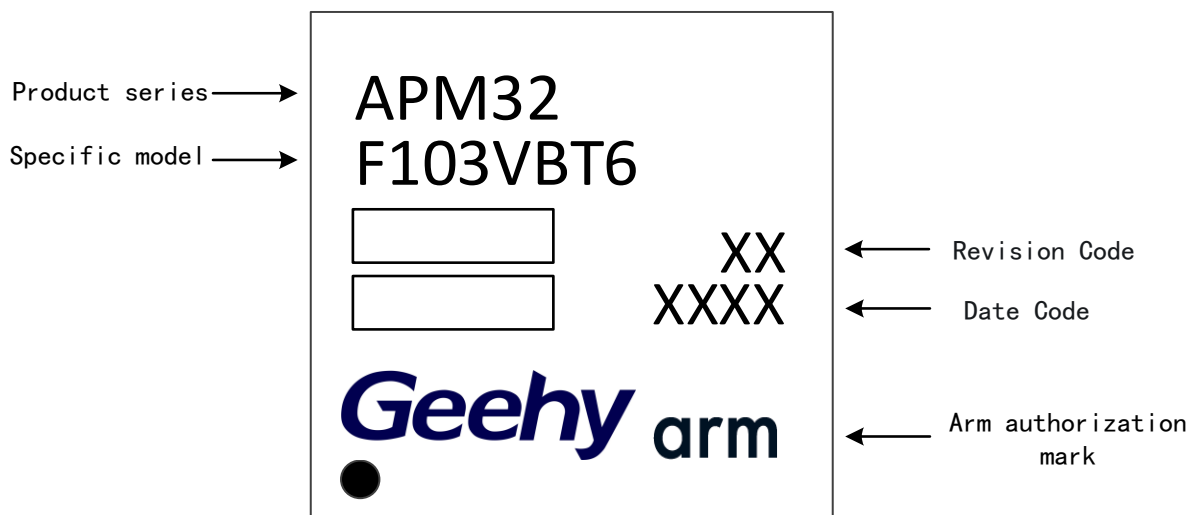

6.2. LQFP64 Package Diagram

Figure 25. LQFP64 Package Diagram

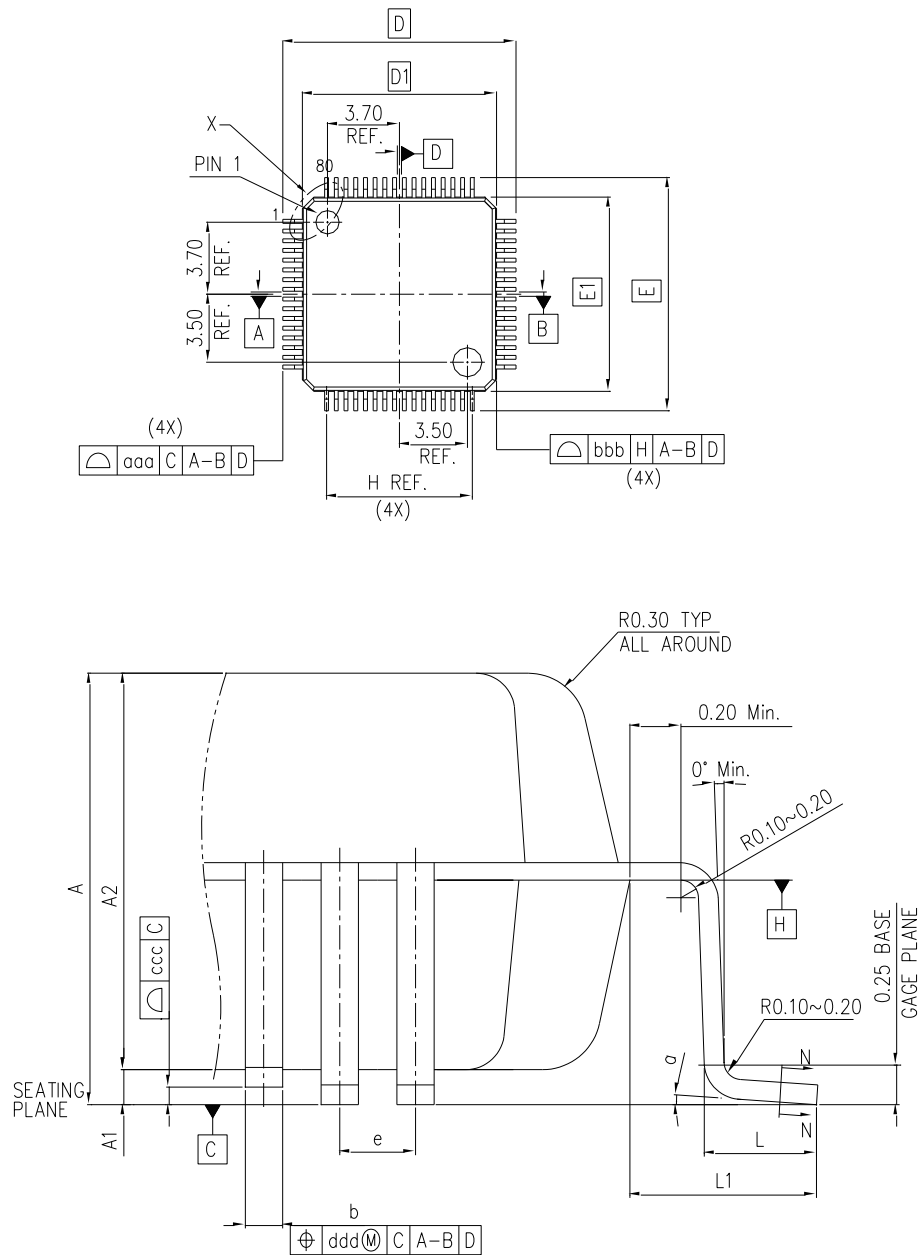

- (1) Drawing is not to scale.
- (2) The inside of the pad on the back is not connected to VSS or VDD.
- (3) There is a pad on the bottom of the QPN package that should be soldered to the PCB.
- (4) All pins should be soldered to the PCB.

Table 48.LQFP64 Package Data

DIMENSION LIST(FOOTPRINT: 2.00)			
S/N	SYM	DIMENDIONS	REMARKS
1	A	MAX. 1.600	OVERALL HEIGHT
2	A1	0.100±0.050	STANDOFF
3	A2	1.400±0.050	PKG THICKNESS
4	D	12.000±0.200	LEAD TIP TO TIP
5	D1	10.000±0.100	PKG LENGTH
6	E	12.000±0.200	LEAD TIP TO TIP
7	E1	10.000±0.100	PKG WDTH
8	L	0.600±0.150	FOOT LENGTH
9	L1	1.000 REF	LEAD LENGTH
10	T	0.150	LEAD THICKNESS
11	T1	0.127±0.030	LEAD BASE METAL THICKNESS
12	a	0°~7°	FOOT ANGLE
13	b	0.220±0.050	LEAD WIDTH
14	b1	0.200±0.030	LEAD BASE METAL WIDTH
15	e	0.500 BASE	LEAD PITCH
16	H(REF.)	(7.500)	CUM. LEAD PITCH
17	aaa	0.2	PROFILE OF LEAD TIPS
18	bbb	0.2	PROFILE OF MOLD SURFACE
19	ccc	0.08	FOOT COPLANARITY
20	ddd	0.08	FOOT POSITION

(1) Dimensions in millimeters.

Figure 26. LQFP64-64 pin, 10x10mm welding Layout proposal

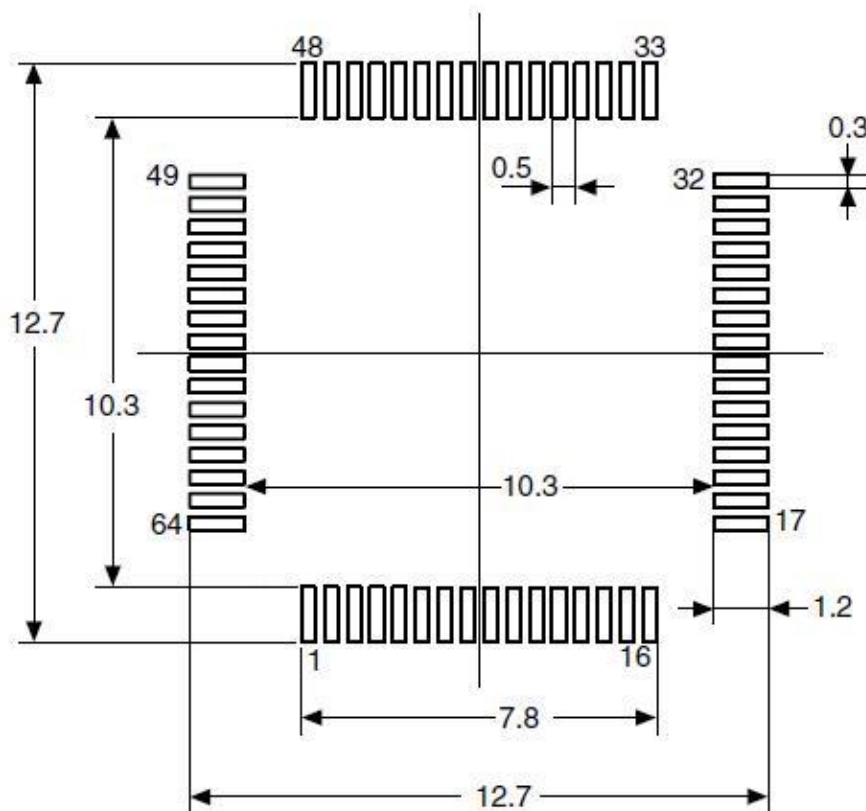

(1) Dimensions in millimeters.

Figure 27. LQFP64-64 pin, 10x10mm package identification diagram

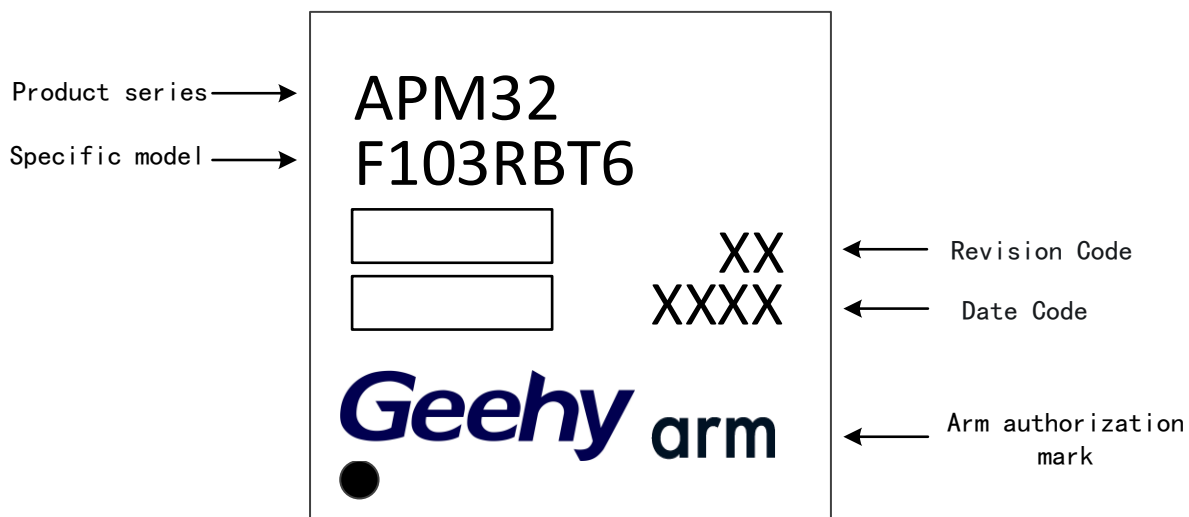

6.3. LQFP48 Package Diagram

Figure 28. LQFP48 Package Diagram

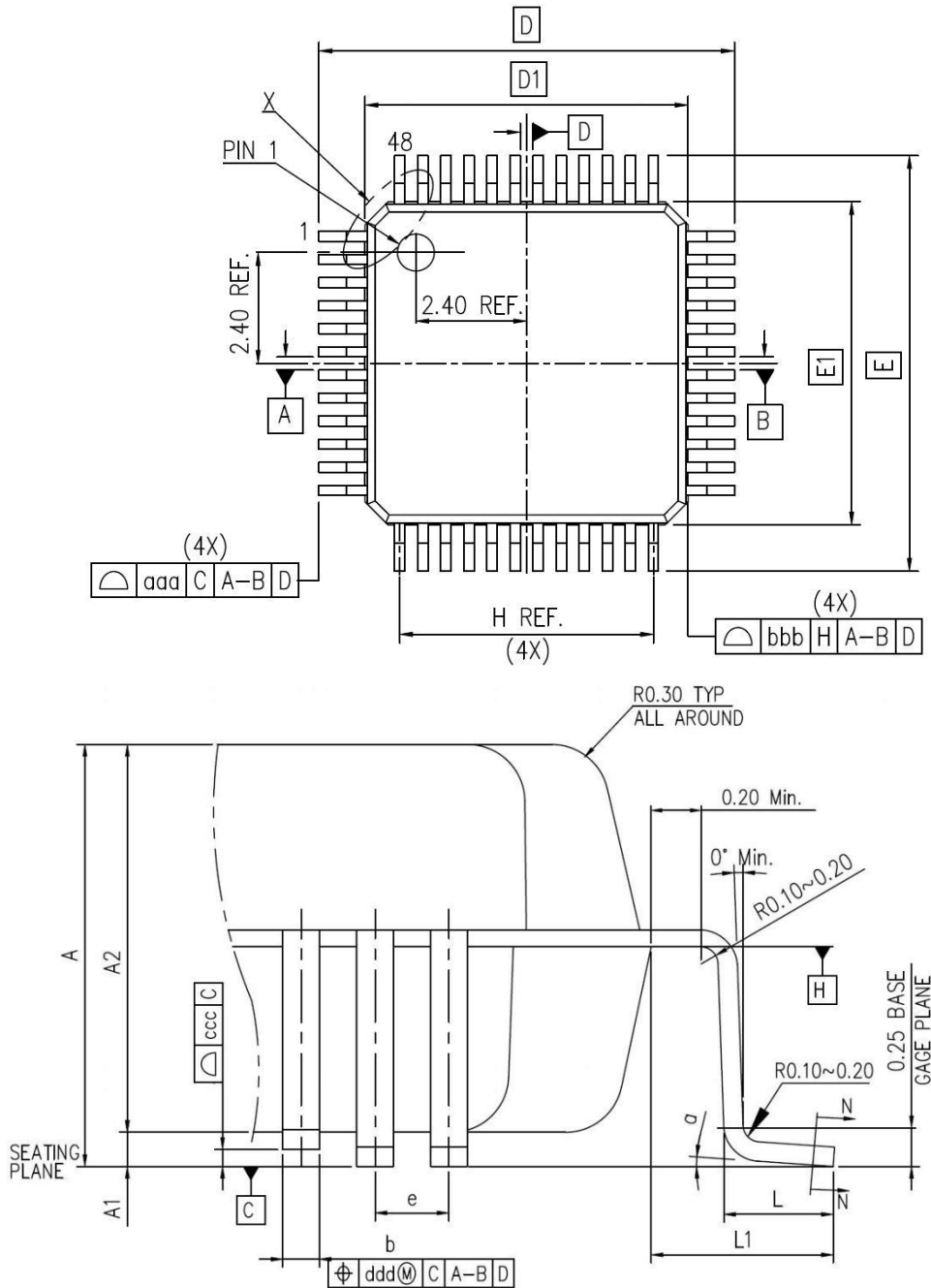

- (1) Drawing is not to scale.
- (2) The inside of the pad on the back is not connected to VSS or VDD.
- (3) There is a pad on the bottom of the QPN package that should be soldered to the PCB.
- (4) All pins should be soldered to the PCB.

Table 49.LQFP Package Data

DIMENSION LIST(FOOTPRINT: 2.00)			
S/N	SYM	DIMENDIONS	REMARKS
1	A	MAX. 1.60	OVERALL HEIGHT
2	A1	0.1±0.05	STANDOFF
3	A2	1.40±0.05	PKG THICKNESS
4	D	9.00±0.20	LEAD TIP TO TIP
5	D1	7.00±0.10	PKG LENGTH
6	E	9.00±0.20	LEAD TIP TO TIP
7	E1	7.00±0.10	PKG WDTN
8	L	0.60±0.15	FOOT LENGTH
9	L1	1.00 REF	LEAD LENGTH
10	T	0.15	LEAD THICKNESS
11	T1	0.127±0.03	LEAD BASE METAL THICKNESS
12	a	0°~7°	FOOT ANGLE
13	b	0.22±0.02	LEAD WIDTH
14	b1	0.20±0.03	LEAD BASE METAL WIDTH
15	e	0.50 BASE	LEAD PITCH
16	H(REF.)	(5.50)	CUM. LEAD PITCH
17	aaa	0.2	PROFILE OF LEAD TIPS
18	bbb	0.2	PROFILE OF MOLD SURFACE
19	ccc	0.08	FOOT COPLANARITY
20	ddd	0.08	FOOT POSITION

(1) dimensions in millimeters。

Figure 29. LQFP48-48 pin,7x7mm welding Layout proposal

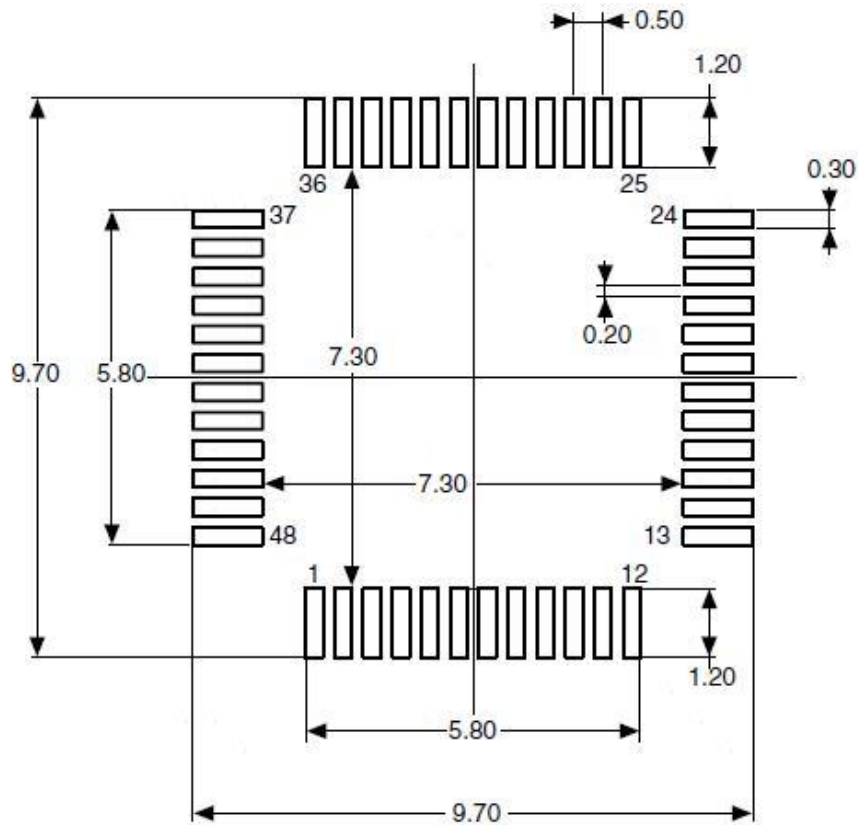

(1) Dimensions in millimeters.

Figure 30. LQFP48-48 pin,7x7mm identification diagram

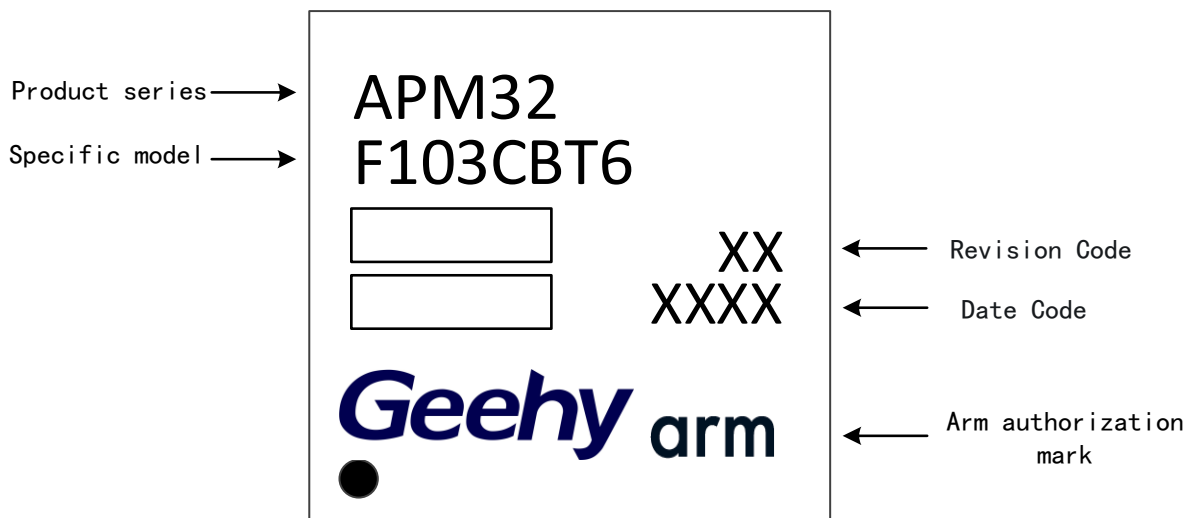

6.4. QFN36 Package Diagram

Figure 31. QFN36 Package Diagram

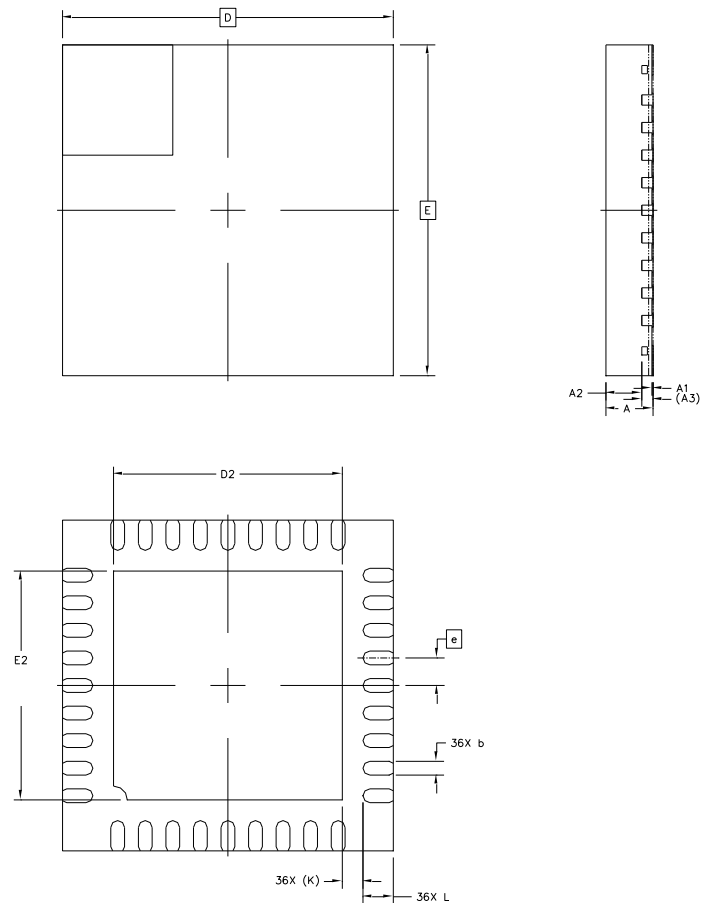

- (1) Drawing is not to scale.
- (2) The inside of the pad on the back is not connected to V_{SS} or V_{DD} .
- (3) There is a pad on the bottom of the QFN package that should be soldered to the PCB.
- (4) All pins should be soldered to the PCB.

Table 50.QFN36 Package Data

		SYMBOL	MIN	NOD	MAX
TOTAL THCKNESS		A	0.8	0.85	0.9
STANO OFF		A1	0	0.02	0.05
MOLO THCKNESS		A2	---	0.65	---
L/F THCKNESS		A3	0.203REF		
LEAD WIDTH		b	0.2	0.25	0.3
BOOY SIZE	X	D	6 BSC		
	Y	E	6 BSC		
LEAD PITCH		e	0.5 BSC		
EP SIZE	X	D2	4.05	4.15	4.25
	Y	E2	4.05	4.15	4.25
LEAD LENGTH		L	0.45	0.55	0.65
LEAD TIP TO EXPOSE PAD EDGE		k	0.375 REF		
PACKAGE EOGE TOLERANCE		aaa	0.1		
MOLD FLATNESS		ccc	0.1		
COPLANARITY		eee	0.08		
LEAD OFFSET		bbb	0.1		
EXPOSED PAD OFFSET		fff	0.1		

(1) dimensions in millimeters.

Figure 32. QFN36 pin, 6 x 6mm Welding Layout Proposal

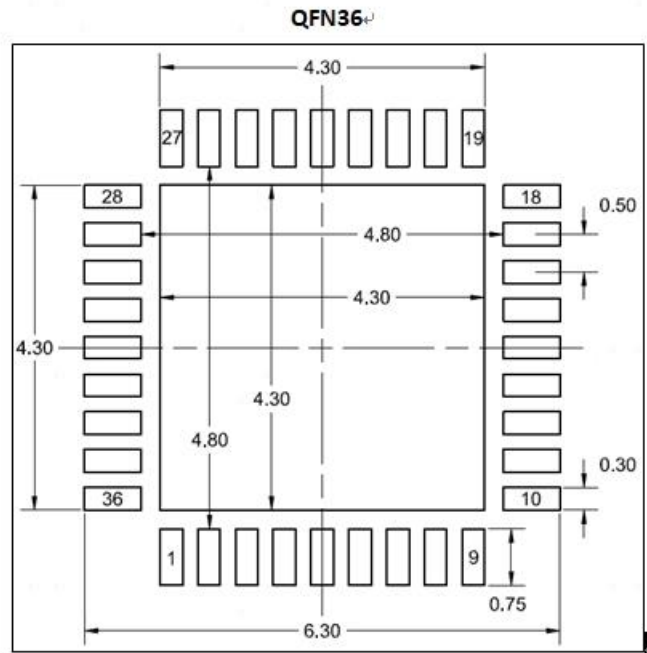

(1) Dimensions in millimeters.

Figure 33. QFN36 pin, 6x6mm identification diagram

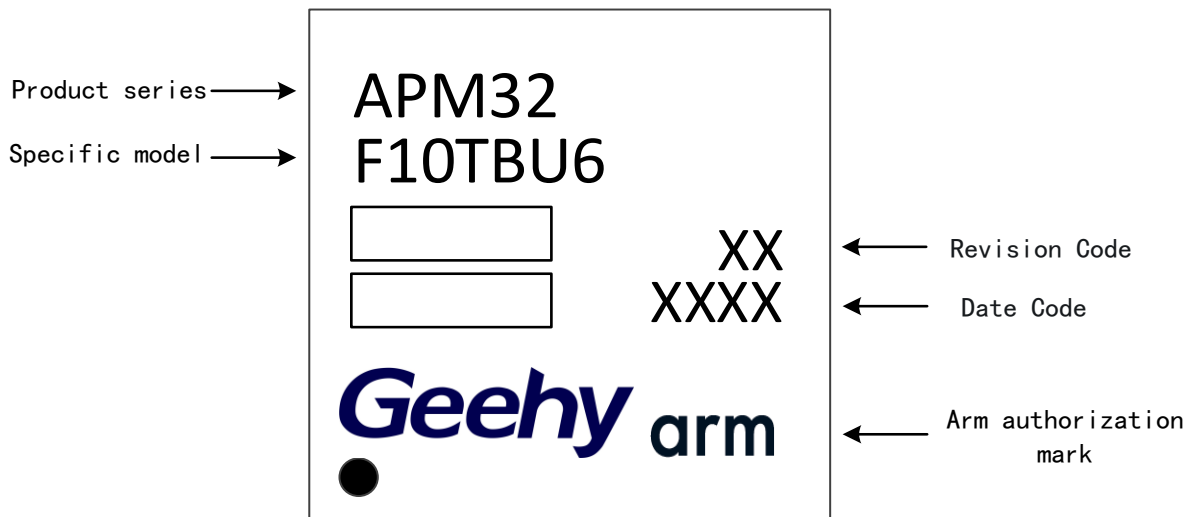

7. Ordering Information

Example:

APM32 F 103 C B T 6 XXX

Device family

APM32 = Arm-based 32-bit microcontroller

Product type

F = Foundation

Device subfamily

103 = Foundation

Pin count

T = 36 pins
C = 48 pins
R = 64 pins
V = 100 pins

Flash memory size

B = 128 Kbytes of Flash memory

Package

T=LQFP
U=QFN

Temperature range

6 = Industrial temperature range, -40 to 85°C
7 = Industrial temperature range, -40 to 105°C

Options

xxx= programmed parts
R = tape and reel
Blank = tray

Table 51. Ordering Information Table

Oder No.	FLASH(KB)	SRAM(KB)	Package	SPQ	Temperature range
APM32F103TBU6	128	20	QFN36	4900	industrial level -40°C~85°C
APM32F103CBT6	128	20	LQFP48	2500	industrial level -40°C~85°C
APM32F103RBT6	128	20	LQFP64	1600	industrial level -40°C~85°C
APM32F103VBT6	128	20	LQFP100	900	industrial level -40°C~85°C
APM32F102CBT6	128	20	LQFP48	2500	industrial level -40°C~85°C
APM32F102RBT6	128	20	LQFP64	1600	industrial level -40°C~85°C
APM32F101TBU6	128	20	QFN36	4900	industrial level -40°C~85°C
APM32F101CBT6	128	20	LQFP48	2500	industrial level -40°C~85°C
APM32F101RBT6	128	20	LQFP64	1600	industrial level -40°C~85°C
APM32F101VBT6	128	20	LQFP100	900	industrial level -40°C~85°C
APM32F103TBU6-R	128	20	QFN36	2500	industrial level -40°C~85°C
APM32F103CBT6-R	128	20	LQFP48	2000	industrial level -40°C~85°C
APM32F103RBT6-R	128	20	LQFP64	1000	industrial level -40°C~85°C
APM32F102CBT6-R	128	20	LQFP48	2000	industrial level -40°C~85°C
APM32F102RBT6-R	128	20	LQFP64	1000	industrial level -40°C~85°C
APM32F101TBU6-R	128	20	QFN36	2500	industrial level -40°C~85°C
APM32F101CBT6-R	128	20	LQFP48	2000	industrial level -40°C~85°C
APM32F101RBT6-R	128	20	LQFP64	1000	industrial level -40°C~85°C

note: SPQ: The minimum number of packages.

8. Package Information

Figure 34. Strip Package Specification Diagram

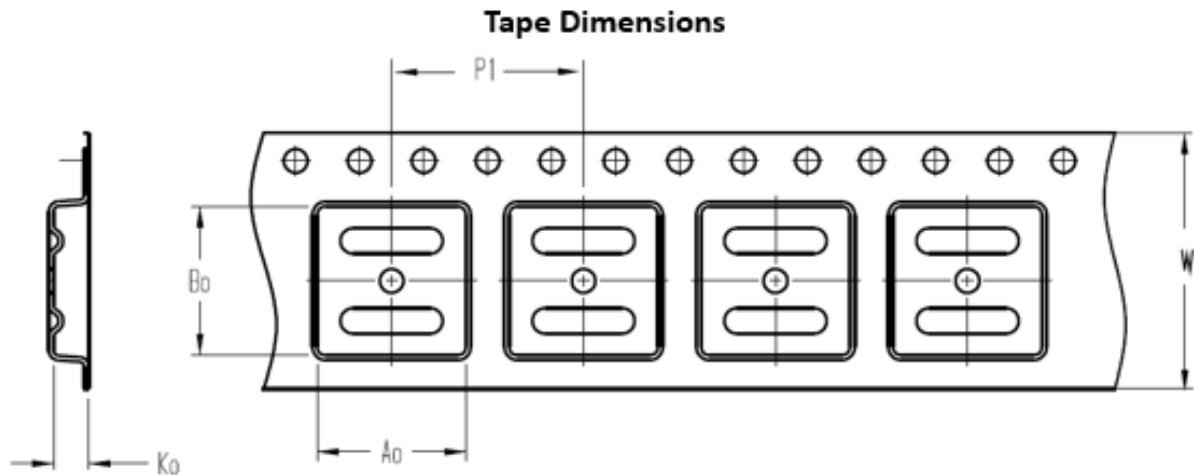

A0	Dimension designed to accommodate the component width
B0	Dimension designed to accommodate the component length
K0	Dimension designed to accommodate the component thickness
W	Overall width of the carrier tape
P1	Pitch between successive cavity centers

Quadrant Assignments For PIN1 Orientation In Tape

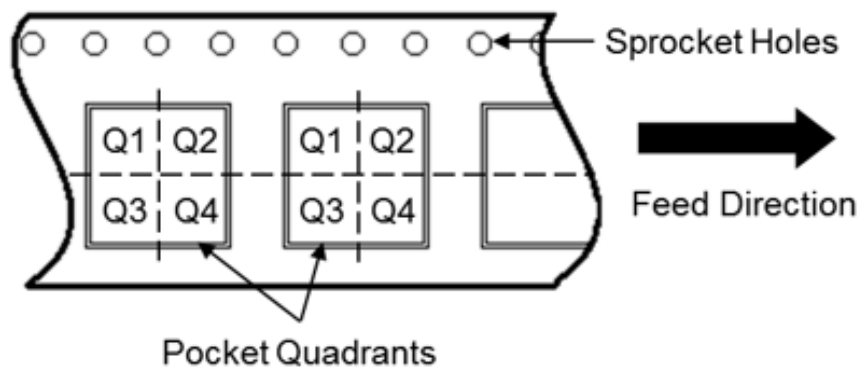

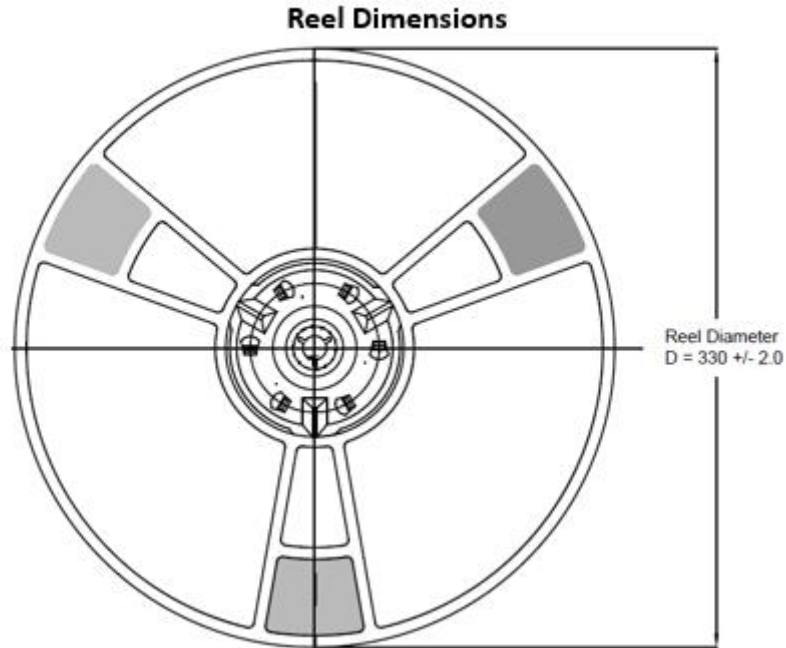

All pictures are only for reference, appearance depends on products

Table 52.Strip Package Parameters Specification

Device	Package	Pins	SPQ	Reel Diameter	A0	B0	K0	P1	W	Pin1
	Type			(mm)	(mm)	(mm)	(mm)	(mm)	(mm)	Quadrant
APM32F103RBT6	LQFP	64	1000	330	12.35	12.35	2.2	16	24	Q1
APM32F102RBT6	LQFP	64	1000	330	12.35	12.35	2.2	16	24	Q1
APM32F101RBT6	LQFP	64	1000	330	12.35	12.35	2.2	16	24	Q1
APM32F103CBT6	LQFP	48	2000	330	9.3	9.3	2.2	12	16	Q1
APM32F102CBT6	LQFP	48	2000	330	9.3	9.3	2.2	12	16	Q1
APM32F101CBT6	LQFP	48	2000	330	9.3	9.3	2.2	12	16	Q1
APM32F103TBU6	QFN	36	2500	330	6.4	6.4	1.4	8	16	Q1
APM32F101TBU6	QFN	36	2500	330	6.4	6.4	1.4	8	16	Q1

Figure 35. Tray Package Diagram

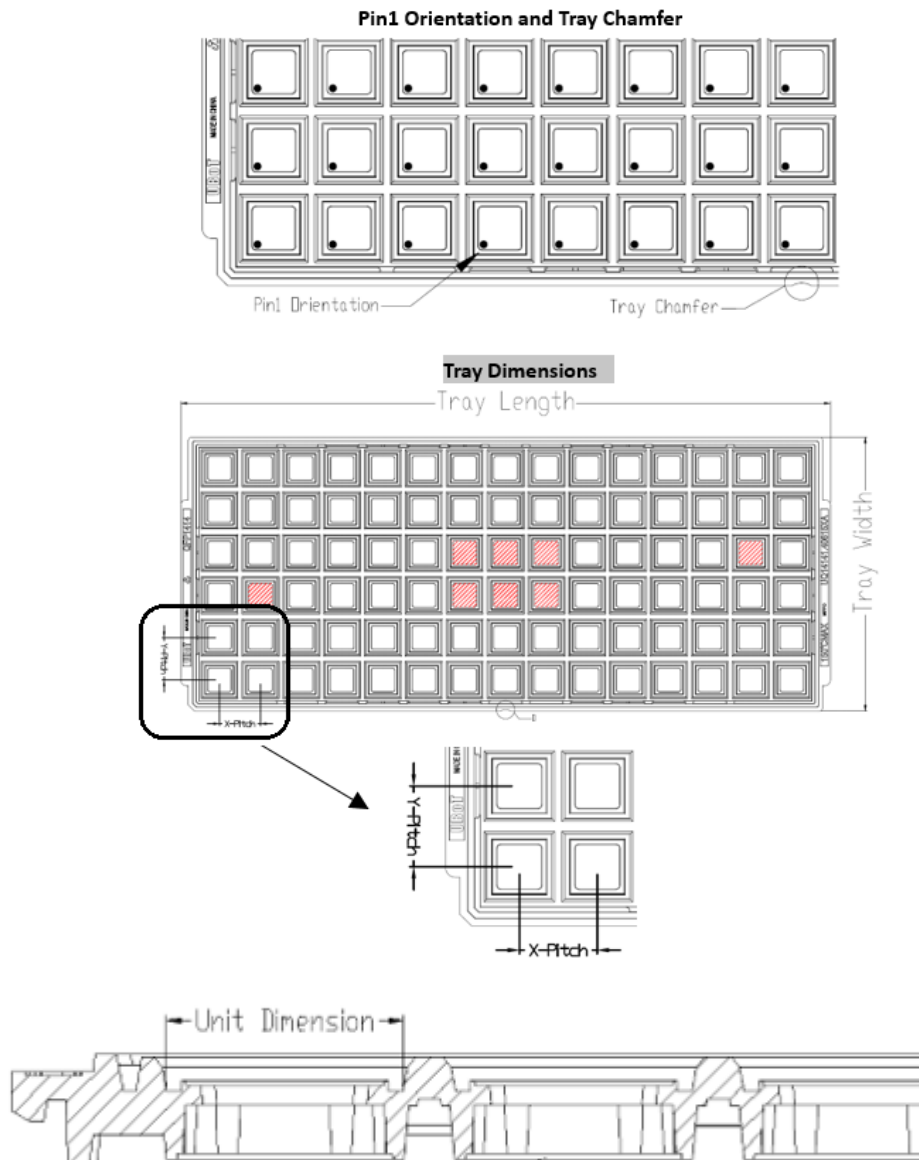

All the pictures are only for reference, appearance depends on products

Table 53. Tray Package Parameters Specification

Device	Package Type	Pins	SPQ	X-Dimension	Y-Dimension	X-Pitch	Y-Pitch	Tray Length	Tray Width
				(mm)	(mm)	(mm)	(mm)		
APM32F103VBT6	LQFP	100	900	16.6	16.6	20.3	21	322.6	135.9
APM32F101VBT6	LQFP	100	900	16.6	16.6	20.3	21	322.6	135.9
APM32F103RBT6	LQFP	64	1600	12.3	12.3	15.2	15.7	322.6	135.9
APM32F102RBT6	LQFP	64	1600	12.3	12.3	15.2	15.7	322.6	135.9
APM32F101RBT6	LQFP	64	1600	12.3	12.3	15.2	15.7	322.6	135.9
APM32F103CBT6	LQFP	48	2500	9.7	9.7	12.2	12.6	322.6	135.9

Device	Package Type	Pins	SPQ	X-Dimension	Y-Dimension	X-Pitch	Y-Pitch	Tray Length	Tray Width
				(mm)	(mm)	(mm)	(mm)	(mm)	(mm)
APM32F102CBT6	LQFP	48	2500	9.7	9.7	12.2	12.6	322.6	135.9
APM32F101CBT6	LQFP	48	2500	9.7	9.7	12.2	12.6	322.6	135.9
APM32F103TBU6	QFN	36	4900	6.2	6.2	8.8	9.2	322.6	135.9
APM32F101TBU6	QFN	36	4900	6.2	6.2	8.8	9.2	322.6	135.9

9. Commonly Used Function Module Denomination

Table 54. Commonly Used Function Module Denomination

Module Function	short title
Reset management unit	RMU
Clock management unit	CMU
Reset and Clock management unit	RCM
External Interrupt	EINT
General Purpose IO	GPIO
Alternate Function IO	AFIO
Wakeup controller	WUPT
Buzzer	BUZZER
Independent watchdog timer	IWDT
Window watchdog timer	WWDT
Timer	TMR
CRC Controller	CRC
Power management unit	PMU
The banked register	BAKPR
DMA Controller	DMA
analog-digital converter	ADC
digital-analog converter	DAC
Real-time clock	RTC
External storage controller	EMMC
SDIO Interface	SDIO
USB Device Controller	USB
Controller Local Area Network	CAN
USB OTG	OTG
Ethernet	ETH
I2C Interface	I2C
Serial Peripheral Interface	SPI
Universal Asynchronous Receiver / Transmitter	UART
Universal Asynchronous/Synchronous Receiver / Transmitter	USART
Flash memory interface control unit	FMC

10. Version History

Table 55. Document Version History

Date	Version	Change History
2/14/2019	1.0.0	Initial release
2/26/2019	1.0.1	Add the notes in Table 8
5/6/2019	1.0.2	Voltage was changed from 1.8V to 1.6V
1/3/2020	1.0.3	Added electrical characteristics and commonly used function module denomination, and modified the cover
1/24/2020	1.0.4	Extracted section 5.3 from section 5.2
3/4/2020	1.0.5	Generated section 3.14.2
6/22/2020	1.1.0	Adjust product characteristics, system block diagram, clock tree, storage map, power supply scheme
7/6/2020	1.1.1	Modified the directory format
9/9/2020	1.2	(1) to modify the chapter 7 "order information naming specification", "order information list" in the table to add "minimum packing number", "ordering code" (2) modifying the document font format
12/22/2020	1.2	(1) Change Note 7 in the Pin Description Table to Note 6 (2) Add Pin Description Note 6 Description (3) Updated the system block diagram
2/22/2021	1.2	(1) Modify HXT-HSECLK LXT-LSECLK HIRC-HSICLK LIRC-LSICLK USB-USBD (2) Modify the wrong name of PA14 pin in the pin definition (3) Change STO:STA in Figure 15 to STA:STO
8/9/2021	1.3	(1) Will be in the clock tree "4-16 MHz LSICLK OSC" correction for "4-16 MHz HSECLK" (2) Delete all details and names which are about APM32F103x4x6x8
6/30/2022	1.4	(1) Modify the Arm trademark (2) Add the statement (3) Add HSECLK oscillator transconductance g_m parameter
11/3/2022	1.5	(1) Modify pin definition PD10 default multiplexing function QSPI_ CMU is QSPI_ CLK (2) Modify ADC Features Table

Date	Version	Change History
		(3)Modify Table “Functions and peripherals of APM32F103xB”

Statement

This document is formulated and published by Geehy Semiconductor Co., Ltd. (hereinafter referred to as "Geehy"). The contents in this document are protected by laws and regulations of trademark, copyright and software copyright. Geehy reserves the right to make corrections and modifications to this document at any time. Please read this document carefully before using Geehy products. Once you use the Geehy product, it means that you (hereinafter referred to as the "users") have known and accepted all the contents of this document. Users shall use the Geehy product in accordance with relevant laws and regulations and the requirements of this document.

1. Ownership

This document can only be used in connection with the corresponding chip products or software products provided by Geehy. Without the prior permission of Geehy, no unit or individual may copy, transcribe, modify, edit or disseminate all or part of the contents of this document for any reason or in any form.

The “极海” or “Geehy” words or graphics with “®” or “™” in this document are trademarks of Geehy. Other product or service names displayed on Geehy products are the property of their respective owners.

2. No Intellectual Property License

Geehy owns all rights, ownership and intellectual property rights involved in this document.

Geehy shall not be deemed to grant the license or right of any intellectual property to users explicitly or implicitly due to the sale or distribution of Geehy products or this document.

If any third party's products, services or intellectual property are involved in this document, it shall not be deemed that Geehy authorizes users to use the aforesaid third party's products, services or intellectual property, unless otherwise agreed in sales order or sales contract.

3. Version Update

Users can obtain the latest document of the corresponding models when ordering Geehy products.

If the contents in this document are inconsistent with Geehy products, the agreement in the sales order or the sales contract shall prevail.

4. Information Reliability

The relevant data in this document are obtained from batch test by Geehy Laboratory or cooperative third-party testing organization. However, clerical errors in correction or errors caused by differences in testing environment may occur inevitably. Therefore, users should understand that Geehy does not bear any responsibility for such errors that may occur in this document. The relevant data in this document are only used to guide users as performance parameter reference and do not constitute Geehy's guarantee for any product performance.

Users shall select appropriate Geehy products according to their own needs, and effectively verify and test the applicability of Geehy products to confirm that Geehy products meet their own needs, corresponding standards, safety or other reliability requirements. If losses are caused to users due to the user's failure to fully verify and test Geehy products, Geehy will not bear any responsibility.

5. Legality

USERS SHALL ABIDE BY ALL APPLICABLE LOCAL LAWS AND REGULATIONS WHEN USING THIS DOCUMENT AND THE MATCHING GEEHY PRODUCTS. USERS SHALL UNDERSTAND THAT THE PRODUCTS MAY BE RESTRICTED BY THE EXPORT, RE-EXPORT OR OTHER LAWS OF THE COUNTRIES OF THE PRODUCTS SUPPLIERS, GEEHY, GEEHY DISTRIBUTORS AND USERS. USERS (ON BEHALF OR ITSELF, SUBSIDIARIES AND AFFILIATED ENTERPRISES) SHALL AGREE AND PROMISE TO ABIDE BY ALL APPLICABLE LAWS AND REGULATIONS ON THE EXPORT AND RE-EXPORT OF GEEHY PRODUCTS AND/OR TECHNOLOGIES AND DIRECT PRODUCTS.

6. Disclaimer of Warranty

THIS DOCUMENT IS PROVIDED BY GEEHY "AS IS" AND THERE IS NO WARRANTY OF ANY KIND, EITHER EXPRESSED OR IMPLIED, INCLUDING, BUT NOT LIMITED TO, THE WARRANTIES OF MERCHANTABILITY AND FITNESS FOR A PARTICULAR PURPOSE, TO THE EXTENT PERMITTED BY APPLICABLE LAW.

GEEHY WILL BEAR NO RESPONSIBILITY FOR ANY DISPUTES ARISING FROM THE SUBSEQUENT DESIGN OR USE BY USERS.

7. Limitation of Liability

IN NO EVENT UNLESS REQUIRED BY APPLICABLE LAW OR AGREED TO IN WRITING WILL GEEHY OR ANY OTHER PARTY WHO PROVIDE THE DOCUMENT "AS IS", BE LIABLE FOR

DAMAGES, INCLUDING ANY GENERAL, SPECIAL, DIRECT, INCIDENTAL OR CONSEQUENTIAL DAMAGES ARISING OUT OF THE USE OR INABILITY TO USE THE DOCUMENT (INCLUDING BUT NOT LIMITED TO LOSS OF DATA OR DATA BEING RENDERED INACCURATE OR LOSSES SUSTAINED BY USERS OR THIRD PARTIES).

8. Scope of Application

The information in this document replaces the information provided in all previous versions of the document.

© 2019-2022 Geehy Semiconductor Co., Ltd. - All Rights Reserved