

UNIT: mm (毫米)

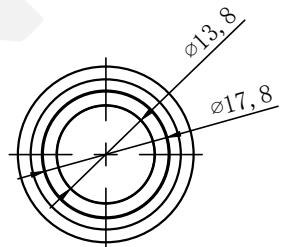

开关结构说明:  
Switch structure description:

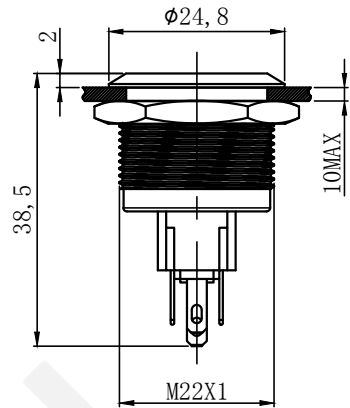
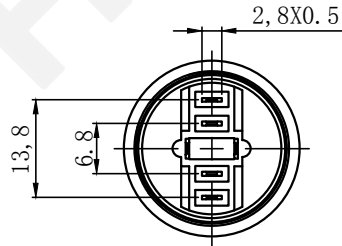
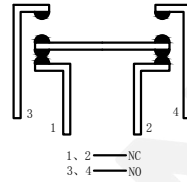

灯珠等效电路:  
Lamp bead equivalent circuit:



安装孔尺寸:  
Mounting hole size:

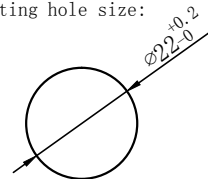

**Technical requirements:**

1. The surface is smooth without burr
2. Rated voltage: 1th: 5A Ui: 250V
3. Working environment temperature: -25 ~ +65
4. Operation type: Momentary
5. Movement stroke: About 2.5 mm
6. Connection form: Matching connectors/Welding wire
7. Tightening torque: About 0.6 nm
8. Contact configuration: 1N01NC
9. Appearance material:  
Button surface: PC/Stainless steel  
Housing: Stainless steel  
Base: PBT  
Contact: Silver alloy
10. Lamp bead parameters:  
Rated voltage: 6V/12V/24V/36V; 110V/220V  
Rated current: 20 mA
11. LED Color: Red/Green/Yellow/Orange/Blue/White
12. LED Life: 50,000 hours

**HBAN**  
**红波**

**Performance requirements:**

1. Protection grade: IP65
2. Contact resistance: 50 m
3. Insulation resistance: 100 m
4. Dielectric Intensity: AC2500V, 1 min, No flicker or breakdown
5. Life:  
Electrical part: No abnormal movement for 50,000 times, under rated load  
Mechanical part: No abnormal movement for 1000,000 times

描 图
描 校
底 图 号
装 订 号

					SHANGHAI HONGBO ELECTRIC CO. LTD.
					上海红波电器有限公司
标记	处数	更改文件号	签字	日期	名称(TITLE): M22 Metal waterproof button switch
DR. 制图	APPD. 审核	SCALE. 比例	countersign. 会签	Date. 日期	M22金属防水按钮开关
倪力晓	陈秋霞	1:1		2019.12.5	图号(DWG NO): HBGQ22F-11E/J/S
PW. 单重		P. 页码	第1页 共1页(1/1)		