



Electrochemical Alcohol Sensor

AL-03S (Standard type)



Features

- Linearity
- Excellent Selectivity
- Perfect leak-proof structure
- Easy handling and direct soldering
- Small size
- Excellent cost-effective performance

Specifications

Sensitivity Characteristics

Detection Gas	Alcohol (Ethanol)
Detection Range	0 ~ 2.0mg/L
Output Current	10 ~ 30 μ A
Repeatability	< \pm 5%
Response Time	< 3.0seconds
Expected Life Time	3years <

Performance data conditions: 20°C, 50%RH and 1013mBar, under MGK SENSOR recommended conditions.

Operating Conditions

Operating Temperature	10 ~ 40°C
Operating Humidity	10 ~ 90% RH
Recommended Absorption Volume	0.3cc
Recommended Absorption Time	0.4seconds
Position Sensitivity	None

Storage Conditions

Temperature	-20 ~ 50°C
Recommended Storage Temperature	0 ~ 20°C
Storage period	6months in container

Physical Characteristics

Cap Color	Gray
Electric Pin	ϕ 0.45, Brass Au-plated
Weight	1.2 g (approx.)

Appearance and Dimensions

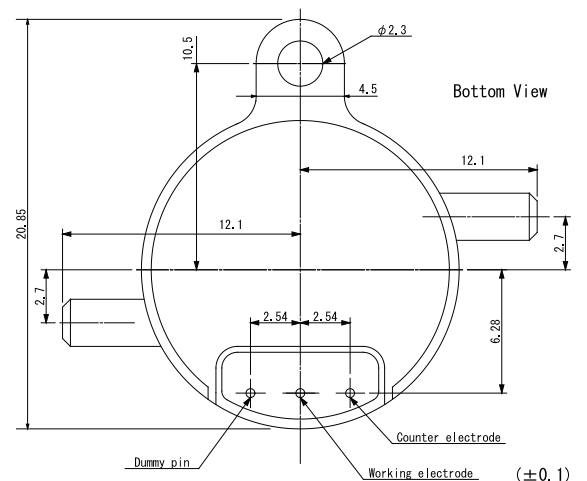
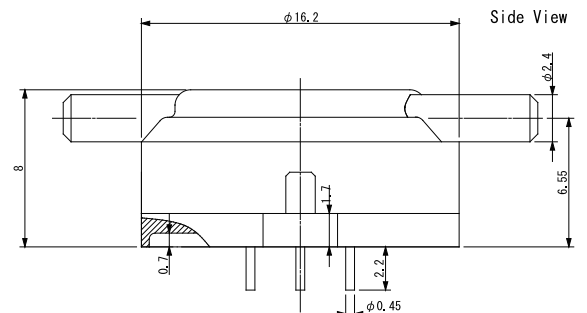

Typical Selectivity

Test Gas	Gas Concentration (mg/L)	Typical Ethanol Concentration Equivalent (mg/L)
Ethanol	0.150	0.150
Carbon Monoxide	0.10	0.008
Acetone	0.25	0
Methanol	0.05	0.045
2-Propanol	0.05	0.023
Toluene	0.10	0

Temperature dependency

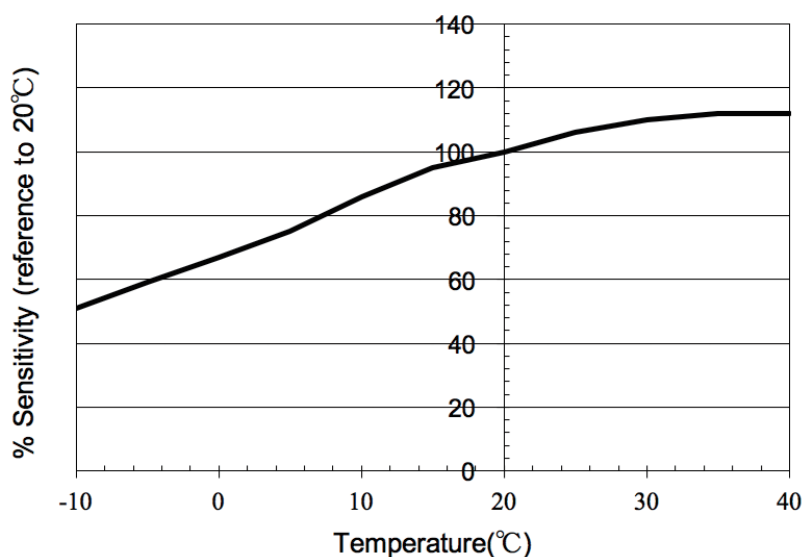

Typical Output signal

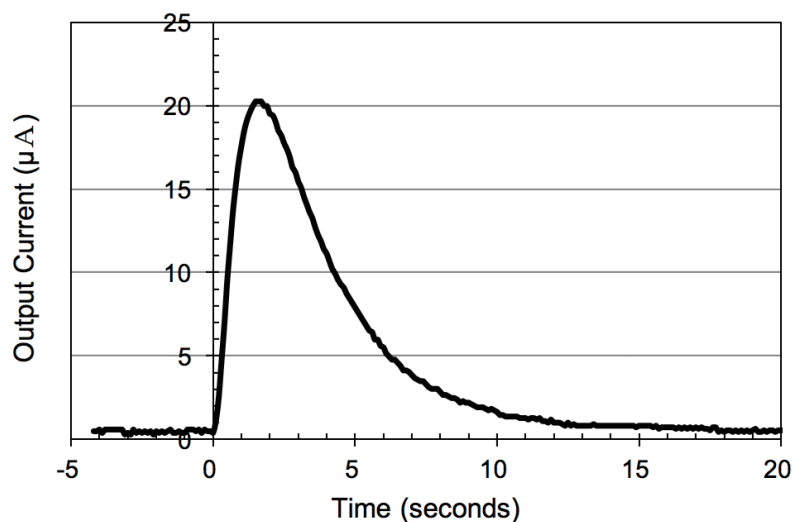

Conditions: Ethanol concentration 0.150 mg/L, Load resistor 10 Ω

NOTE: AL-03S DN-1021 Nov. 2017

As the products may be use outside control of MGK SENSOR, the information provided is given without legal responsibility. Customer should test under their own conditions, to ensure that the sensors are suitable for their own requirements.
In accordance with the company' s policy of continued product improvement, MGK SENSOR reserves the right to make product changes without notice.

