

UNIT: mm (毫米)

HBAN 红波

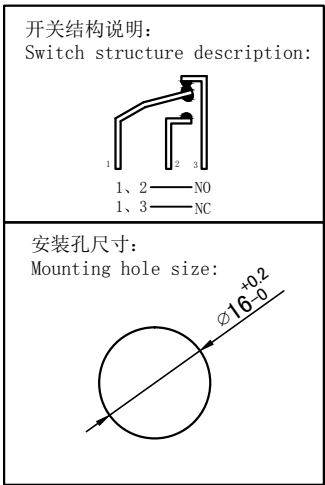
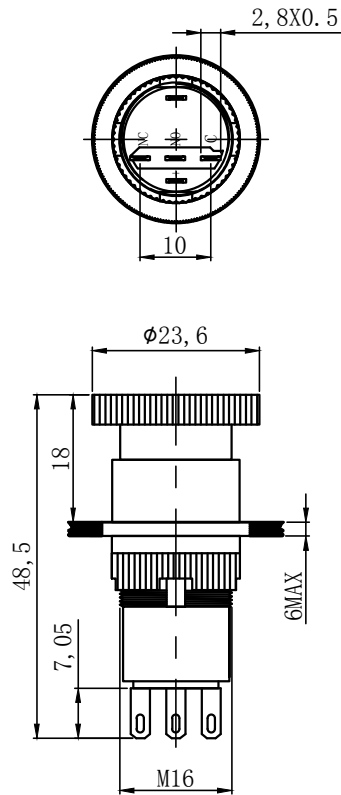

- 性能要求:
Performance requirements:
- 防护等级: IP40;
Protection grade: IP40;
 - 接触电阻: $\leq 50m\Omega$;
Contact resistance: $\leq 50m\Omega$
 - 绝缘电阻: $\geq 100M\Omega$;
The insulation resistance: $\geq 100M\Omega$.
 - 抗电强度: AC2500V, 1min, 无闪烁、击穿;
Electrical resistance: AC2500V, 1min, no flicker and breakdown;
 - 寿命: 电气部分在额定负载下动作50万次无异常。
Life: electrical part: operate 50,000 times under rated load without any abnormality.
机械部分: 动作50万次无异常;
Mechanical part: no abnormal movement for 500,000 times

- 技术要求:
Technical requirements:
- 表面光洁, 平整无毛刺;
The surface is smooth and smooth without burr;
 - 参数/批次字迹清晰, 无错位;
Clear handwriting of parameters/batches without any dislocation;
 - 额定电压: Ith: 5A Ui: 250V;
Rated voltage: 5A Ui: 250V;
 - 工作环境温度: $-25^{\circ}C \sim +65^{\circ}C$;
Working environment temperature: $-25^{\circ}C \sim +65^{\circ}C$;
 - 动作形式: 自锁式;
Action form: self-locking ;
 - 动作行程: 约3.5mm;
Movement stroke: about 3.5mm
 - 连接形式: 配套接插件/焊接导线;
Connection form: supporting connector/welding wire;
 - 拧紧力矩: 5~14Nm;
Tightening torque: 5~14nm;
 - 开关组合: 1NO1NC;
Switch combination: 1NO1NC;
 - 外观材料: 按键: PC;
外壳: ABS;
螺母: PC
触点: 银合金;
Appearance material: Case: PC;
Keypad: ABS;
Nut: PC
Contact: silver alloy
 - 未标注公差按照GB/T 1804-m级。
Unmarked tolerance shall be in accordance with GB/T 1804-f class.

描 图
描 校
底 图 号
装 订 号

					SHANGHAI HONGBO ELECTRIC CO. LTD.
					名称(TITLE): M16 plastic emergency stop switch
标 记	处 数	更改文件号	签 字	日 期	
DR 制 图	APPD. 审 核	SCALE. 比 例	countersign 会 签	Date. 日 期	
倪力晓	陈秋霞	1:1		2019.12.6	图号(DWG NO): SW-EM16FA-10A-J-HB
PW 单 重		P. 页 码	第1页 共1页(1/1)		