

# 270x270x99 mm

San Ace 221W 9B1W2TP type

## General Specifications

- Material ..... Motor case: Aluminum (Black coating), Impeller: Plastic (Flammability: UL 94V-0)  
Bracket: Aluminum (Black coating), Plastic (Flammability: UL94V-0)
- Expected life ..... See the table below. (L10 life: 90% survival rate for continuous operation in indoor free air at 60°C, rated voltage)  
Expected life at 40°C is for reference only.
- Motor protection function ..... Locked rotor burnout protection, Reverse polarity protection  
For details, please refer to p. 599.
- Dielectric strength ..... 50/60 Hz, 500 VAC, for 1 minute (between lead wire conductors and bracket)
- Insulation resistance ..... 10 MΩ or more with a 500 VDC megger (between lead wire conductors and bracket)
- Sound pressure level (SPL) ..... At 1 m away from the air inlet
- Storage temperature ..... -30 to +70°C (Non-condensing)
- Lead wire ..... ⊕Red ⊖Black  Sensor Yellow  Control Brown
- Mass ..... 1900 g
- Ingress protection ..... IP56

## Specifications

The models listed below **have pulse sensors with PWM control function.**

Model no.	Rated voltage [V]	Operating voltage range [V]	PWM duty cycle [%]	Rated current [A]	Rated input [W]	Rated speed [min <sup>-1</sup> ]	Max. airflow [m <sup>3</sup> /min] [CFM]	Max. static pressure [Pa] [inchH <sub>2</sub> O]	SPL [dB (A)]	Operating temperature [°C]	Expected life [h]
9B1W2TP24P0H001	24	16 to 36	100	3.35	80.4	3050	17.6 621	530 2.13	71.5	-25 to +70	40000/60°C (70000/40°C)
			15	0.4	9.6	1000	5.75 203	57.0 0.23	53.5		
9B1W2TP48P0S001	48	36 to 72	100	2.3	110.4	3400	19.6 692	659 2.65	73.5		
			15	0.2	9.6	1000	5.75 203	57.0 0.23	53.5		

\* PWM input frequency is 25 kHz; models without specifications at 0% PWM duty cycle have zero fan speed at 0%.

Note 1: The maximum rated input value of 9B1W2TP24P0H001: 150 W and 9B1W2TP48P0S001: 210 W.  
Note 2: Sensor and control options are available for selection. Refer to the table on p. 625.

## Airflow - Static Pressure Characteristics / PWM Duty - Speed Characteristics Example

**9B1W2TP24P0H001** With pulse sensor with PWM control function

PWM duty cycle

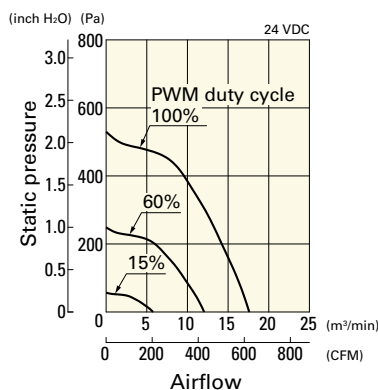

Operating voltage range

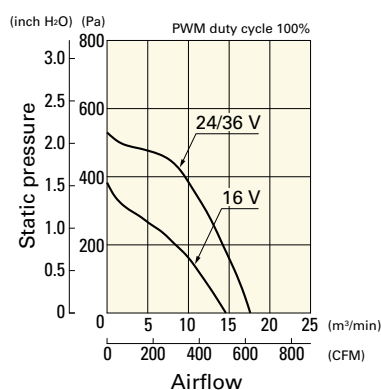

PWM duty - Speed characteristics example

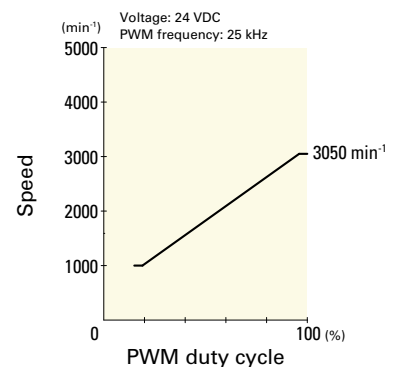

## Airflow - Static Pressure Characteristics / PWM Duty - Speed Characteristics Example

**9B1W2TP48P0S001** With pulse sensor with PWM control function

PWM duty cycle

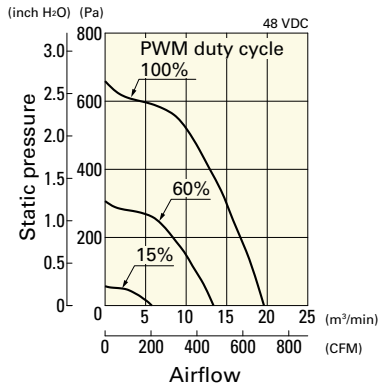

Operating voltage range

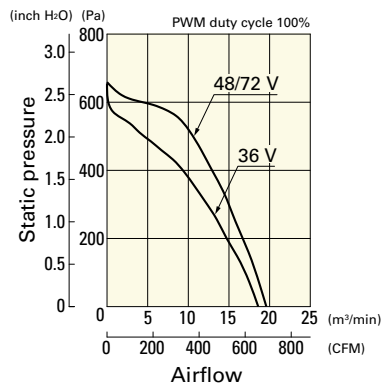

PWM duty - Speed characteristics example

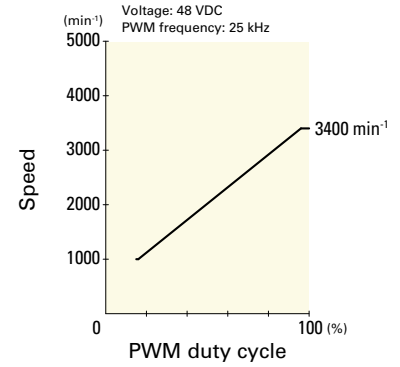

## Dimensions (unit: mm)

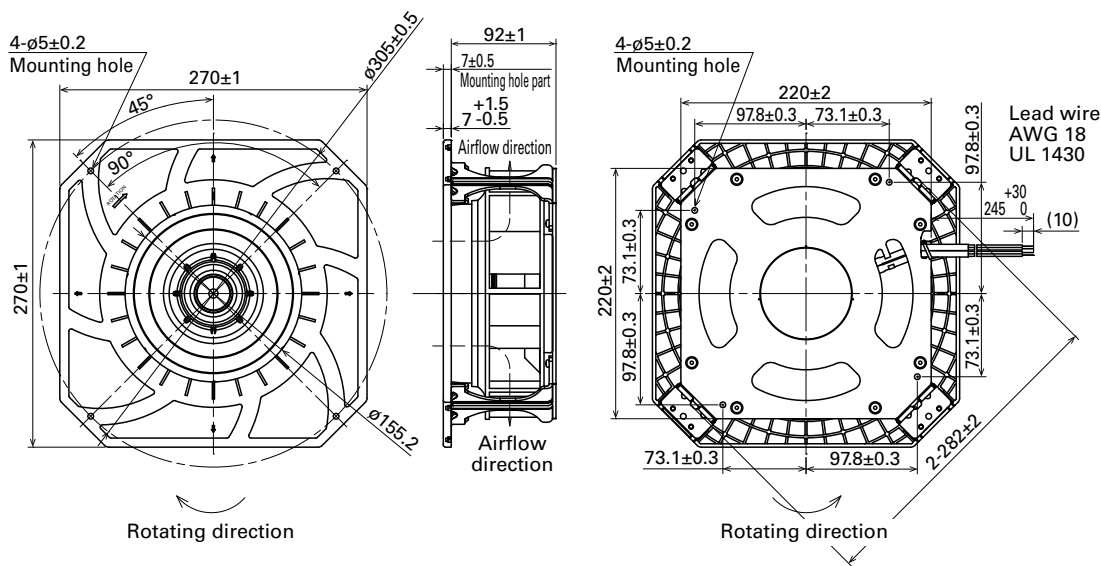

## Reference Dimensions of Mounting Holes and Vent Opening (unit: mm)

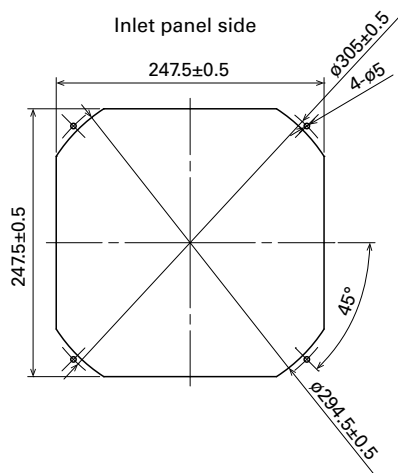

## Reference Diagram for Mounting

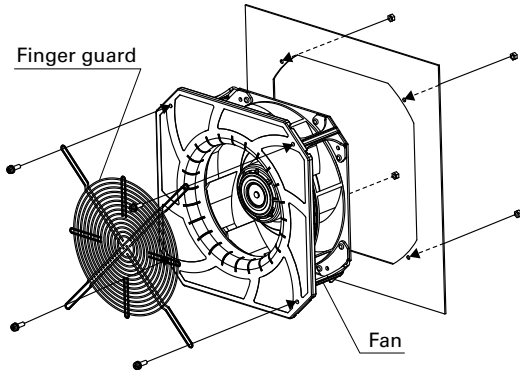

## Options

Finger guards

page: p. 588

Model no.: 109-1146, 109-1146H