

---

**SURFACE MOUNT LED TAPE AND REEL**



Lead-Free Parts

**PRELIMINARY**

This is just a preliminary design  
to let you evaluate the concept

AM-LG-P3528UYR-T50

**DATA SHEET**

DOC. NO : IMQW0905-AM-LG-P3528UYR-T50

REV. : B

DATE : 05 - Sep. - 2019

## Features:

1. White SMD with PLCC 4 package.
2. Top view LED Package & Dimensions : 3.5x2.8x1.8 (unit:mm)
3. Luminous color:yellow(Wd:590nm)
4. Viewing angle:120°
5. Compliant with RoHS and REACH

## Application:

1. Automotive parts
2. Backlight
3. Interior and Exterior Illumination
4. General applications

## Device Selection Guide:

PART NO	MATERIAL	COLOR	
		Emitted	Lens
AM-LG-P3528UYR-T50	AlGaInP	Yellow	Water Clear

## Package Dimensions

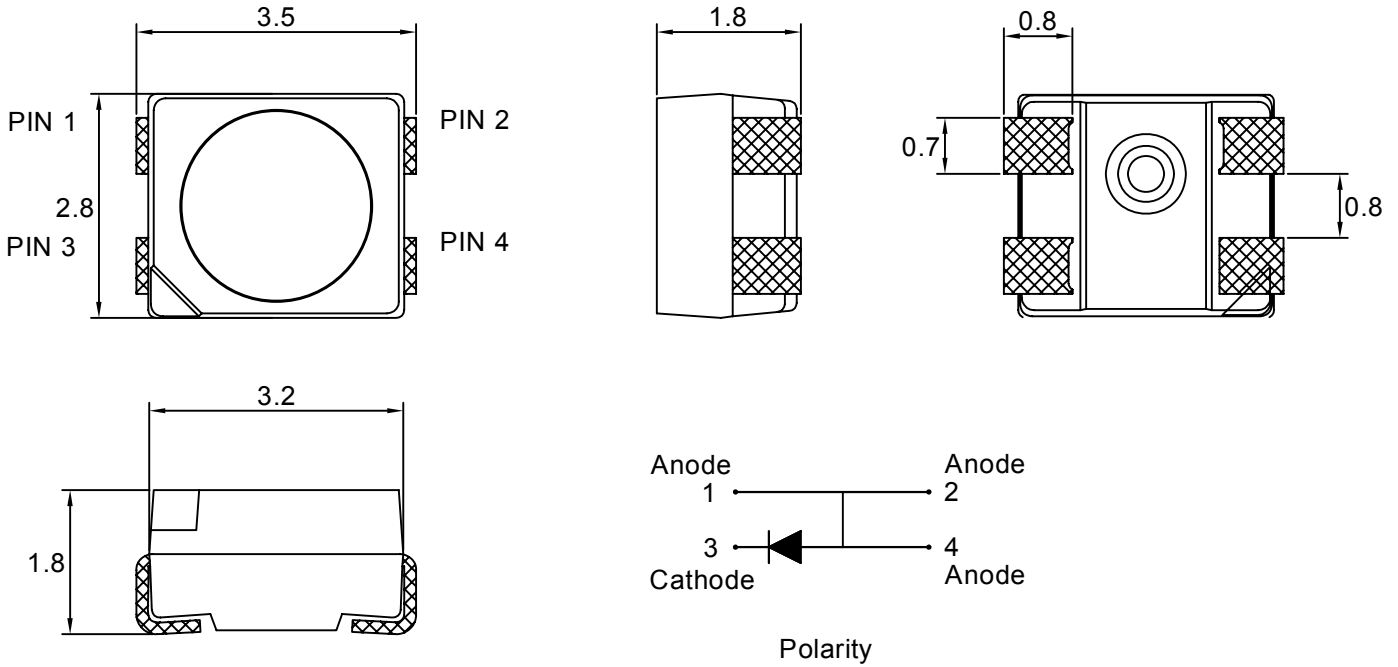

Note : 1.All dimension are in millimeter tolerance is  $\pm 0.2\text{mm}$  unless otherwise noted.  
2.Specifications are subject to change without notice.

## Recommended Soldering Pad Dimensions

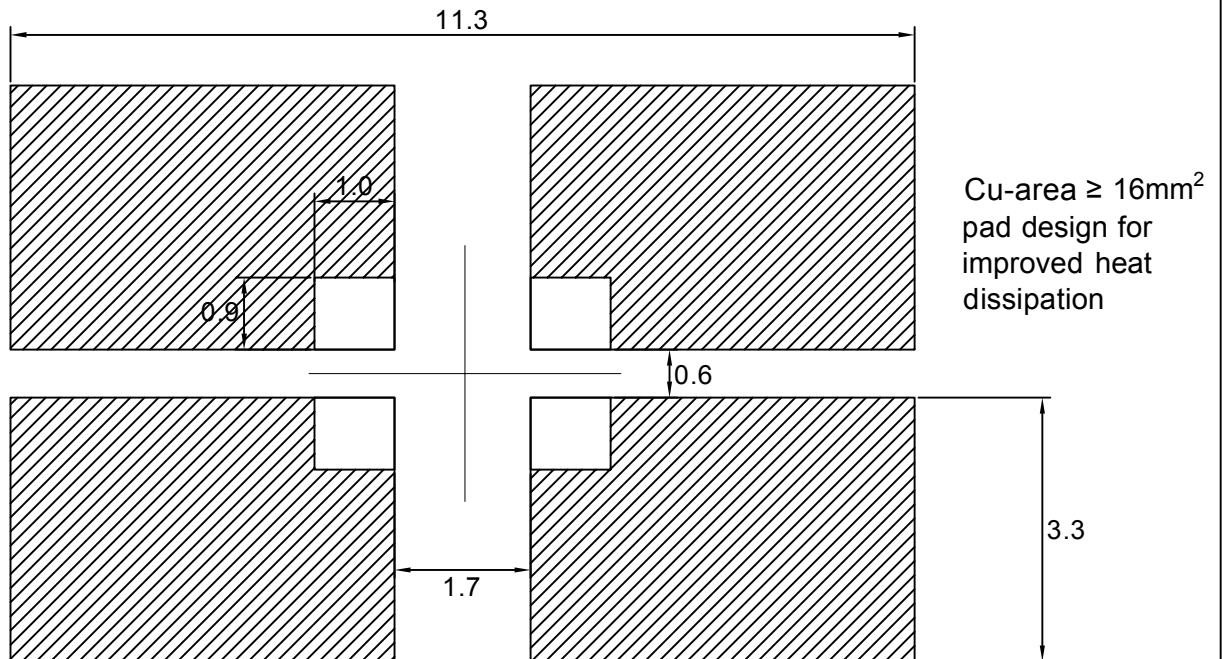

Note : The tolerances unless mentioned is  $\pm 0.1\text{mm}$ . Unit=mm.

### Absolute Maximum Ratings at Ta=25°C

Parameter	Symbol	Ratings	UNIT
Forward Current	IF	70	mA
Peak Forward Current Duty 1/10@10KHz	IFP	140	mA
Power Dissipation	PD	196	mW
Reverse Current @12V	Ir	5	μA
Electrostatic Discharge	ESD	2000	V
Operating Temperature	Topr	- 40 ~ + 100	°C
Storage Temperature	Tstg	- 40 ~ + 100	°C
LED junction Temperature	Tj	125	°C
Thermal resistance*	Rth j-s	100	K/W

### Typical Electrical & Optical Characteristics (Ta=25°C)

Items	Symbol	Min.	Typ.	Max.	UNIT	CONDITION
Luminous Intensity	Iv	1120	2250	3550	mcd	IF=50mA
Dominant Wavelength	λD	583	590	595	nm	IF=50mA
Spectral Line Half-Width	Δλ	----	15	----	nm	IF=50mA
Forward Voltage	V <sub>F</sub>	1.9	----	2.8	V	IF=50mA
Viewing Angle	2θ 1/2	----	120	----	deg	IF=50mA

Note : 1.The forward voltage data did not including ±0.1V testing tolerance.  
2.The luminous intensity data did not including ±15% testing tolerance.  
3.The dominant wavelength data did not including ±1nm testing tolerance

### Luminous Intensity Classification

BIN CODE	Iv(mcd) at50mA	
	Min.	Max.
AA	1120	1400
AB	1400	1800
BA	1800	2240
BB	2240	2800
CA	2800	3550

### Dominant Wavelength Classification

BIN CODE	$\lambda D$ (nm) at50mA	
	Min.	Max.
Y1	583	586
Y2	586	589
Y3	589	592
Y4	592	595

### Forward Voltage Classification

BIN CODE	Vf(v) at 50mA	
	Min.	Max.
2	1.90	2.05
3	2.05	2.20
4	2.20	2.35
5	2.35	2.50
6	2.50	2.65
7	2.65	2.80

## Typical Electro-Optical Characteristics Curve

Fig.1 Forward current vs. Forward Voltage

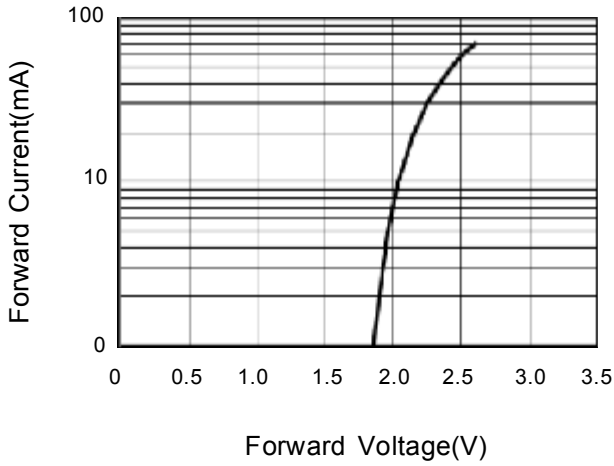

Fig.2 Luminous Intensity vs. Forward Current

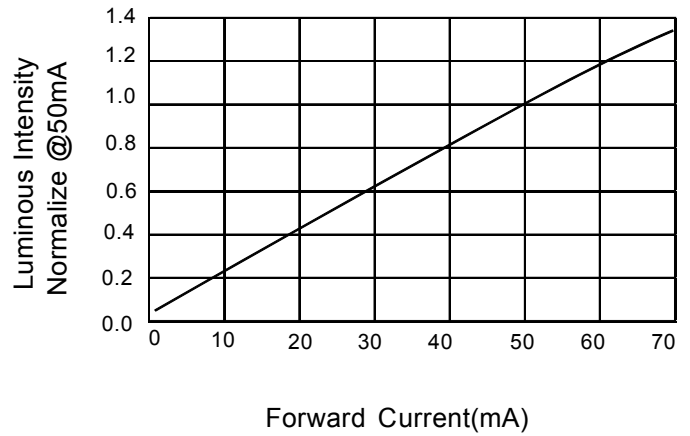

Fig.3 Forward Current vs. Temperature

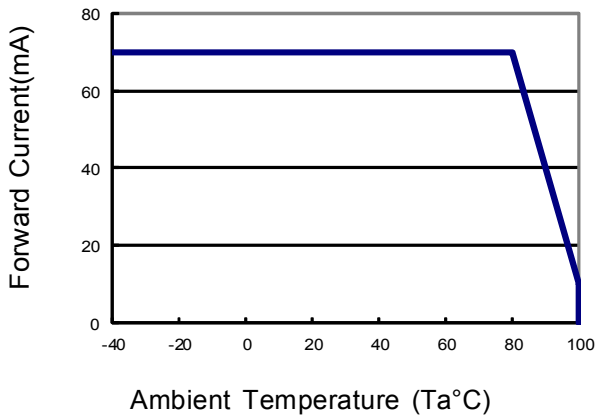

Fig.4 Luminous Intensity vs. Temperature

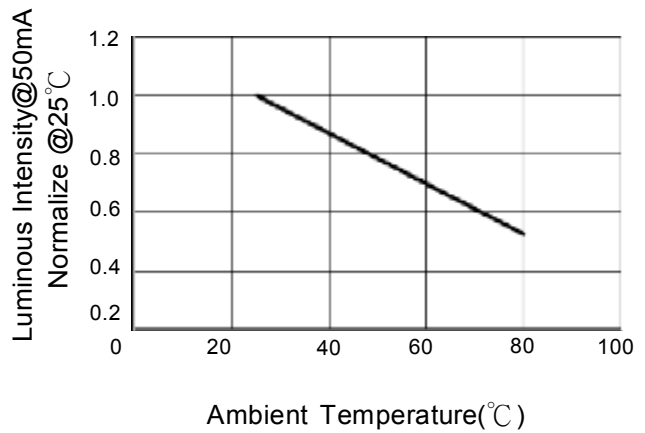

Fig.5 Relative Intensity vs. Wavelength

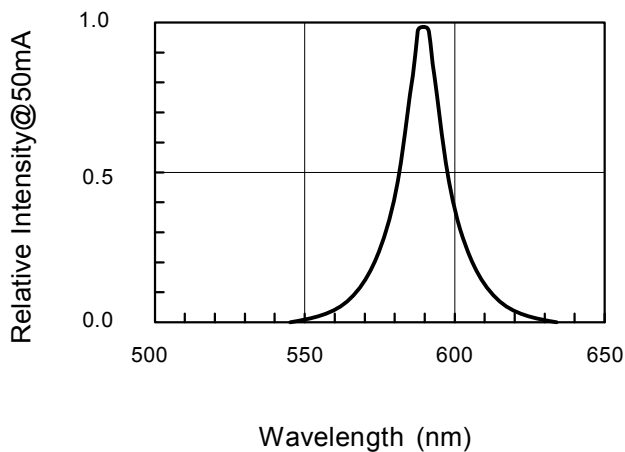
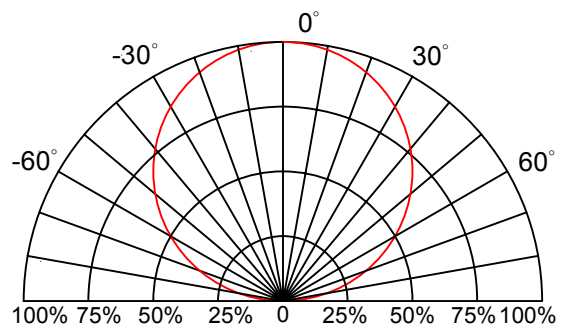
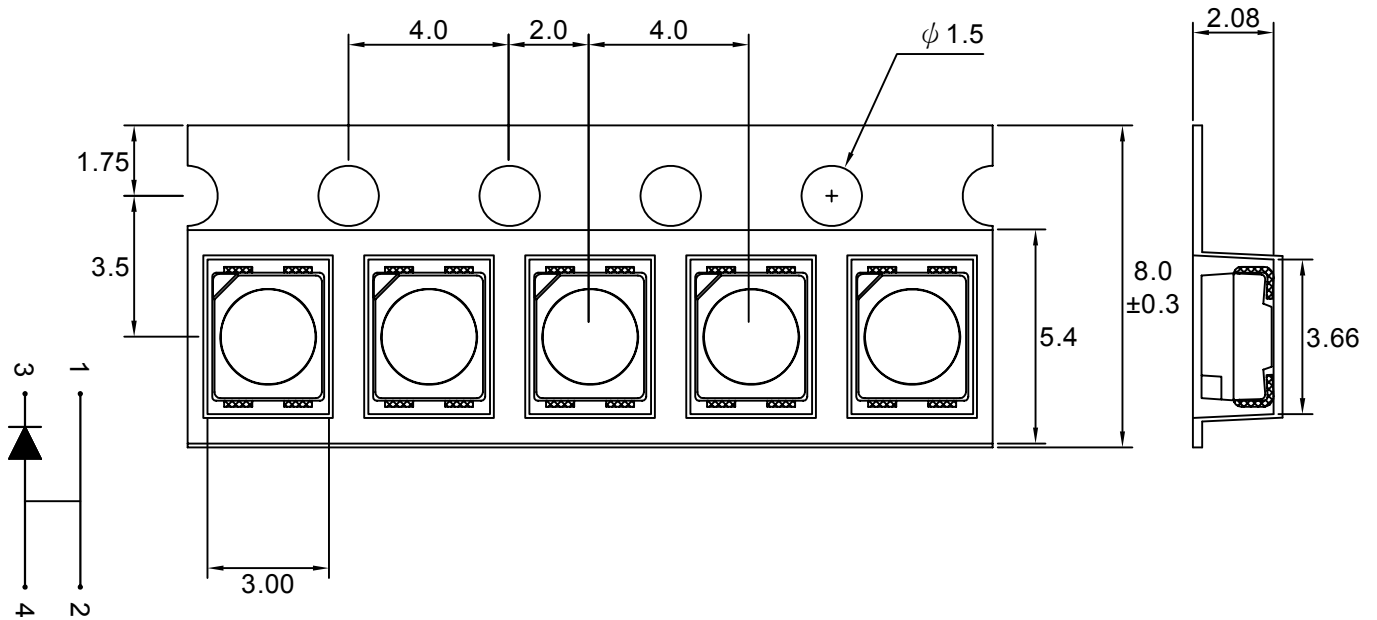

Fig.6 Directive Radiation



## Carrier Type Dimensions







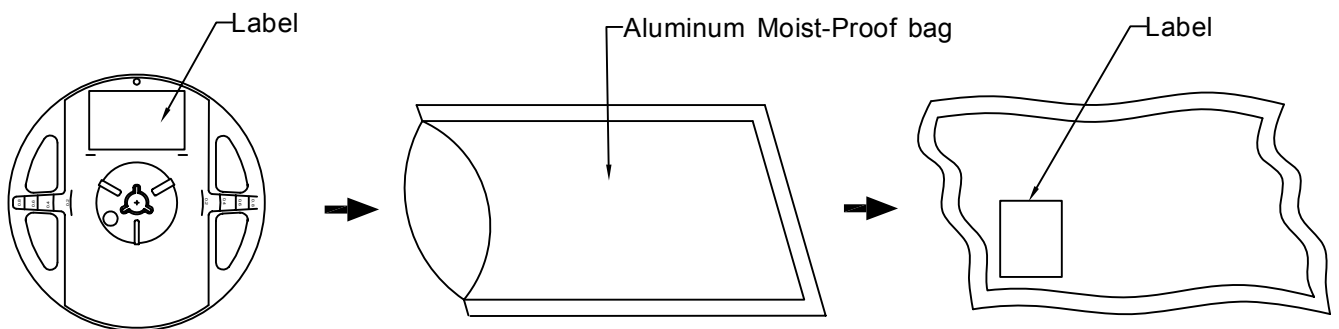

Note : The tolerances unless mentioned is  $\pm 0.1$ mm,Unit=mm.

## Packing Specifications



Part No.	Description	Quantity/Reel
AM-LG-P3528UYR-T50	8.0mm tape,7"reel	2000 PCS

## Label Explanation

	LIGITEK ELECTRONICS CO., LTD.	
		
	PART :	AM-LG-P3528UYR-T50
		
	LOT :	GS11680168
		
QTY(PCS):	2000	
		
BIN/HUE :	AA/Y2	 VF:2.05-2.2

BIN : Luminous Intensity

HUE : Dominant Wavelength

VF : Forward Voltage

## Reel Dimensions

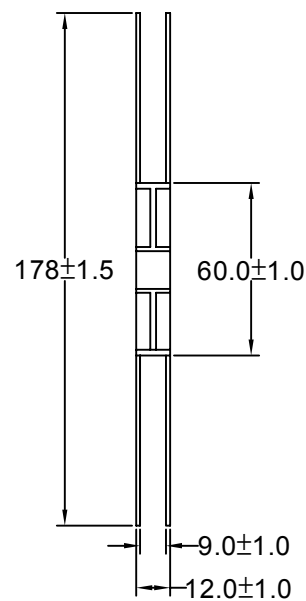
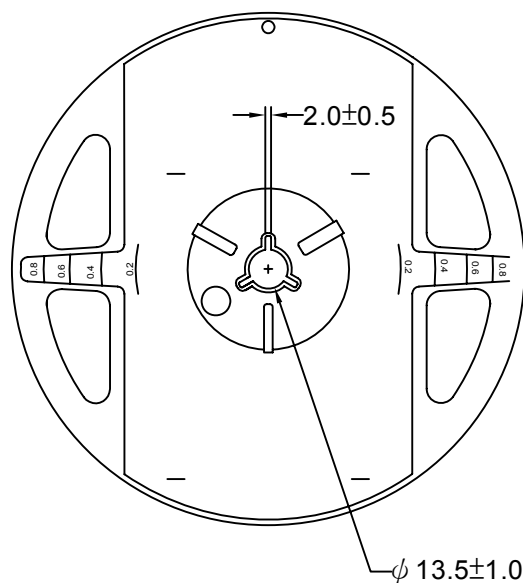



PART NO. AM-LG-P3528UYR-T50

Page 8/11

## Box Explanation

1. 5 BAG / INNER BOX
2. INNER BOX SIZE : L X W X H 23cm X 8.5cm x 26cm

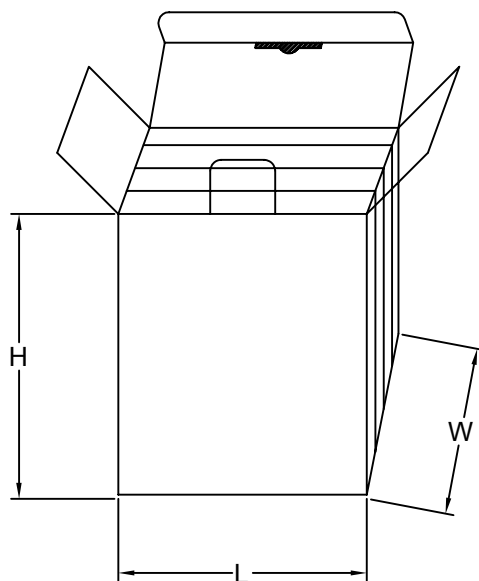

3. 10 INNER BOXES / CARTON
4. CARTON SIZE : L X W X H 58cm X 34cm x 35cm

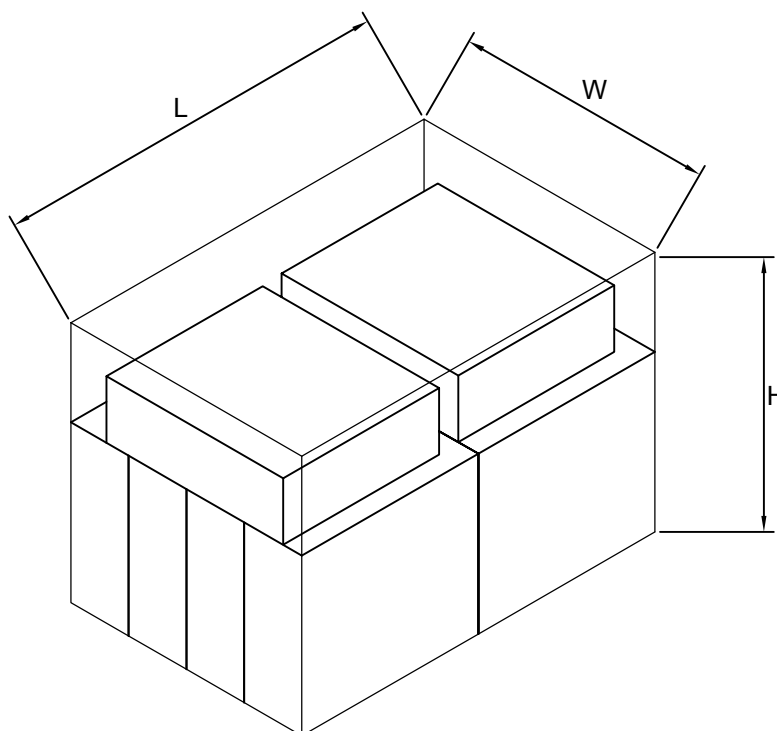

**Recommended Soldering Conditions****1. Hand Solder**

Basic spec is  $\leq 320^{\circ}\text{C}$  3 sec one time only.

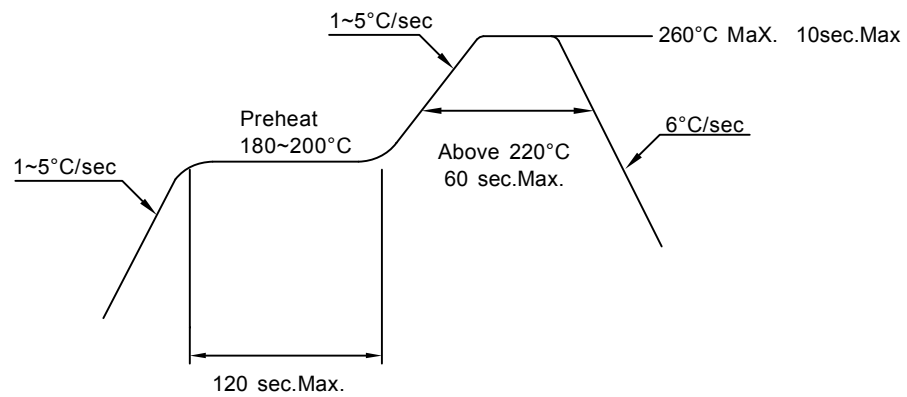
**2. PB-Free Reflow Solder****Note:**

- 1.Reflow soldering should not be done more than two times.
- 2.When soldering,do not put stress on the LEDs during heating.
- 3.After soldering,do not warp the circuit board.

**Precautions For Use:****Storage time:**

1. Calculated shelf life before opening is 12 months at  $< 30^{\circ}\text{C}$  and  $< 90\%$  relative humidity (RH)
2. After bag is opened, devices which will be subjected to reflow soldering or other high temperature processes must be
  - a) Assembled within 168 hours in an environment of  $\leq 30^{\circ}\text{C}$  / 60% RH, or
  - b) Stored at ambient of 10% RH or less
3. Devices are required baking before assembly if:
  - a) Humidity Indicator Card reads  $>10\%$  (for level 2a -5a) or  $>60\%$  (for level 2) at ambient temperature  $23\pm 5^{\circ}\text{C}$
  - b) 2.a) or 2.b) doesn't meet
4. If baking is required, devices should be baked for  $>72$  hours at  $60\pm 5^{\circ}\text{C}$  / 5% RH. Performing baking only once, and using the baked devices within 72 hours.  
MSL LEVEL 3

**Drive Method:**

LED is a current operated device, and therefore, requires some kind of current limiting incorporated into the driver circuit. This current limiting typically takes the form of a current limiting resistor placed in series with the LED.

Consider worst case voltage variations than could occur across the current limiting resistor. The forward current should not be allowed to change by more than 40% of its desired value.

Circuit model A

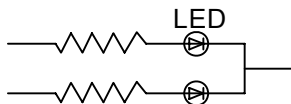

Circuit model B

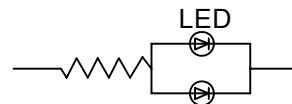

(A) Recommended circuit.

(B) The difference of brightness between LED could be found due to the VF-IF characteristics of LED.

**Cleaning:**

Use alcohol-based cleaning solvents such as isopropyl alcohol to clean the LED.

**ESD(Electrostatic Discharge):**

Static Electricity or power surge will damage the LED. Use of a conductive wrist band or anti-electrostatic glove is recommended when handling these LED. All devices, equipment and machinery must be properly grounded.