

CD-SA1209D GNSS standalone module

Data Sheet V.03

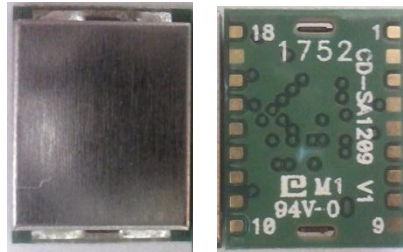

Table of Contents

1. Functional Description	3
1.1 Product description	3
1.2 Features	4
1.3 System Block Diagram	5
1.4 Multi-tone active interference canceller	5
1.5 1PPS	5
1.6 AGPS Support for Fast TTFF (EPO™)	5
1.7 AlwaysLocate™ (Advance Power Periodic Mode).....	6
1.8 EASY™	6
1.9 Embedded Logger function	6
2. Specifications.....	7
2.1 Mechanical Dimension	7
2.2 Recommended PCB pad Layout.....	7
2.3 Pin Configuration	8
2.4 Pin Assignment	8
2.5 Description of I/O Pin	9
2.6 Specification List	11
2.7 Absolute Maximum Ratings.....	12
2.8 Operating Conditions.....	12
2.9 GPS External Antenna Specification (Recommended)	12
3. Protocols	13
3.1 NMEA Output Sentences	13
3.2 MTK NMEA Command Protocols.....	20
4. Reference Design	21
4.1 Patch (Passive) Antenna	21
4.2 Active Antenna	22
5. Tape Reel Packing Information.....	23

1. Functional Description

1.1 Product description

The CDTOP CD-SA1209D module utilizes the MediaTek new generation GNSS Chipset MT3333 that support various location and navigation applications, including autonomous GPS, GLONASS, GALILEO (on request), QZSS, SBAS (note) ranging (WAAS, EGNOS, GAGAN, MSAS), QZSS, DGPS (RTCM) and AGPS. It support up to 210 PRN channels with 99 search channels and 33 simultaneous tracking channels.

It is the industry's highest level of sensitivity (-165dBm) and instant Time-to-First Fix (TTFF). Precise GNSS signal processing give the ultra-precise positioning under low receptive, high velocity conditions. Up to 12 multi-tone active interference canceller (ISSCC2011 award), customer can have more flexibility in system design.

Power management design makes CD-SA1209D easily integrated into your system without extra voltage regulator. CD-SA1209D allows direct battery connection, no need any external LDO and gives customers plenty of choices for their application circuit.

The excellent low power consumption of CD-SA1209D make it easier to applied to power sensitive devices, especially portable applications, need not worry about operating time anymore and user can get more fun.

It also combined with many advanced features including AlwaysLocate™, EASY™, EPO™, and logger function.

Application:

- ✓ Asset management
- ✓ Handheld Device
- ✓ M2M application
- ✓ Security industry
- ✓ Surveillance
- ✓ Tablet PC/PLB/MID

1.2 Features

- 33 tracking/ 99 acquisition-channel GPS/GLONASS/GALILEO receiver
- AGPS Support for Fast TTFF (EPO™ Enable 7 days/14 days)
- AlwaysLocate™^(note2) Intelligent Algorithm (Advance Power Periodic Mode) for power saving
- EASY™^(note2): Self-Generated Orbit Prediction for instant positioning fix
- GPS+GLONASS Consumption current(@3.3V):
 - Acquisition: 32mA Typical
 - Tracking: 26mA Typical
- High accuracy 1-PPS timing support for Timing Applications (± 20 ns jitter)
- High Update Rate: up to 10Hz^(note1)
- Logger function Embedded^(note2)
- Supports QZSS, SBAS(WAAS, EGNOS, GAGAN, MSAS) ranging
- Ultra-High Sensitivity: -165dBm

Note 1: SBAS can only be enabled when update rate is less than or equal to 5Hz.

Note2: Some features need special firmware or command programmed by customer.

1.3 System Block Diagram

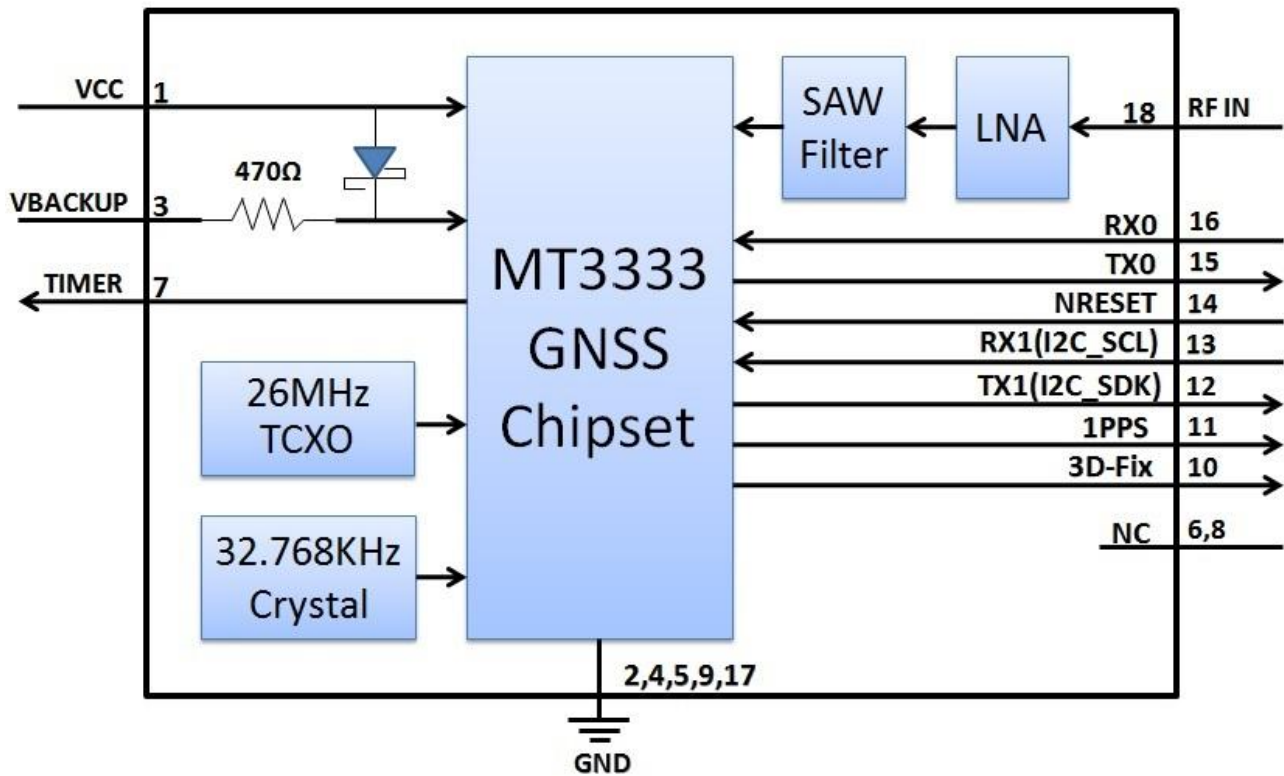

Figure 1-1: System Block Diagram.

1.4 Multi-tone active interference canceller

Because different application (Wi-Fi , GSM/GPRS,3G/4G,Bluetooth)are integrated into navigation system , the harmonic of RF signal will influence the GPS reception , The multi-tone active interference canceller (abbr: MTAIC) can reject external RF interference which come from other active components on the main board , to improve the capacity of GPS reception without any needed HW change in the design .CD-SA1209D can cancel up to 12 independent channel interference continuous wave (CW).

1.5 1PPS

A pulse per second (1 PPS) is an electrical signal which precisely indicates the start of a second with the accuracy of ±20ns RMS (Root Mean Square). The PPS signal is provided through a designated output pin for many external applications. The pulse is not only limited to being active every second but is also allowed to set up the required duration, frequency, and active high/low through a programmable user-defined setting.

1.6 AGPS Support for Fast TTFF (EPO™)

The AGPS (EPO™) supply the predicated Extended Prediction Orbit data to speed TTFF ,users can download the EPO data to GPS engine from the FTP server by internet or wireless network ,the GPS engine will use the EPO data to assist position calculation when the navigation information of satellites are not enough or weak signal zone .

1.7 AlwaysLocate™ (Advance Power Periodic Mode)

Embedded need to be executed fully all the time, the algorithm can be set by different necessary to decide the operation level of GPS function, reduce power consumption, it will suffer positing accuracy to get the target of power saving and extend the usage time of product.

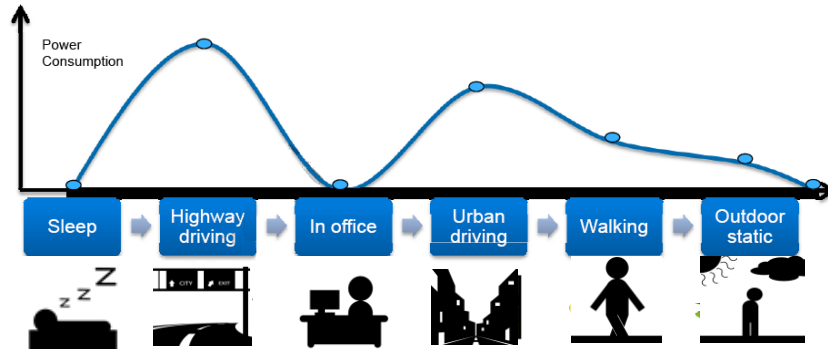

Figure 1-2: Always Locatie

1.8 EASY™

The EASY™ is embedded assist system for quick positioning, the GPS engine will calculate and predict automatically the single ephemeris (Max. up to 3 days)when power on, and save the predict information into the memory , GPS engine will use these information for positioning if no enough information from satellites, so the function will be helpful for positioning and TTFF improvement under indoor or urban condition, the Backup power (VBACKUP) is necessary.

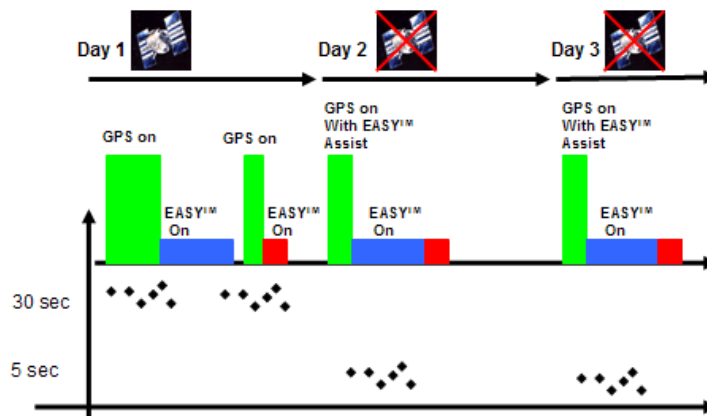

Figure 1-3 EASY System operation

Please refer to the Fig 1-3, When GPS device great the satellite information from GPS satellites, the GPS engine automatically pre-calculate the predict orbit information for 3 days.

The GPS device still can quickly do the positioning with EASY™ function under weak GPS signal.

1.9 Embedded Logger function(LOCUS)

The Embedded Logger function(LOCUS) don't need host CPU (MCU) and external flash to handle the operation , GPS Engine will use internal flash (embedded in GPS chipset) to log the GPS data (Data format : UTC, Latitude , longitude, Valid ,Checksum), the maximum log duration is up to two days under AlwaysLocate™.

2. Specification

2.1 Mechanical Dimension

Dimension: (Unit: mm, Tolerance: +/- 0.2mm)

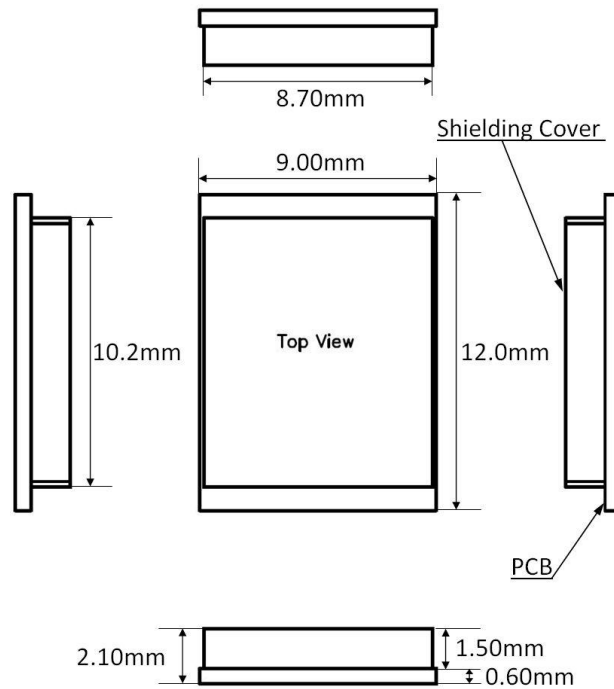

2.2 Recommended PCB pad Layout

(Unit: mm, Tolerance: 0.1mm)

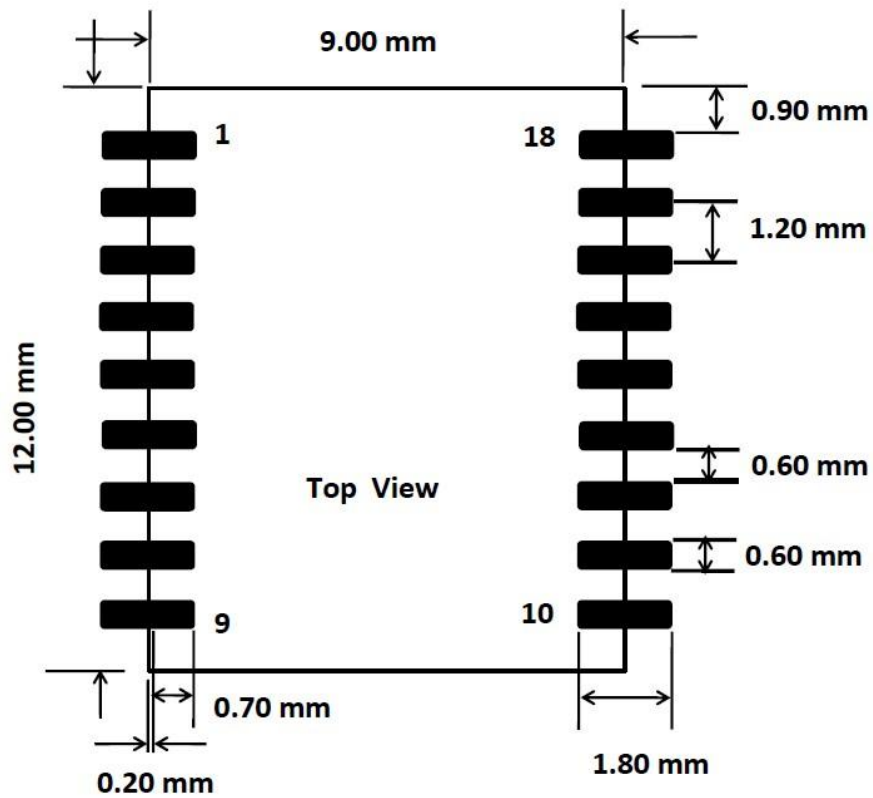

2.3 Pin Configuration

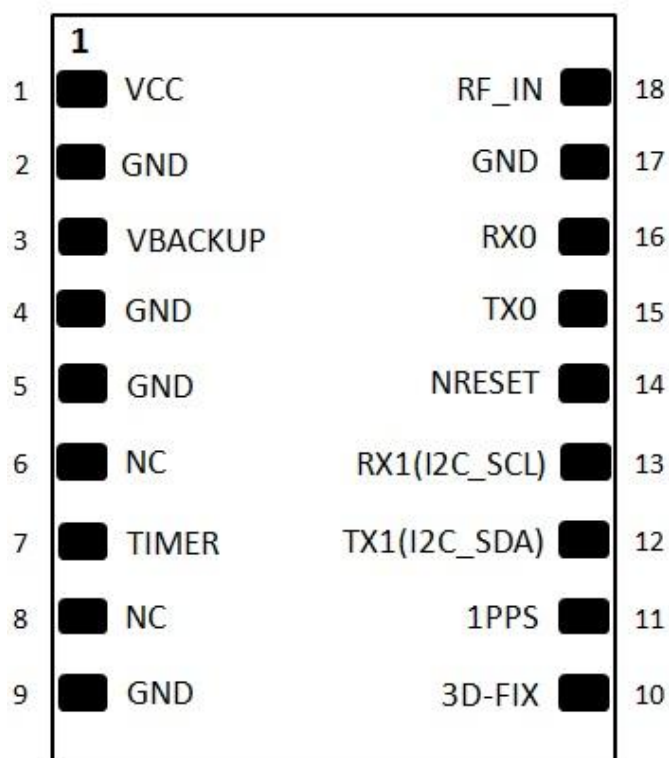

(Top view)

2.4 Pin Assignment

Pin	Name	I/O	Description & Note
1	VCC	PI	Main DC power input
2	GND	P	Ground
3	VBACKUP	PI	Backup power input for RTC & navigation data keep
4	GND	P	Ground
5	GND	P	Ground
6	NC	--	Not Connect
7	TIMER	O	The timer function support a time tick
8	NC	--	Not Connect
9	GND	P	Ground
10	3D_FIX	O	3D-Fix Indicator
11	1PPS	O	1PPS Time Mark Output 2.8V CMOS Level
12	TX1 / (I2C_SDA)	O	Serial Data Output / I2C Serial data(by custom firmware)
13	RX1 / (I2C_SCL)	I	Serial Data Input / I2C Serial clock(by custom firmware)
14	NRESET	I	Reset input, Low Active
15	TX0	O	Serial Data Output A for NMEA output (TTL)
16	RX0	I	Serial Data Input A for Firmware update (TTL)
17	GND	P	Ground
18	RF-IN	I	Antenna Signal Input

2.5 Description of I/O Pin

Pin1, VCC

The main DC power supply for the module. The voltage should be kept between from 3.0V to 4.3V. The ripple must be limited under 50mVpp (Typical: 3.3V).

Pin2, Pin4, Pin5, Pin9, Pin17, GND

Ground

Pin3, VBACKUP

This connects to the backup power of the GPS module. Power source (such as battery) connected to this pin will help the GPS chipset in keeping its internal RTC running when the main power source is removed. The voltage should be kept between 2.0V~4.3V, Typical 3.0V.

IF VBACKUP power was not reserved, the GPS module will perform a lengthy cold start every time it is powered-on because previous satellite information is not retained and needs to be re-transmitted.

If not used, keep floating.

Pin6, NC

This pin is not connected, keep floating.

Pin7, TIMER

The timer function support a time tick generation of 31.25ms resolution, the period of timer can be from 31.25ms to 524287 s, the pin outputs signal during the timer period and becomes a input pin after time out, the system can use the pin to connect an external LDO controller and pull high circuit to enable other device for specified operation (ex: wake up GSM/GPRS processor to transmit location data of asset during one period, then enter power saving mode after finish its job)

If not used, keep floating.

Pin8, NC

This pin is not connected, keep floating.

Pin10, 3D_FIX

The 3D_FIX is assigned as a fix flag output. The timing behavior of this pin can be configured by custom firmware for different applications (Example: waking up host MCU). If not used, keep floating.

- Before 2D Fix

The pin should continuously output one-second high-level with one-second low-level signal

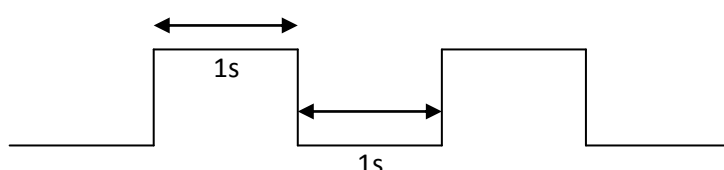

- After 2D or 3D Fix

The pin should continuously output low-level signal

Low 

Pin11, 1PPS

This pin provides one pulse-per-second output from the module and synchronizes to GPS time. If not used, keep floating.

Pin12, TX1 or I2C_SDA

This is the UART transmitter of the module. It is used for aiding. If not used, keep floating.

This pin can be modified to I2C_SDA through the customized firmware, it output the data for I2C application, if not used keep floating.

Pin13, RX1 or I2C_SCL

This is the UART receiver of the module. It is used for aiding. If not used, keep floating.

This pin can be modified to I2C_SCL through the customized firmware, it received the clock for I2C application, if not used keep floating.

Pin14, NRESET

Low active, it causes the module to reset. If not used, keep floating.

Pin15, TX0

This is the UART transmitter of the module. It outputs GPS information for application.

Pin16, RX0

This is the UART receiver of the module. It is used to receive commands from system.

Pin18, RF_IN

This is the GNSS RF signal input pin, which can be connected to a passive antenna or an active antenna.

(please refer to that page 19 & 20)

2.6 Specification List

Item	Description
GNSS Solution	MTK MT3333
Frequency	GPS L1, 1575.42MHz GLONASS L1, 1598.0625~1605.375MHz
Sensitivity(GPS portion)	Acquisition: -148dBm, cold start Reacquisition: -163dBm Hot start Tracking: -165dBm
SV Number	#1~32 for GPS #65~96 for GLONASS
TTF (No. of SVs>4, C/N>40dB, PDop<1.5)	Hot start: 1 second typical Warm start: 33 seconds typical Cold start: 35 seconds typical, 60 seconds Max
Update Rate	1Hz (default), maximum 10Hz
Baud Rate	9600 bps (default)
Position Accuracy	Without aid:3.0m (50% CEP) DGPS(SBAS(WAAS,EGNOS,MSAS)):2.5m (50% CEP)
Velocity Accuracy	Without aid : 0.1m/s DGPS(SBAS(WAAS,EGNOS,MSAS,GAGAN)):0.05m/s
Timing Accuracy(1PPS Output)	±20 ns RMS within 100ms in one pulse
Altitude	Maximum 18,000m (60,000 feet)
Velocity	Maximum 515m/s (1000 knots)
Acceleration	Maximum 4G
DGPS	SBAS(default) [WAAS, EGNOS, MSAS,GAGAN]
Power Supply	VCC : 3.0V to 4.3V ; VBACKUP : 2.0V to 4.3V
Current Consumption @ 3.3V,1Hz Update Rate	GPS+GLONASS 32mA acquisition, 26mA tracking
Backup Power Consumption@ 3V	15uA TYP.
Working Temperature	-40 °C to +85 °C
Dimension	12 x 9 x 2.1 mm, QFN
Weight	0.6g

2.7 Absolute Maximum Ratings

The voltage applied for VCC should not exceed 4.3VDC.

	Symbol	Min.	Typ.	Max.	Unit
Power Supply Voltage	VCC	3.0	3.3	4.3	V
Backup battery Voltage	VBACKUP	2.0	3.0	4.3	V

2.8 Operating Condition

	Condition	Min.	Typ.	Max.	Unit
Operation supply Ripple Voltage	—	—	—	50	mVpp
RX0 TTL H Level	—	2.0	—	VCC	V
RX0 TTL L Level	—	0	—	0.8	V
TX0 TTL H Level	—	2.4	—	2.8	V
TX0 TTL L Level	—	0	—	0.4	V

2.9 GPS/GLONASS External Antenna Specification(Recommended)

It is important that the antenna gets a clear view of the sky and is positioned on a surface level to the horizon for best results. The following specification has to meet for the use reference design.

Characteristic	Specification
Polarization	Right-hand circular polarized
Frequency Received	1.575GHz~1.615GHz
Power Supply	3.3V
DC Current	3mA < IDC < 30mA at 3.3V
Total Gain	+ 25dBi
Output VSWR	< 2.5
Impedance	50Ω
Noise Figure	< 1.5dB

3. Protocols

3.1 NMEA Output Sentences

Table-1 lists each of the NMEA output sentences specifically developed and defined by MTK for use within MTK products

Table-1: Each of the NMEA output sentences	
Option	Description
GGA	Time, position and fix type data.
GSA	GNSS receiver operating mode, active satellites used in the position solution and DOP values.
GSV	The number of GNSS satellites in view satellite ID numbers, elevation, azimuth, and SNR values.
RMC	Time, date, position, course and speed data. Recommended Minimum Navigation Information.
VTG	Course and speed information relative to the ground.

Table-2: NMEA Output Sentence for GPS and GNSS					
System	GGA	GSA	GSV	RMC	VTG
GPS	GPGGA	GPGSA	GPGSV	GPRMC	GPVTG
GNSS (GPS+GLONASS)	GNGGA	GPGSA GLGSA	GPGSV GLGSV	GNRMC	GNVTG
GNSS (GPS+GLONASS+Galileo)	GNGGA	GPGSA GLGSA GAGSA	GPGSV GLGSV GAGSV	GNRMC	GNVTG

Note: GP is a short term of “GPS”; GL is “GLONASS”; GA is “Galileo” and GN is “multi-system”
 Default setting for GPS+GLONASS output, the GPS + GLONASS + Galileo need custom firmware and suggest work baud rate is 115,200bps.

GGA—Global Positioning System Fixed Data. Time, Position and fix related data

Table-3 contains the values for the following example :

*\$GNGGA,165006.000,2241.9107,N,12017.2383,E,1,14,0.79,22.6,M,18.5,M,,*42*

Table-3: GGA Data Format			
Name	Example	Units	Description
Message ID	\$GNGGA		GGA protocol header
UTC Time	165006.000		hhmmss.sss
Latitude	2241.9107		ddmm.mmmm
N/S Indicator	N		N=north or S=south
Longitude	12017.2383		dddmm.mmmm
E/W Indicator	E		E=east or W=west
Position Fix Indicator	1		See Table-4
Satellites Used	14		Range 0 to 14
HDOP	0.79		Horizontal Dilution of Precision
MSL Altitude	22.6	meters	Antenna Altitude above/below mean-sea-level
Units	M	meters	Units of antenna altitude
Geoidal Separation	18.5	meters	
Units	M	meters	Units of geoids separation
Age of Diff. Corr.		second	Null fields when DGPS is not used
Checksum	*42		
<CR> <LF>			End of message termination

Table-4: Position Fix Indicator	
Value	Description
0	Fix not available
1	GPS fix
2	Differential GPS fix

Note: When inputting the command \$PMTK353,0,1,0,0,0*2A, \$GNGGA will change to \$GLGGA (For GLONASS).
 When inputting the command \$PMTK353,1,0,0,0,0*2A, \$GNGGA will change to \$GPGGA (For GPS)

GSA—GNSS DOP and Active Satellites

Table-5 contains the values for the following example :

\$GPGSA,A,3,17,19,11,30,01,28,08,22,07,,,,,1.31,0.79,1.04*03

\$GLGSA,A,3,75,70,76,85,87,,,,,,1.31,0.79,1.04*10

Table-5: GSA Data Format			
Name	Example	Units	Description
Message ID	\$GPGSA or \$GLGSA		GSA protocol header
Mode 1	A		See Table-6
Mode 2	3		See Table-7
Satellite Used	17		SV on Channel 1
Satellite Used	19		SV on Channel 2
....
Satellite Used			SV on Channel 12
PDOP	1.31		Position Dilution of Precision
HDOP	0.79		Horizontal Dilution of Precision
VDOP	1.04		Vertical Dilution of Precision
Checksum	*03		
<CR> <LF>			End of message termination

Table-6: Mode 1	
Value	Description
M	Manual—forced to operate in 2D or 3D mode
A	2D Automatic—allowed to automatically switch 2D/3D

Table-7: Mode 2	
Value	Description
1	Fix not available
2	2D (< 4 SVs used)
3	3D (\geq 4 SVs used)

GSV— Satellites in View, includes GPS(GPGSV),GLONASS(GLGSV) and Galileo(GAGSV)

Table-8 contains the values for the following example :

\$GPGSV,4,1,15,195,59,162,39,05,53,288,45,42,51,129,36,02,49,348,41*4E
 \$GPGSV,4,2,15,19,49,149,42,06,42,065,43,13,29,187,37,12,24,254,33*75
 \$GPGSV,4,3,15,17,23,149,50,09,14,041,32,25,09,294,37,30,08,119,36*7E
 \$GPGSV,4,4,15,07,05,090,29,193,,,40,194,,,38*45

Table-8: GPGSV Data Format			
Name	Example	Units	Description
Message ID	\$GPGSV		GSV protocol header
Number of Messages	4		Range 1 to 4 <i>(Depending on the number of satellites tracked, multiple messages of GSV data may be required.)</i>
Message Number1	1		Range 1 to 4
Satellites in View	15		
Satellite ID	195		Channel 1 (Range 1 to 32) Note: 193~ 195 for QZSS
Elevation	59	degrees	Channel 1 (Maximum 90)
Azimuth	162	degrees	Channel 1 (True, Range 0 to 359)
SNR (C/No)	39	dBHz	Range 0 to 99,(null when not tracking)
....
Satellite ID	07		Channel 4 (Range 1 to 32)
Elevation	05	degrees	Channel 4 (Maximum 90)
Azimuth	090	degrees	Channel 4 (True, Range 0 to 359)
SNR (C/No)	29	dBHz	Range 0 to 99, (null when not tracking)
Checksum	*4E		
<CR> <LF>			End of message termination

Table-9 contains the values for the following example :

\$GLGSV,3,1,10,76,74,276,33,75,43,170,32,86,39,359,21,87,33,283,42*6D

\$GLGSV,3,2,10,77,20,330,,71,15,103,,70,07,056,35,72,06,150,*65

\$GLGSV,3,3,10,85,05,043,32,88,01,249,*64

Table-9: GLGSV Data Format			
Name	Example	Units	Description
Message ID	\$GLGSV		GSV protocol header
Number of Messages	3		Range 1 to 4 (<i>Depending on the number of satellites tracked, multiple messages of GSV data may be required.</i>)
Message Number1	1		Range 1 to 4
Satellites in View	10		
Satellite ID	76		Channel 1 (Range 65 to 96)
Elevation	74	degrees	Channel 1 (Maximum 90)
Azimuth	276	degrees	Channel 1 (True, Range 0 to 359)
SNR (C/No)	33	dBHz	Range 0 to 99,(null when not tracking)
....
Satellite ID	88		Channel 4 (Range 1 to 32)
Elevation	01	degrees	Channel 4 (Maximum 90)
Azimuth	249	degrees	Channel 4 (True, Range 0 to 359)
SNR (C/No)		dBHz	Range 0 to 99,(null when not tracking)
Checksum	*6D		
<CR> <LF>			End of message termination

Table-10 contains the values for the following example :

\$GAGSV,2,1,06,04,79,161,42,12,59,058,38,11,38,332,35,19,36,042,32*6B

\$GAGSV,2,2,06,24,10,226,,25,06,272,*69

Table-10: GAGSV Data Format			
Name	Example	Units	Description
Message ID	\$GAGSV		GSV protocol header
Number of Messages	2		Range 1 to 4 (<i>Depending on the number of satellites tracked, multiple messages of GSV data may be required.</i>)
Message Number1	1		Range 1 to 4
Satellites in View	06		
Satellite ID	04		Channel 1 (Range 1 to 36)
Elevation	79	degrees	Channel 1 (Maximum 90)
Azimuth	161	degrees	Channel 1 (True, Range 0 to 359)
SNR (C/No)	42	dBHz	Range 0 to 99,(null when not tracking)
....
Satellite ID	25		Channel 4 (Range 1 to 36)
Elevation	06	degrees	Channel 4 (Maximum 90)
Azimuth	272	degrees	Channel 4 (True, Range 0 to 359)
SNR (C/No)		dBHz	Range 0 to 99,(null when not tracking)
Checksum	*6D		
<CR> <LF>			End of message termination

RMC—Recommended Minimum Navigation Information

Table-11 contains the values for the following example :

`$GNRMC,064951.000,A,2307.1256,N,12016.4438,E,0.03,165.48,260406,3.05,W,A*2C`

Table-11: RMC Data Format			
Name	Example	Units	Description
Message ID	\$GNRMC		RMC protocol header
UTC Time	064951.000		hhmmss.sss
Status	A		A=data valid or V=data not valid
Latitude	2307.1256		ddmm.mmmm
N/S Indicator	N		N=north or S=south
Longitude	12016.4438		dddmm.mmmm
E/W Indicator	E		E=east or W=west
Speed over Ground	0.03	knots	
Course over Ground	165.48	degrees	True
Date	260406		ddmmyy
Magnetic Variation	3.05, W	degrees	E=east or W=west
Mode	A		A= Autonomous mode D= Differential mode E= Estimated mode
Checksum	*2C		
<CR> <LF>			End of message termination

Note: when inputting the command `$PMTK353,0,1,0,0,0*2A` , \$GNRMC will change to \$GLRMC (for GLONASS).
When inputting the command `$PMTK353,1,0,0,0,0*2A` : \$GNRMC will change to \$GPRMC (for GPS).

VTG—Course and speed information relative to the ground

Table-12 contains the values for the following example:

\$GNVTG,352.70,T,,M,0.07,N,0.13,K,A*25

Table-12: VTG Data Format			
Name	Example	Units	Description
Message ID	\$GNVTG		VTG protocol header
Course	352.70	degrees	Measured heading
Reference	T		True
Course		degrees	Measured heading
Reference	M		Magnetic
Speed	0.07	knots	Measured horizontal speed
Units	N		Knots
Speed	0.13	km/hr	Measured horizontal speed
Units	K		Kilometers per hour
Mode	A		A= Autonomous mode D= Differential mode E= Estimated mode
Checksum	*25		
<CR> <LF>			End of message termination

Note: when inputting the command \$PMTK353,0,1,0,0,0*2A , \$GNVTG will change to \$GLVTG(For GLONASS). When inputting the command \$PMTK353,1,0,0,0,0*2A : \$GNVTG will change to \$GPVTG (For GPS).

3.2 MTK NMEA Command Protocols

Packet Type:

103 PMTK_CMD_COLD_START

Packet Meaning:

Cold Start : Don't use Time, Position, Almanacs and Ephemeris data at re-start.

Example:

\$PMTK103*30<CR><LF>

4. Reference Design

This chapter introduces the reference schematic design for the best performance. Additional tips and cautions on design are well documented on Application Note, which is available upon request.

4.1 Patch (Passive) Antenna

When using a passive antenna, please connect the antenna directly to Pin18, RF_IN.

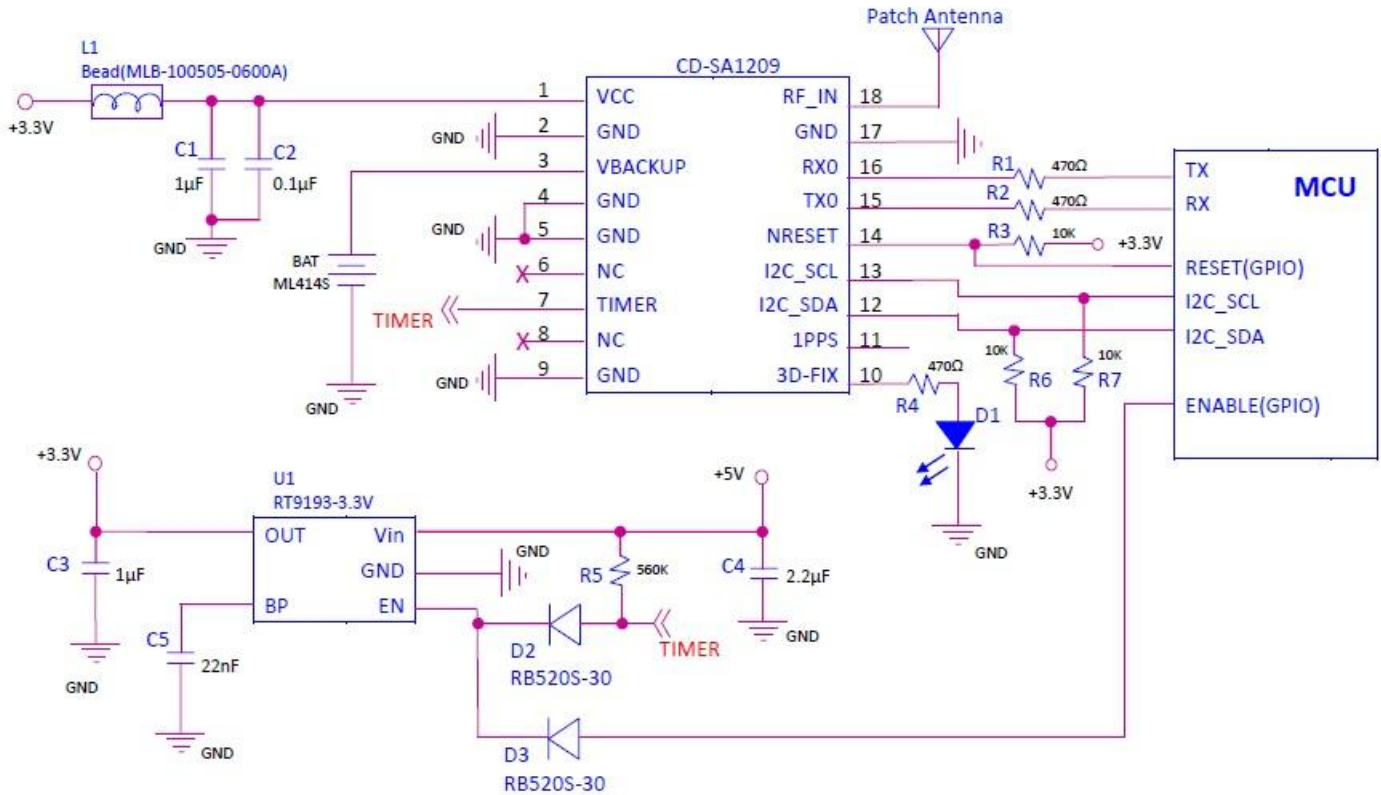

Note:

1. Ferrite bead L1 is added for power noise reduction.
2. C1 and C2 bypass capacitor should be put near the module.
For C3, the value chosen depends on the amount of system noise, the range from 1uF to 100uF is reasonable.
3. Damping resistors R1 and R2 could be modified based on system application for EMI.
4. Resistor R3 is added for Pull-up to VCC.

4.2 Active Antenna

When using an active antenna, please connect the antenna directly to Pin18, RF_IN.

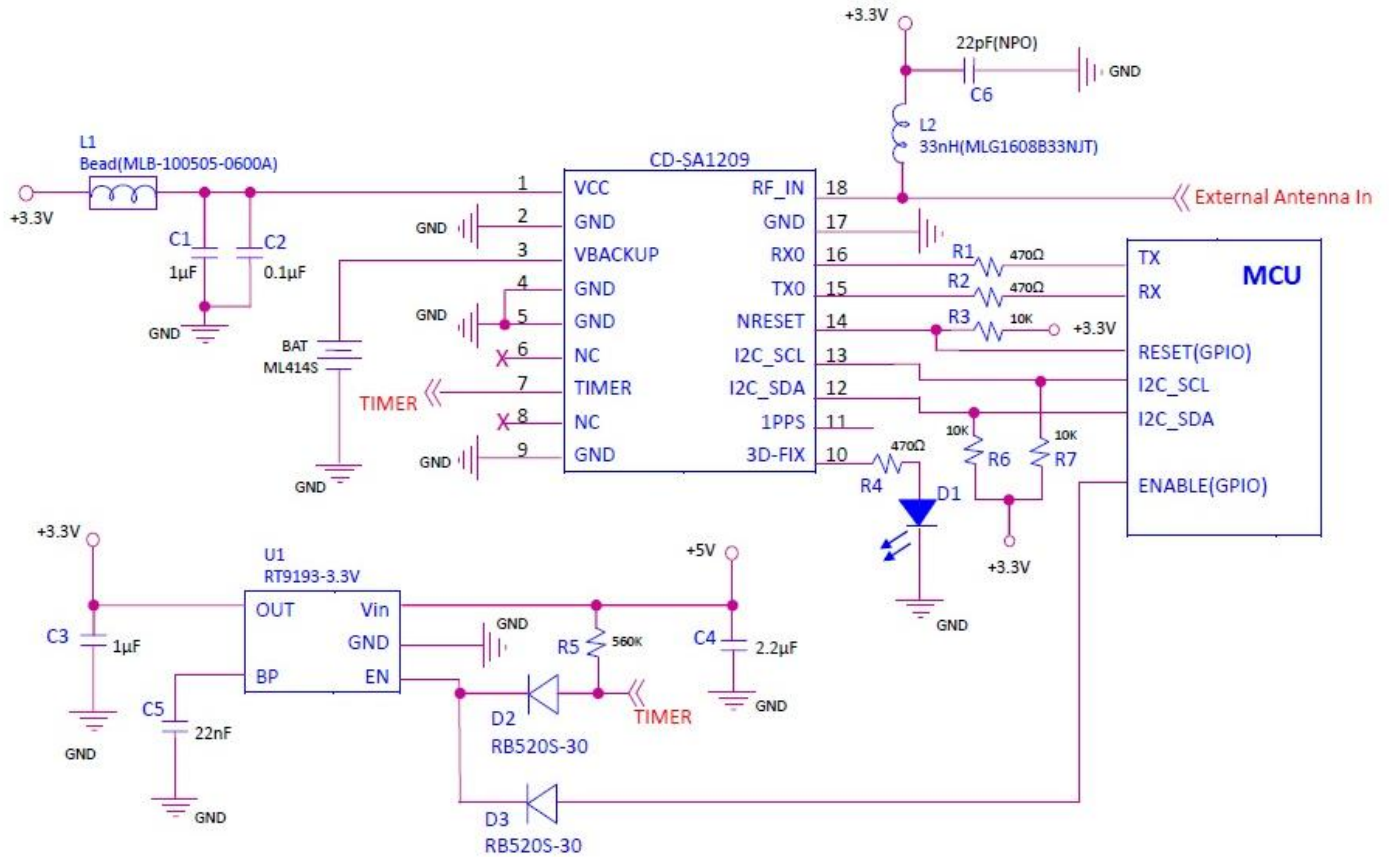

Note:

1. Ferrite bead L1 is added for power noise reduction.
2. C1 and C2 bypass capacitor should be put near the module.
3. For C3, the value chosen depends on the amount of system noise, the range from 1µF to 100µF is reasonable.
4. Damping resistors R1 and R2 could be modified based on system application for EMI.
5. Resistor R3 is added for Pull-up to VCC.
6. L2 choke inductor should be put near the Pin18 and C6 RF bypass capacitor should be put near the L2.

5. Tape Reel Packing Information

One Reel : 1,000pcs

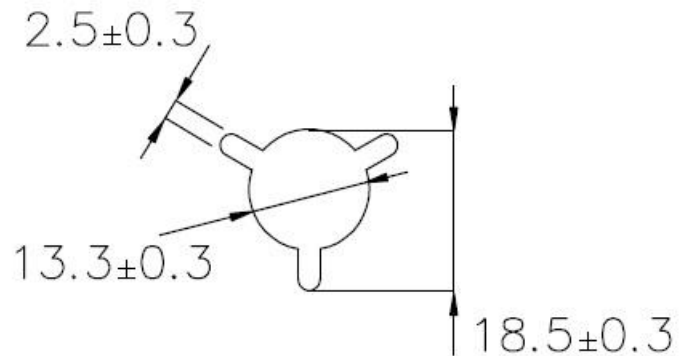
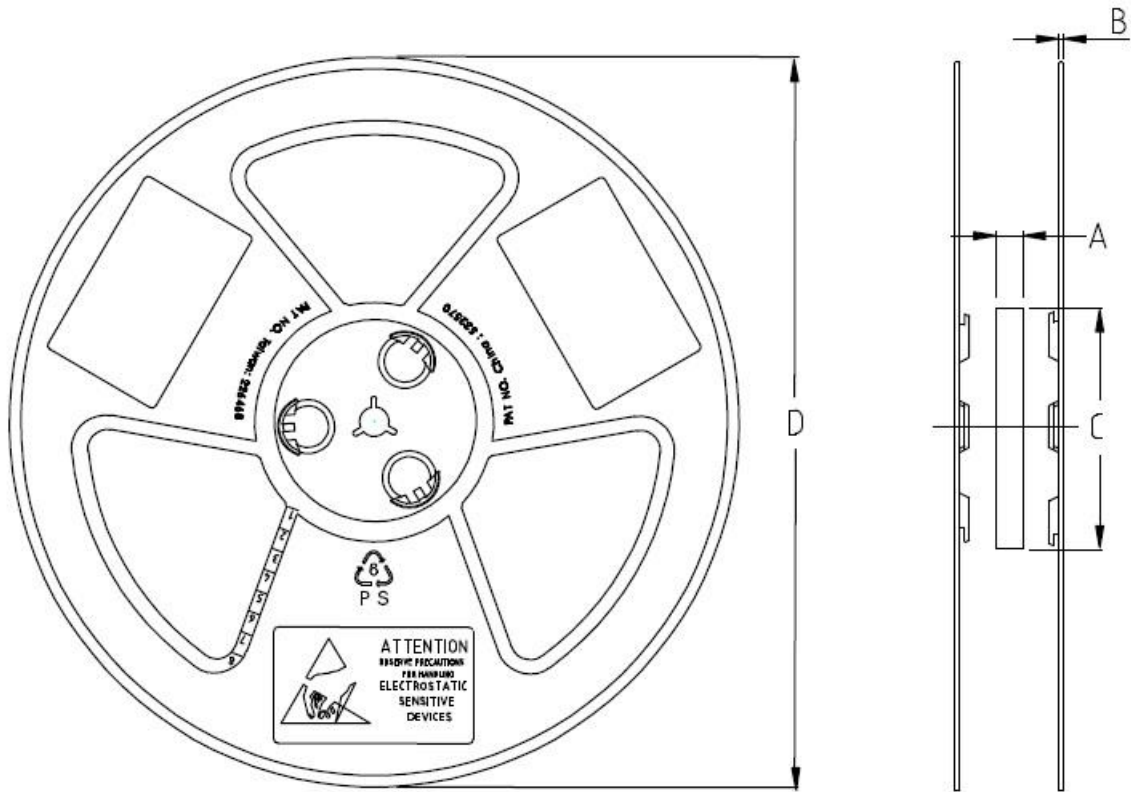

SPEC	13" REEL W: 24 mm				
	Material: HIPS				
ITEM	A	B	C	D	Surface Resistivity
DIM	$24.5 \pm \begin{matrix} +1.0 \\ -0.1 \end{matrix}$ mm	2.2 ± 0.2 mm	100 ± 1.0 mm	330 ± 1.5 mm	$< 10^{11} \Omega/\square$
ALTERNATE					

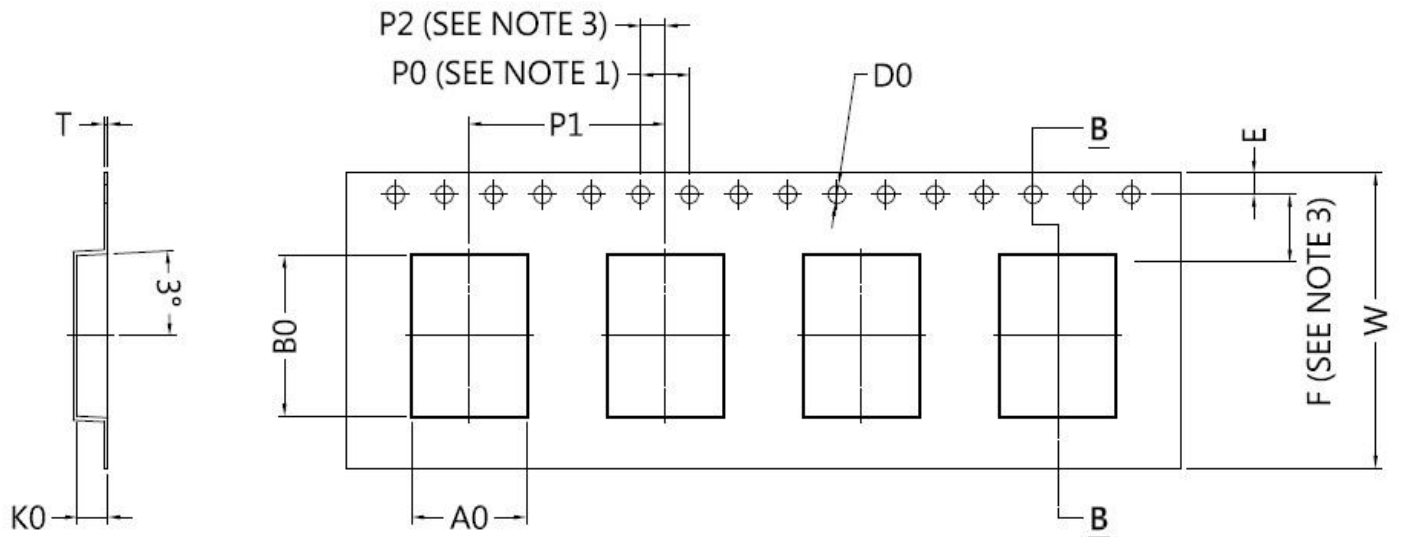

Item	Specification	Tol. (+/-)	Item	Specification	Tol. (+/-)
W	24.00	± 0.30	A0	9.33	± 0.10
E	1.75	± 0.10	B0	13.06	± 0.10
F	11.50	± 0.10	K0	2.50	± 0.10
D0	1.50	$+0.1/-0.0$	T	0.35	± 0.05
D1	—	—			
P0	4.00	± 0.10			
P1	16.00	± 0.10			
P2	2.00	± 0.10			

