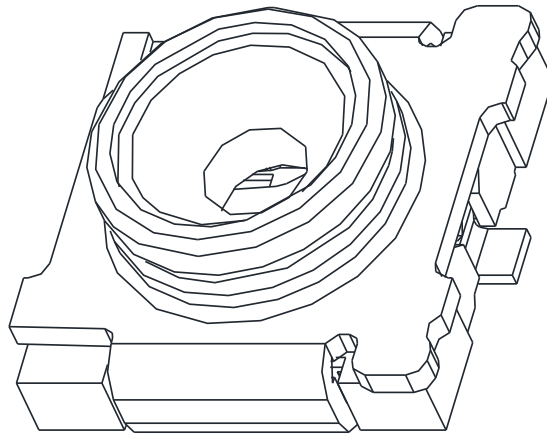


CONNTHERM

Document Number:

产品规格书  
Product Specification



P/N:

Title :

**Mini RF III Switch Connector**

Rev.	Release and Revision Description	<u>Prepared By/Date:</u>	<u>Approved By/Date:</u>
A	NEW RELEASE	Martin/03.07-17	ken/03.07-17

### Content

#### 目录

1. Scope/范围: .....	3
2. Product Application/产品应用: .....	3
3. Technology Parameters/技术参数 .....	3
4. Ratings/额定性能要求 .....	3
5. Profile Dimensions and material specifications /外形尺寸及材料规格 .....	4
6. Electrical Performance/电气性能 .....	4
7. Mechanical Performance/机械性能 .....	6
8. Environmental Performance/环境性能 .....	8
9. Recommended PCB Layout And Metal Mask 推荐的 PCB 安装焊盘及钢网规格 .....	10
10. Recommended Reflow Soldering Condition/SMT 推荐的回流焊接温度曲线图 .....	10
11. Test Sequence and Sample Quantity/测试顺序及样品数量 .....	11
12. Recommended Mating test Probe 推荐的测试探针 .....	12
13. Packaging 包装 .....	12
14. Usage Precaution 使用禁忌或注意事项 .....	13

### 1. Scope/范围:

This Product Specification covers the requirement of Mini RF VI Switch Connector on product performance, test methods and quality assurance provisions.

本规格书内容涵盖 Mini RF 第 3 代开关型同轴连接器产品的要求, 包括性能指标、测试方法及质量保证方面等。

### 2. Product Application/产品应用 :

The SMT type coaxial connector with switch is designed for Characteristic Measurement in the Mobile phones, W-LAN M, Microwave equipments, etc, application. Please let us know before using any of the products in the application not described above.

该SMT型同轴带开关连接器产品用于移动电话、W-LAN、其它无线和测量设备等领域电路的特性测量, 如果用于本文中未提及的领域请在使用前告知。

### 3. Technology Parameters/技术参数

3.1 Frequency Range(频率范围)	DC~11GHz
3.2 Nominal Characteristic Impedance (特性阻抗)	50 +/-5 Ohm
3.3 Power Rating (额定功率)	2W
3.4 V.S.W.R(电压驻波比)	1.2 Max.(DC~3GHz); 1.3 Max.(3~6GHz); 1.5 Max.(6~11GHz)
3.5 Insertion Loss(插入损耗)-NC State	-0.1dB Max.(DC~3GHz); -0.2dB Max.(3~6GHz); -0.5dB Max.(6~11GHz)
3.6 Isolation(隔离度)-NO State	-20dB Min.(DC~3GHz); -15dB Min.(3~6GHz); -10dB Min.(6~11GHz)
3.7 Operating Temperature Range (工作温度范围)	-40°C ~ +85°C
3.8 Operating Humidity (工作湿度)	95% R.H.MAX

### 4. Ratings/额定性能要求

4.1 Voltage Rating (额定电压)	60 VAC (R.M.S)
4.2 Initial Insulation Resistance (绝缘电阻)	500 M Ohm
4.3 Withstand Voltage (耐电压)	300V AC 1 Min.
4.4 Contact Resistance (接触电阻)	
4.4.1 Inner Contact (内导体) (扣除导体电阻) (Without conductor resistance)	70m ohm Max.
4.4.2 Outer Contact (外导体)	20 m ohm Max.
4.5 Durability(耐久性)	100 Cycles.

# CONNTERM

## Product Specification

P/N:

DOC. No.:

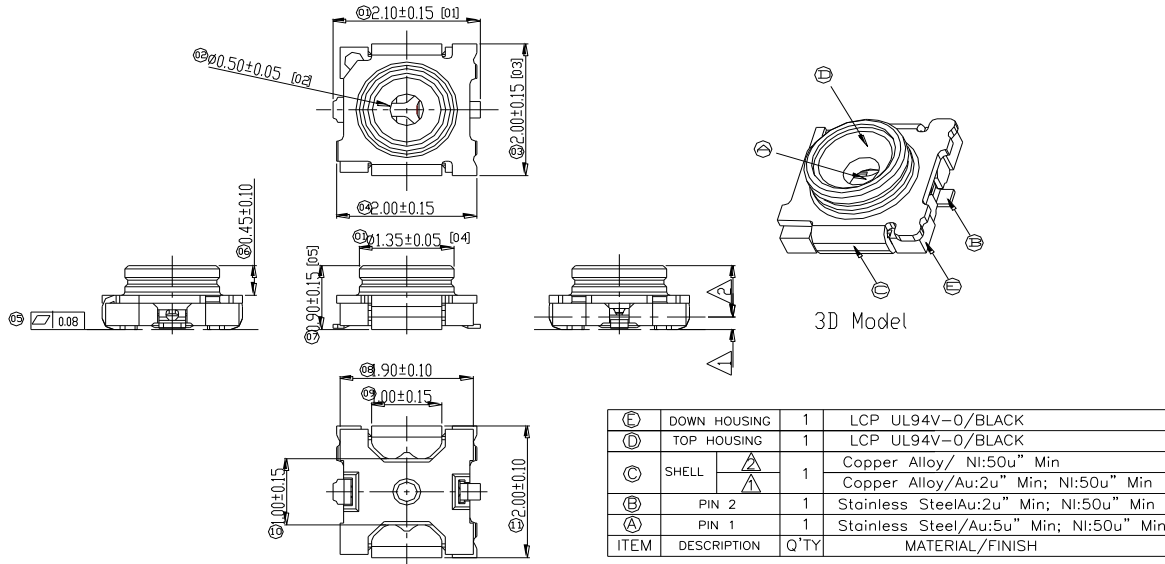
Rev.:

Page:

A

03.07-17

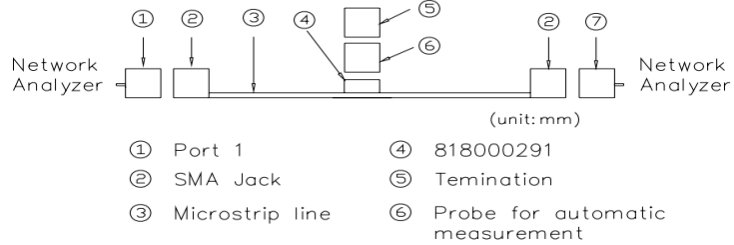
### 5. Profile Dimensions and material specifications /外形尺寸及材料规格



### 6. Electrical Performance/电气性能

Item 项目	Description 项目描述	Test Condition 测试条件	Requirement 规格要求
6.1	Contact Resistance 接触电阻	(EIA 364-23) Testing by the voltage dropping method with the low level current. 按照 EIA364-23 要求, 采用低电平压降方式测量电阻值。 Open circuit voltage 开路电压 : 20mV MAX Circuit current 电流 : 100mA MAX *Note: Test Methods are as following Figure1 and Figure 2, Body Resistance is eliminated here. 备注 : 测试方法参照图 1 和图 2, 此处的接触电阻测试不包括体电阻。	Inner contact 中心导体 : Initial 初始 70mΩ Max.* : After 测试后 100mΩ Max.* Ground contact 外导体 : Initial 初始 20mΩ Max.* : After 测试后 50mΩ Max.*
		Inner contact /中心导体: $R_{AB}$	Ground contact/外导体: $R_{CE} - R_{DE}$
		<p>Figure 1</p>	<p>Figure 2</p>

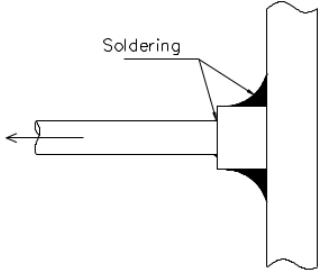




**Figure 4**

### 7. Mechanical Performance/机械性能

Item 项目	Description 项目描述	Test Condition 测试条件	Requirement 规格要求
7.1	Engage and Disengage Force 插拔力	<p>Measuring the required force for complete mated to the mated connector at 25±3mm/minutes.</p> <p>Measuring the required force for complete disengagement from the mated connector at 25±3mm/minutes.</p> <p>测试完全插配到位时的插入力, 并测试完全分离时的拔出力 ;</p> <p>插拔速率控制 : 25± 3 毫米/每分钟。</p>	<p>1.Mating Force (插入力) : 30N(3Kgf) Max</p> <p>2.Unmating Force (拔出力) : 5~30N (0.5~3Kgf)</p>
7.2	Allowed Push Force 推压力	<p>The connector is soldered on the test PCB and then push the switch of the connector from on-state to off-state by a test probe as shown in Figure 5 with the required force along the axis direction, which is needed to get 15dB isolation at 6GHz is measured.</p> <p>如图 5 所示, 通过测试探针以轴向力下压连接器开关的动弹片使开关完全断开, 当 6GHz 频点所 对应的隔离度达到 15dB 时, 测试所施加的力.</p>	<p>1.5~2.5N (0.15~0.25Kgf)</p>
7.3	Durability 耐久性	<p>Engage and disengage the receptacle connector which is soldered to the test board and its mating plug cable for 100 cycles at the speed of 25± 3mm/minutes along the mating direction by the push-push machine.</p> <p>将母座焊接在测试板上, 然后, 通过插拔力测试仪沿配合方向以每分钟 25± 3 毫米的速度插拔公母头 100 个循环进行测试。</p>	<p>Appearance: No abnormality 外观 : 无损伤</p> <p>Contact Resistance: Shall meet 6.1 接触电阻 : 满足节 6.1 要求</p>

7.4	<p>Adhered of Electrode Terminal 焊点保持力</p>	<p>Soldering test sample with test PCB . Measurement conditions are as followings according to figure 5: 将产品已正常焊接工艺焊在 PCB 上,按图 5 方式在下述条件下测量: 1. Force(拉力):F1=40N 2.Time(时间):5+/-1s.</p>	<p>No excoriation of electrode terminal 焊接端子无明显脱落</p>
			<p><b>Figure 5</b></p>
7.5	<p>Vibration 机械振动</p>	<p>Apply the following vibration conditions to the mating connector. During the testing,run 100mA DC to check electrical discontinuity. Frequency:10Hz → 100Hz → 10Hz/approx 20minutes. Half amplitude,Peak value of acceleration: 3mm or 60m/s<sup>2</sup> (6G). Directions,cycle:3 mutually perpendicular direction,3 cycles for each direction. 将公母头配合,并施加如下条件测试.在测试期间,施加 100mA DC 电压,并检验电不连续性.频率: 10Hz→100Hz→10Hz/20minutes. 半振幅、加速度: 3mm、60 m/s<sup>2</sup> (6G) 方向和循环次数: 每个互相垂直方向上进行 3 次测量。</p>	<p>Appearance: No abnormality 外观: 无损伤;</p> <p>Contact Res.: Shall meet 6.1 接触电阻: 满足节 6.1 的要求;</p> <p>No discontinuities of 10 μ s or longer. 电不连续性不超过 10 μ s。</p>
7.6	<p>Shock 机械冲击</p>	<p>EIA 364-27 Condition A The object of this test procedure is to detail a standard method to assess the ability of a connector to withstand specified severity of mechanical shock.Test Current:100mA. Peak value of acceleration:750m/s<sup>2</sup> (75G) Duration:6ms Wave form : half sinusoidal Directions,cycle : 6 mutually perpendicular direction, 3cycles about each direction 此测试程序的目的是要作一详细标准以评估连接器能承受特定严格机械冲击的能力。 振幅峰值, :750m/s<sup>2</sup> (75G)持续时间: 6 毫秒 波型: 半正弦波,方向和循环次数: 每 6 个相互垂直方向上各进次 3 次.通电 100mA 测试电不连续性.</p>	<p>Appearance: No abnormality 外观: 无损伤;</p> <p>Contact Res.: Shall meet 6.1 接触电阻: 满足节 6.1 的要求;</p> <p>No discontinuities of 10 μ s or longer. 电不连续性不超过 10 μ s。</p>

### 8. Environmental Performance/环境性能

Item 项目	Description 项目描述	Test Condition 测试条件	Requirement 规格要求
8.1	Humidity 恒温恒湿试验	<p>(MIL-STD-202, Method 103 Test Condition B )</p> <p>Test is done without mating adaptor ,apply the following environment to the mating connector. Temperature : 60°C. Humidity : 95%R.H. Duration: 96 hours(50hours*).</p> <p>Note: The condition is under the “*”value when test is done with adaptor. Measurements should be done within 2hours.</p> <p>在未用转接器插合状态下, 根据 MIL-STD-202 试验条件 B 中的第 103 方法,对已配合的连接 器施加下列条件测试。 温度: 60°C ; 湿度: 95%R.H ; 持续时间: 96 小时(50 小时*); 备注 : 1) 在有转接器插合状态下测试时间为 “ * ” 值。 2) 所有测量应在完成湿度试验 2 小时 内进行。</p>	<p>Appearance: No abnormality 外观 : 无损伤 ;</p> <p>Contact Resistance: shall meet 6.1 接触电阻 : 满足 6.1 ;</p> <p>Insulation Resistance: shall meet 6.2 绝缘电阻 : 满足 6.2 ; Dielectric withstanding voltage shall meet 6.3 耐电压 : 满足 6.3</p>
8.2	Thermal Shock 冷热冲击	<p>(MIL-STD-202, Method 107 Test Condition )</p> <p>Apply the following environment to the mating connector as following: -50°C (30min)~25°C (5max) ~ 90°C (30min) ~ 25°C (5max) Transition time: : 5min. MAX Cycles: 50 Cycles</p> <p>根据 MIL-STD-202, 按如下试验条件对已配合 的连接 器施加下列条件测试。 循环 : -50°C (30min)~25°C (5max)~90°C (30min) ~ 25°C (5max) 转换时间: 5 min Max. 循环次数: 50 次数</p>	<p>Appearance: No abnormality 外观 : 无损伤 ;</p> <p>Contact Resistance: shall meet 6.1. 接触电阻 : 满足节 6.1 中的要求 ;</p> <p>Insulation Resistance: shall meet 6.2 绝缘电阻 : 满足节 6.2 中的要求 ;</p> <p>Dielectric withstanding voltageshall meet 6.3. 耐电压 : 满足节 6.3 中的要求。</p>



# CONN THERM

## Product Specification

P/N:

DOC. No.:

Rev.:

Page:

A

03.07-17

8.3

Solderability  
可焊性

Apply the following environment to the mating connector  
Temperature :  $245 \pm 5^{\circ}\text{C}$   
Duration : 3~5 second  
Test sample should be observed by the magnification of 10times after the test.  
按下列条件对已配合的连接器进行测试。  
温度:  $245 \pm 5^{\circ}\text{C}$   
持续时间: 3~5 秒钟. 观测 : 10 倍放大镜

At least 95% covered by a continuous new solder coating.  
吃锡面积大于 95%以上。

8.4

Resistance to soldering heat  
耐焊接热

According to the following conditions to test connector.  
1. Infrared reflow soldering, the peak temperature of 260 degrees Celsius, reference temperature curve, and the requirements of the SMT2 time;  
2. electric soldering iron, requires 300 degrees 5 seconds, 350 degrees below 3 seconds.  
按下列条件进行测试：  
1.红外线回流焊接，峰值温度260度以下，可参考温度曲线图，且要求SMT2次；  
2.电烙铁焊接，要求300度5秒，350度3秒以下。

Appearance:  
No abnormality.  
外观无明显损伤；  
Coplanarity of the solder tail should be not beyond 0.10mm  
焊脚平面度不超 0.10mm。

8.5

Salt Spray  
盐雾测试

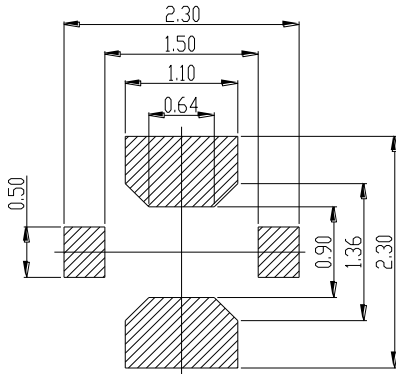
(EIA 364-26 Test Condition A)  
Apply the following environment to the mating connector  
Temperature :  $35 \pm 2^{\circ}\text{C}$   
Relative Humidity : 90~98%R.H  
Salt water density:  $5 \pm 1\%$   
Duration : 48 hours for contact area  
根据 EIA364-26 试验条件 A 中的要求,,对已配合的连接器施加下列条件测试：  
温度:  $35 \pm 2^{\circ}\text{C}$  ;  
相对湿度: 90~98%R.H ;  
盐水浓度:  $5 \pm 1\%$  ;  
持续时间: 48 hours ; (端子接触区)

Appearance:  
No abnormality  
外观 : 无损伤 ;

Contact Resistance:  
Shall meet 6.1  
接触电阻：  
满足节 6.1 中的要求

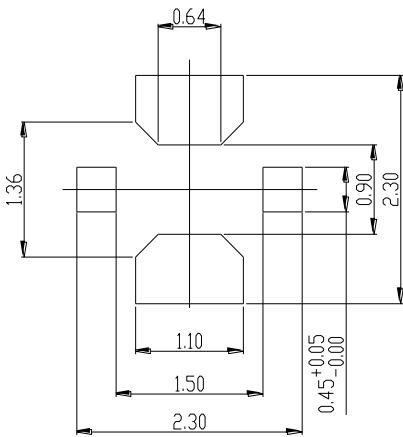
### 9. Recommended PCB Layout And Metal Mask 推荐的 PCB 安装焊盘及钢网规格

#### 9.1 Recommended PCB Layout 推荐的 PCB 安装焊盘 :

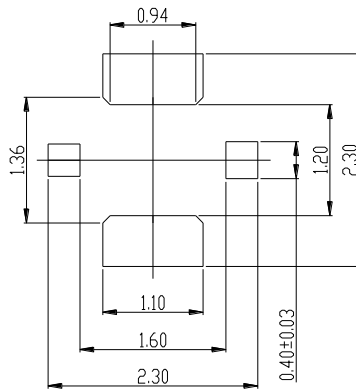


RECOMMENDED PCB LAYOUT  
TOLERANCE  $\pm 0.05\text{MM}$

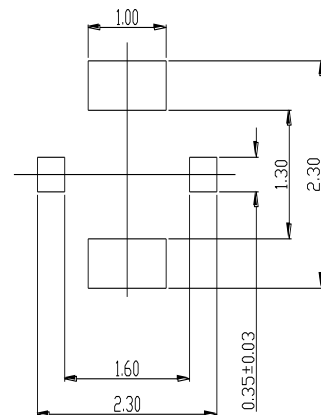
#### 9.2 Recommended Metal Mask 推荐的钢网规格



RECOMMEND METAL MASK  
(Thickness:0.08mm)



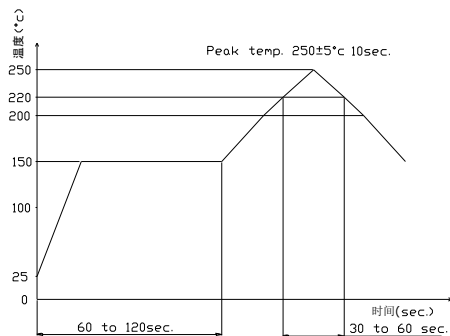
RECOMMEND METAL MASK  
(Thickness:0.10mm)



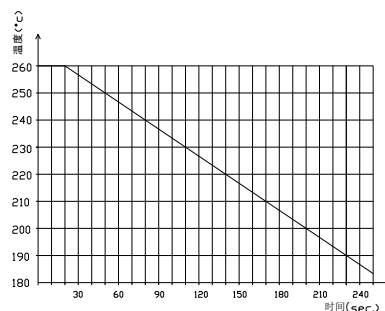
RECOMMEND METAL MASK  
(Thickness:0.12mm)

### 10. Recommended Reflow Soldering Condition/SMT 推荐的回流焊接温度曲线图

#### 11. 1 Recommended Temp. & Time of Reflow Soldering 建议回流焊温度与时间条件



#### 11. 2 Reflow Soldering Standard Condition 回流焊极限温度与时间条件



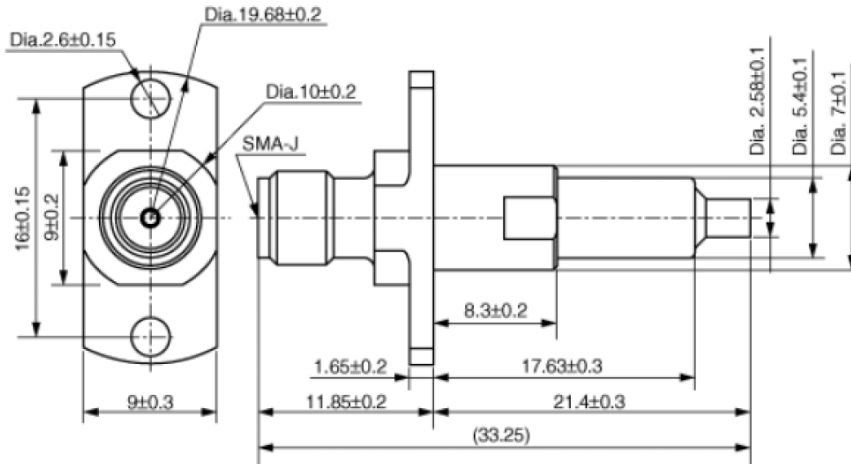
### 11. Test Sequence and Sample Quantity/测试顺序及样品数量

Test Item (测试项目)	Group (测试分组)											
	A	B	C	D	E	F	G	H	I	J	K	L
Examination of product (外观检测)	1,1 1	1,	1,3	1,	1,	1,6	1,	1,3	1,3	1,5		
Contact Resistance (接触电阻)	2,1 2			2,4	2,4	2,7	2,7			2,4		
Insulation Resistance (绝缘电阻)	3,					3,8	3,8					
Dielectric Withstanding Voltage (耐电压)	4,					4,9	4,9					
V.S.W.R (电压驻波比)	5,1 3											
Insertion Loss (插入损耗)	6,1 4											
Isolation (隔离度)	7,1 5											
Mating/un-mating Force (插拔力)	8,1 0											
Allowed Push Force (接触压力)		2,4										
Durability (机械寿命)	9,	3,										
Adhered of Electrode Terminal (焊点粘接力)			2,									
Vibration (振动)				3,								
Shock (冲击)					3,							
Humidity (湿度试验)						5,						
Thermal Shock (冷热冲击)							5,					
Solder ability (可焊性)								2,				
Resistance to soldering heat (耐焊接热试验)									2,			
Salt Spray (盐雾测试)										3,		
Sample QTY(PCS) 样品数量	5	5	5	5	5	5	5	5	5	5	5	5

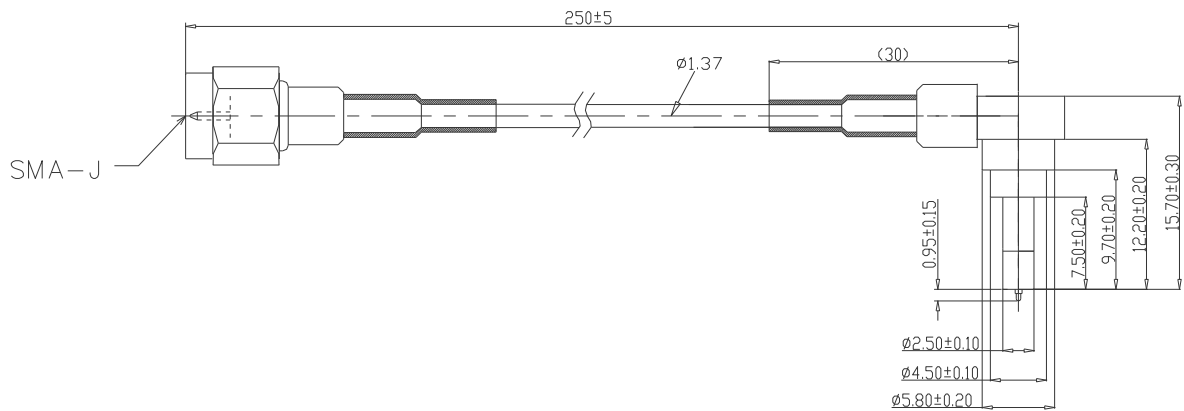
The number of group is test sequence 测试分组中的序号为试验顺序。

### 12. Recommended Mating test Probe 推荐的测试探针

#### Type A:



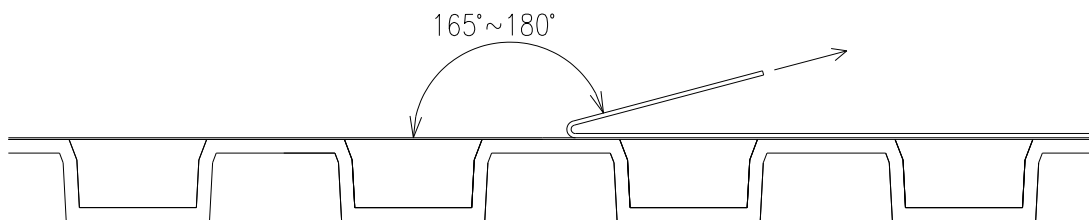
#### Type B:



### 13. Packaging 包装

13.1 The pull force of the tape: Pull the tape at the speed of 300mm/min, the pull force is 1.3N Max..

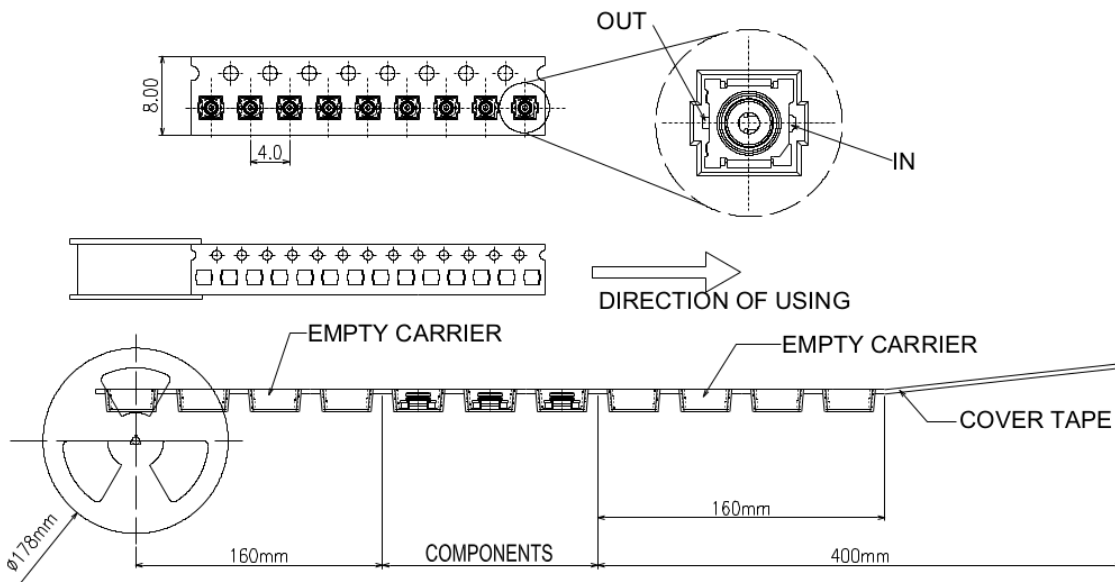
上带的剥离力度：300mm/min 的速度进行剥离，力度最大应该是 1.3N.



P/N:	DOC. No.:	Rev.:	Page:
		A	03.07-17

13.2 Packaging type: Tape&Reel,3000Pcs/R (Φ178mm) .

包装方式：载带包装，3000Pcs/卷（Φ178mm）。



### 14. Usage Precaution 使用禁忌或注意事项

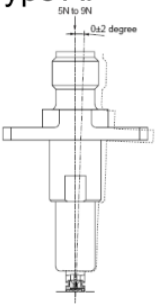
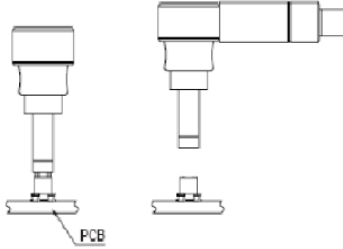
No	Items 项目	Matter 事项
14.1	Connection/ disconnection of connectors 连接器的连接 和断开	<p>a).To mate the connectors, the mating axis of both connectors must be aligned and the connectors can be mated fully, until they can't be moved. Not allowed in a very tilt mating angle and do not bend coaxial cable in the measuring procedure, otherwise you'll get a not good test data.</p> <p>b).To disconnect connectors, please disengage them along the axis direction of mating hole, until they're separated completely. With the point of insertion of allowed and when force is applied as shown in Figure 6</p> <p>a).公母头连接器进行配合前，务必确保两者对齐，对插到死点位置为止，表示两者已完全配合在一起，不要以极偏的角度插配连接器，测试使用过程中，请不要将同轴线折弯，否则可能会影响测试效果。</p> <p>b) 断开时请尽量沿配合开口的轴向方向竖直拔起线端公头直至两者完全脱离为止,对插时允许的配合角度和施加力如图 6 所示。</p> <p>Type A:    (n mm)</p> <p>Type B:    PCB</p>

Figure 6

No	Items 项目	Matter 事项
14.2	Precautions 禁忌	<p>a) Please mount this product at the position so that stress by wrap and/or bend of the PCB may not apply to it.                      b) Please avoid the cleaning of this product                      c) The product can't be in the longtime compression and the pressure on surface no more than 2Kgf. Please refer to figure 8</p> <p>a) 产品安装位置处不应有 PCB 翘曲和/或弯曲施加应力。                      b) 请避免清洁此产品                      c) 产品表面所承受压力最大不能超过 2 Kgf, 且不能处于长久受压状态. 请参照图 8 所示。</p> <div data-bbox="798 772 1173 1008" style="text-align: center;"> <p>压力 5kgf Max</p> <p>A 面</p> <p>B 面</p> <p>PCB</p> </div> <p style="text-align: center;"><b>Figure 8</b></p>
14.3	Stockpile condition 存储条件	<p>Use this product within 6 months after receipt                      Condition : Temp: -10~+40°C Humidity: 15~85%</p> <p>有效期：请在产品接收后的 6 个月内使用                      存储环境：温度：-10~+40°C； 湿度：15%~85%</p>